

# Tarantin

INDUSTRIES, INC.



Go to [www.Tarantin.com](http://www.Tarantin.com) to  
Order Online & Catalog Updates  
**1.800.922.0724**



# Table of Contents

Regulators.....	1-16, 85, 199-200, 210, 211
Valves.....	17 - 58
Repair Parts.....	59 - 66
Tanks.....	67 - 90
Signs & Decals.....	91 - 95
Pumps, Motors, & Bypass Valves.....	96 - 115
Plant Equipment.....	116 - 119
Compressors & Meters.....	120 - 129
Pump Stations & Dispensers.....	130 - 136
Vaporizers.....	137 - 139
Washers & O-Rings.....	140
Service Equipment.....	141 - 160
Hose Reels.....	161 - 165
Pipe & Fittings.....	166 - 192
Hose & Hose Fittings.....	193 - 198
Retail Accessories.....	199 - 202
Gauges.....	203 - 208
Outdoor Products.....	209 - 212
Quick Reference Guide.....	213 - 222
Grills.....	See Patio & Outdoor Living Catalog
Heaters.....	See Heater Catalog



## Other Useful Information:

Regulator Selection.....	16
Propane Tank Conversion Charts.....	67
Using a Portable Compressor.....	121
Pump Station Design Info.....	130
Anatomy of a Hannay Hose Reel.....	161
Line Sizing for Plastic Pipe.....	178
Line Sizing for Tracpipe.....	191
Meter Conversion.....	192
Anode Testing Procedure.....	192



I'm Technician Tom. Look for me throughout this catalog for helpful hints to guide you.

## PRODUCTS

### A

**Aboveground Tanks**...88

#### Accessories

Camping.....201, 210,  
211, 212

Dust Caps .....20

Forklift.....75, 77

Fusion .....185

Motor Fuel Tank.....82

Multivalve.....21-24

Paint.....157

Relief Caps..19, 21,23

RV Tank.....83-85

Tanks .....70,79

**Actuator for ESV**.....55

**Actuator for Internal  
Valve**.....51, 52, 54

#### Adapters

ACME.....39-41

Camping.....211, 212

Cap.....42

Chek-Lok.....36-37

Filling for Quick

Disconnect...135, 212

Fittings.....202, 212

Hose.....202, 212

Hose End Valve 39, 40

Inverted Flare.13, 200

Neptune - Veeder

Root.....127

POL.....13, 14, 43, 47,  
174, 202-210

Press Check.....149

Press Lock.....149

Pressure Gauge  
.....149, 203

QCC Type 1..135, 212

QCC Type 1 Filling  
.....136,212

Quick Disconnect  
.....135, 198, 212

Tees .....202, 210

Test.....148

Unloading.....37

**AG / UG Tanks**.....88

**Air Scribe** .....165

**Aluminum Tubing**...176

**Anchoring Kit**.....86

**Angle Valves**

Bulk Storage .....31

Liquid Transfer.....36

**Anode Monitoring**

Station .....90

**Anode Splice** .....90

**Anode Test Kit**..90, 153

**Anodes, Magnesium** 90

**Appliance Connectors** ....  
197-198

**Appliance Valves** .....32

**ASME Tanks** .....79-81

83, 87-88

**Assembly, High**

Pressure Test .....149

**Auto Stop Valve for**

Motor Fuel Tanks ..82

**Automatic Changeover**

Regulator.....5, 199

### B

**Back Check Valves**

Flanged .....49

Pressure.....49

Sight Flow .....50, 115

Swing-Away .....49

**Ball Valves**

Appliance .....32

Bronze, Union &

Counterstrike .....189

Flanged.....33-34

Threaded.....33

**Bee-Bopper** .....155

**Bender, Lever & Spring**

146

**Bleeder Valves**.....57

**Block, Test** .....149

**Blocks, Chock**.....143

**Bonnet Seal**.....173

**Brackets**

Forklift.....77

Meter .....129

Motor Fuel Tank.....82

Plastic Pipe .....187

Regulator .....15, 200

**Brass Hammer** .....144

**Breakaway Locks** ....70,  
129

**Breakaway Valve**  
.....56, 118, 130

**Broaches** .....145

**Brushes, Paint**.....157

**Bucket Bonnet** .....157

**Bulk Storage Gauge**207

**Burners, Weed** .....209

**Butt Fusion Fittings** 183

**Bypass Valves** 113, 130

### C

**Cabinets**

Motor Fuel .....76

Pump Station .....134

**Cables, Remote**

Control.....54

**Camping, Accessories**

.....201, 202, 210-212

**Caps**

ACME .....42

Breakaway Locks ..70,  
129

Cylinder.....70

Flare .....172, 174

POL.....174, 202

QCC Type 1

.....20, 42, 135

Weather .....30, 119

**Carrier, Tank**.....141

**Cart, Cylinder**.....142

**Cathodic Protection**..90

**Centrifuge Tube**.....153

**Chains for Hose Reels** .  
163

**Chamfering Tool** ...185,  
187

**Chek-Lok** .....36-37

**Chock Blocks**.....143

**Coated Copper Tubing**  
.....175

**Collars, Cylinder**.....70

**Commercial Equipment  
Connector** .....198

**Compressors**

Plant.....120

Portable for Pump

Outs .....121

**Connectors**

Appliance .....197

Commercial

Equipment.....198

Flexible.....197

Flexible - Stainless

Steel Braid .....116

Forklift.....18, 43, 75

Hose End Filler Valve

Coupling.....40

Hose End Filler Valve

Extension.....40

Hose End for DOT

Filling .....43

QCC Type 1 Filling135

Quick.....212

**Copper Seal**.....173

**Copper Stopper** .....176

**Copper Tubing**.....176

**Counterstrike**.....190

**Couplings**

Hose.....195

Motor Fuel Hose ..195

Quick Disconnect

.....135, 198, 212

**PRODUCTS**

<b>Covers, Regulator</b> ... 15, 200	2 PSIG Label..... 91	<b>Electrofusion System</b> .....177	Butt Fusion..... 183
<b>Crimping Tools, Hose</b> .. 194	Custom Decals..... 92	<b>Electrode Extension</b> . 90	Camping .....
<b>Counterstrike Fittings</b>	Cylinder Decals .91-93	<b>Emergency Response Kit</b> ..... 156	.....201, 202, 211, 212
<b>Steel Tubing</b>	<b>Decals continued</b>	<b>Emergency Shutoffs</b>	Counterstrike 189-190
Ball Valve ..... 189	Piping Decals ..... 91	Actuator ..... 55	Flare... 5, 13, 173-174
Counterstrike ..... 190	Placards .....93-95	Accessories..... 55	Forged Steel..166-167
Cutters ..... 189	Retest Decals ..... 95	Bulk Plants..... 55	alvanized.....169, 171
Fittings..... 188-189	Warning Labels .91-95	<b>Emergency Shutoffs cont.</b>	Hose Barb .....193-194
Gas Piping ....188-189	<b>Detectors</b>	Railroad Car ..... 55	Mechanical..... 181
Manifold..... 189	CO & Gas ..... 150	<b>Excess Flow Valves</b>	Pipe.....166, 167, 171
Striker Plates ..... 189	Combustible Gas.. 152	Container Service... 45	POL..... 202
<b>Curb Box</b> ..... 186	Leak ..... 154	DOT Cylinders..... 46	Purging ..... 135
<b>Custom Decals</b> ..... 92	<b>Dial Replacement</b>	Flange Mounted ..... 46	Reducing..... 166, 172
<b>Cutters</b>	ASME Tank Gauge	Liquid or Vapor.....14, 45-47	<b>Schedule 40</b> .... 169,171
Tubing..... 146	Dials.....87-89,206	POL Adapters.. 14, 47, 202	Schedule 80 ..166-167
Counterstrike ..... 189	Forklift..... 77	Pressure Gauge ..... 46	Socket Weld..... 167
Plastic Pipe ..... 187	Replacement ..... 205	<b>Extend-A Stay</b> ... 85, 201	Socket Fusion ..... 184
<b>Cylinders</b>	RV Tank ..... 85	<b>Extend-A-Flow</b> .. 85, 201	<b>Fixed Liquid Level</b>
Accessories..... 70, 79	<b>Dispensers</b>	<b>Extend-A-Match</b> ..... 144	Gauge.....57, 75
Aluminum .....72-73	<b>Pump Station</b> 130,134	<b>Extinguishers, Fire</b> 158	<b>Flange, Insulation Sets</b>
Decals .....91-93, 95	<b>Distribution Post</b> .... 210	<b>F</b>	170
DOT 68-69, 71-72, 75, 78	<b>DOT Cylinders</b> ..... 68-69, 71-72, 74, 78	<b>Ferrules, Hose Barb</b> ..... 193-194	<b>Flanges, Forged Steel</b> . 170
Horizontal DOT..71-72	<b>Drill Kits</b> ..... 147	<b>Filler Valves</b>	<b>Flare</b>
Mowers.....71,72	<b>Drip Legs</b> ..... 172	Double Check....47-48	Caps..... 172, 174
<b>Cylinder Filling, Hydraulic with Auto Shut Off</b> .57	Dust Caps	Forklift..... 75	Filter..... 172
<b>Cylinder Valves</b>	ACME ..... 42	Motor Fuel Tank..... 82	Fittings, Brass .....
Compact, OPD ..... 20	Cylinder Valve ...21-23	RV Tank ..... 85	.....173-174
Liquid Withdrawal..... 17-19, 21	Filler Valve ..42, 47-48	Single Check ..... 48	J Clips..... 175
RV & Small ASME ..... 17-19, 20	Multiport .....29-30	<b>Filter, Flare</b> ..... 172	Plugs..... 172, 174
Vapor .....17-19	OPD Valve ..... 20	<b>Fire Extinguishers</b> .. 158	<b>Flare Tower</b> ..... 151
<b>Cylinder Vise</b> ..... 160	QCC Type 1 & 2 ..... 20,42, 135	<b>First Aid Kit</b> ..... 156	<b>Flaring Tools</b> ..... 146
<b>Cylinder Wrench</b> .... 160	Relief Valve .25-27, 30	<b>Fittings</b>	<b>Flashlight</b> ..... 151
<b>D</b>	<b>Dump Valve, 3 way for ESV</b> ..... 56, 119	Adapter ...13, 14, 202, 212	<b>Flexible Connectors</b> .....
<b>Decals</b>	<b>E</b>	Black Iron..... 169, 171	Appliance.....197
	<b>Electric Fusion Tool</b> 185		Plant.....197
	<b>Electrical Parts for Reels</b> ..... 163		<b>Flexible Risers</b> ..... 182

## PRODUCTS

**Float Gauges,  
Tank & Cylinder** .....  
87-89, 206  
**Flomatic Valve** ..... 53  
**Flow Indicator** .. 50, 116  
**Forged Steel Fittings** ....  
166-168  
**Forklift Cylinder**  
Aluminum..... 73  
Steel..... 74  
**Free-All** ..... 154  
**Freeze Valve** ..... 153  
**Fusion Accessories** 185  
**Fusion Tool** ..... 185

## G

**Gas Detector,  
Residential** ..... 150  
**Gas Match, Lighters**  
..... 144, 209  
**Gas Outlet Box** ..... 198  
**GasBreaker**..... 190  
**Gasoil** ..... 154  
**Gaskets, Flexitallic** 170  
**Gauges**  
Bulk Storage ..... 208  
Cylinder and Tank  
..... 87-89  
Forklift Cylinder..... 77  
Magnetel ..... 207  
Pressure..... 203  
Replacement Dials  
.. 88-89, 205-206, 207  
Replacement Float  
..... 87-89, 208  
Roto Gauge..... 208  
Rough Rider..... 207  
Truck..... 207-208  
**Gauging Drills** ..... 147  
**Globe Valves**  
..... 31, 214-216  
**Gloves** ..... 155

**Greenline**..... 158  
**Grounding Reel,  
Static Electricity**.. 162  
**Guidemaster Parts** . 165  
**Guidemaster**... 162, 165

## H

**Halt - Dog Repellent**  
..... 155  
**Hammer, Brass** ..... 144  
**Hand Burners** ..... 209  
**Hand Pump, Krug**... 122  
**Hand Truck, Cylinder**  
..... 141-142  
**Heater Buddy**..... 210  
**Holders, Placard** ..... 94  
**Hose**  
Assemblies... 201, 211  
Braided..... 195, 197  
Camping..... 201, 211  
Coupling..... 196, 198  
Crimping Tools .... 194  
Extensions ... 202, 211  
Ferrules..... 194  
Grill ..... 201, 211  
Fittings  
..... 193, 194, 211, 212  
Motor Fuel ..... 195  
Pump Station 122, 135  
Replacements  
..... 201, 211  
Stainless Steel Braid  
..... 195  
Swivel ..... 39, 196  
**Hose Barb Fittings**  
..... 193-194  
**Hose Reels** ..... 161-164  
**Hose Reel Guides**  
..... 162, 164  
**I**  
**Injectors, Methanol** 159

**Inlet Fittings**..... 13, 14,  
46, 47, 202, 204, 210,  
211 212, 214  
**Insulating Unions**... 172  
**Internal Valves**  
Actuator ..... 51, 52, 54  
Accessories..... 51, 54  
Flanged ..... 52, 54  
Flomatic ..... 53  
Threaded..... 51  
**Inverted Flare Adapters**  
13  
**Inverter, Tank**..... 135

## J

**J - Clips** ..... 175  
**J - Wrench**..... 143  
**Jack, Tank**..... 143

## K

**Kits**  
Drill ..... 147  
Emergency Response  
156  
First Aid ..... 156  
Nipple..... 172  
Propane Test..... 153  
Reamer ..... 145  
Orifice ..... 147

## L

**Lead Acetate Paper** 153  
**Lead Seals** ..... 151  
**Leak Detector**..... 154  
**Lighters, Gas Match**  
..... 209  
**Lights, Service**..... 152  
**Liquid Leak Detector**  
..... 154  
**Litmus Paper**..... 153  
**Locator Tape** ..... 186

## Locks

Barrel ..... 129  
Breakaway..... 70, 129  
Caps..... 70  
Cylinder & Tank ..... 70  
POL..... 70

## M

**Magnesium Anode** ... 91  
**Magnetel Float Gauges**  
209  
**Manifold, Counterstrike**  
189  
**Manometer**  
Digital..... 150  
Water ..... 148  
**Mastic**..... 157  
**Match Holder**..... 144  
**Meter**  
Digital Clamp ..... 153  
Electrical Test..... 153  
Gas Detection  
..... 152, 154  
Liquid Flow ... 123-124  
Potential..... 158  
Vapor ..... 128  
**Meter Bar** ..... 128  
**Meter Seals, Lead** . 151  
**Methanol Injector**... 161  
**Mirror, Inspection** .. 151  
**Motor Fuel Hose** .... 195  
**Motor Fuel Tanks** 80, 81  
**Motors, Hose Reel** . 163  
**Mover, Cylinder**  
..... 141-142  
**Mr. Heater Buddy**... 210  
**Multimeter, Digital** 153  
**Multi-Port Flange,  
Repair Parts**..... 30  
**Multi-Port Manifolds  
for Storage Tanks**.. 30

**PRODUCTS**

**Multi-Port Relief Valves for Storage Tanks** ..... 29

**Multipurpose Valves**  
Filling & Liquid Transfer ..... 35  
Filling & Vapor Equalization ..... 35  
Liquid Withdrawal.. 35

**Multivalves**  
ASME Underground Tanks ..... 24  
ASME Vapor Withdrawal 22, 23, 80  
DOT - Liquid Withdrawal..... 21  
DOT - Vapor Withdrawal. 17, 21, 80  
DOT/ASME Vapor Withdrawal ... 17, 21

**N**

**Needle Valve** ..... 34

**Nipple Kit** ..... 172

**Nipple Tray**..... 172

**Nipples**  
Schedule 40 ..... 171  
Schedule 80 ..... 168  
Swage ..... 166

**Nitrogen Regulator** ..... 56, 119

**Nitrogen Tank**... 56, 119

**Non Sparking Tools** 144

**O**

**OPD Valves** ..... 20

**OPD Wrench**..... 160

**Orifice Kits** ..... 147

**Orifices**..... 147

**O-Rings** ..... 18, 75, 140

**Outdoor Valve Kit**... 198

**P**

**Paint** ..... 157

**Painting Equipment** 157

**Parts, Guidemaster** 165

**Permasert Fittings** ..... 179-182

**Pigtails** ..... 11-12

**Pigtails, Rubber**..... 200

**Pilot Cleaning Pump** .. 151

**Pin Vise** ..... 145

**Pipe**  
Coated Copper ..... 175  
Copper Tubing ..... 130, 176  
Counterstrike ..... 190  
Polyethylene..... 177  
Plastic ..... 177

**Pipe Dope**..... 154

**Pipe Fittings** ..... 166-169, 171-172

**Pipe Wrap** ..... 158

**Piping Decals**..... 91-95

**Pit Gauge**..... 159

**Placards** ..... 91-95

**Plastic Pipe**  
Brackets ..... 187  
Curb Box..... 186  
Cutters ..... 187  
Fittings ..... 179, 180  
Flex Riser ..... 182  
Pipe..... 177  
Risers..... 181  
Tapping Tees ..... 182  
Tools.... 185, 186, 187  
Transitions ..... 181  
Valve Wrench..... 186

**Plugs**  
ACME..... 42  
Flare ..... 172, 174  
Plastic .... 42, 172, 174  
POL 14, 135, 174, 202

Wood, Safety ..... 143

**Pneumatic Remote Control Kit**..... 56

**Pneumatic Tubing & Fittings**..... 56

**POL Adapters** ..... 13, 14, 43, 47, 174, 202, 210-212

**POL Locks** ..... 70

**POL Wrench** ..... 144

**Polyethylene Pipe**.. 177

**Portable Cylinders** ..... 68-69

**Potential Meter** ..... 158

**Press-Check Adapter**.... 149

**Press, Hand Seal** ... 151

**Pressure Gauge**..... 203

**Pressure Test Kit & Assemblies**..... 149

**Pull-Away Valve**56, 118

**Pumps**  
AutoGas..... 112  
Dispensing Stations - Coro-Flo..... 96-98  
Pilot Cleaning..... 151  
Stationary - Coro-Vane..... 99-105  
Stationary Z-Series ..... 99, 101, 103, 105  
Transport ..... 111, 114  
Truck..... 111, 114  
Truck - Z Series ..... 101, 102, 104

**Pump Station Hose** 122

**Pump Stations**. 130-134

**Pump Station Sign** ..... 91-95

**Purge Kit & Systems**.... 122

**Purge-It-Vac Adapter** 90, 122

**Purging Equipment** 122

**Q**

**Quick Disconnect Coupling** ..... 198, 212

**Quick-Acting Valves**  
**Crop Drier & Filling Manifolds**..... 38

**Delivery Truck & Dispensing Station** ..... 38, 39, 136, 214

**Hose End** ..... 38, 136, 213, 214

**R**

**Railroad Thermometer**158, 208

**Ratchet Straps**..... 142

**Reamer**..... 145

**Reels**  
Chains..... 163  
Electrical Parts ..... 163  
Grounding ..... 162  
Guide ..... 162  
Guidemaster. 162, 165  
Hose Reels.... 161-165  
Motors ..... 163  
Parts ..... 163-165  
Rollers ..... 164-165  
Sprockets..... 163  
Static Ground..... 162  
Switch ..... 163  
Swivel ..... 164

**Reflector, Triangle**. 143

**Registers**..... 127

**Regulators**  
Adjustable - High Pressure.... 7-9  
Auto Changeover ..... 3, 5, 199  
Commercial/Industrial ..... 7-10  
Compact - Single Stage..... 4

## PRODUCTS

### Regulators (cont.)

- Compact Twin Stage 2
- First Stage..... 1
- High Pressure  
.....7, 8,9, 200
- Maxitrol - In House.. 6
- Meter Assembly ... 128
- Nitrogen..... 56, 119
- Second Stage..... 1, 4
- Single Stage.4, 5, 199
- Twin Stage..2,3,5,199
- Twin Stage - Auto  
Changeover .3-5, 199
- Two Stage Kits..... 2

### Release, Remote

- Thermal** ..... 54

### Relief Valves

- Covers / Caps  
.....23, 25, 27
- External - Hydrostatic  
25
- External - Vapor  
.....23, 25, 26
- Forklift.....25, 77
- Internal - ASME  
Containers 26, 88, 89
- Internal - DOT Forklift  
Cylinders ..... 25, 77
- Internal - Large
- Storage  
Containers ..... 27
- Internal - Motor Fuel  
Containers  
.....27, 80, 82
- Internal - Transport &  
Delivery Vehicle .. 26
- Motor Fuel Tank 82, 85
- Pounds to Pounds
- Regulator ..... 8
- RV Tank ..... 82, 85

### Repair Kits

- Blackmer Pump ... 114

- Compressor . 120, 121
- Coro-Flow Pumps  
.....96-98
- Coro-Vane Pump  
.....100-105
- Cylinder, Multivalve &  
Plumbers Pot Valve  
..... 58, 59, 62-64
- Filler Valve ..... 60, 64
- Globe & Angle Valve ..  
61, 63
- Hose End Valve..... 60
- Liquid Meter..... 123
- Multivalve....59, 62-64
- Service Valve ... 58, 62
- Stationary Pumps  
.....99-101
- Truck Pumps  
..... 101, 102,114

### Repellent, Bee & Dog.. 155

### Replacement Parts

- Blackmer Pump ... 114
- Neptune ..... 127
- Tanks ..... 87-90, 206

### Requalification Stamps 159

### Retest Decals ..... 95

### Riser Pipe Clamp ..... 90

### Risers ..... 181, 182

### Roller Covers & Frames ..... 157

### Rollers, Hose Reel ..... 162, 164

### Roskote ..... 157

### Rotogauge ..... 208

### RV Brackets ..... 82

### RV Tanks ..... 83-84

### S

### Scales, Portable .... 133

### Schedule 40 Nipples.... 171

### Schedule 40 Pipe Fittings .169, 171-172

### Schedule 80 Nipples.... 168

### Schedule 80 Pipe Fittings ..... 166-168

### Scribe, Hand ..... 159

### Scrubber, Heavy End Separator ..... 139

### Seal Press ..... 151

### Seal, Copper ..... 173

### Sediment Traps..... 172

### Service Valves

- ASME ..... 17
- DOT ..... 17
- Flathead ..... 129
- Forklift.....18, 75
- Insulated Union.... 129
- Motor Fuel ..... 17
- Piping Systems..... 17

### Serviceman's Friend ..... 148

### Sherlock Leak Detector Fluid ..... 154

### Shield, Tubing..... 176

### Shut-Off Valve ..... 33-34

### Signs ..... 91-95

### Slings ..... 142

### Snubber ..... 148, 204

### Soap Detector Fluid 154

### Socket Fusion Fittings . 184

### Spanner Wrench .... 143

### Spring Bender ..... 146

### Stamps, Alpha- Numeric..... 159

### Stanchion, Breakaway . 118

### Stationary Tank Inverter..... 135

### Stopper Copper ..... 176

### Storage Tank Gauge ..... 207

### Strainers..... 117, 126

### Straps, Ratchet ..... 142

### Striker Plates, Counterstrike..... 189

### Suppressors ..... 14

### Swage Nipples ..... 166

### Swing Check Valve 116

### Switches, Reel..... 163

### Swivel, Hose Reel & Hose End Valve .... 39, 60, 164, 213, 214

### T

### Tank Anchoring ..... 86

### Tank Car Thermometer ..... 158, 208

### Tank Foot..... 211

### Tank Inverter, Stationary ..... 135

### Tank Jack ..... 143

### Tank Mover ..... 141

### Tank Stands..... 133

### Tank Thermometer ..... 158, 208

### Tanks

- ASME.... 79-81, 83-84
- Dispensers  
.....130-132, 134
- Nitrogen..... 56, 119
- Special Application,  
Vertical ..... 71

### Tape, Locator ..... 186

### Tape, Teflon ..... 154

### Tape, Wrapping .... 158

### Tapping Tees for Plastic Pipe ..... 182

### Tarlon ..... 157

### Tee Blocks..... 13



**PRODUCTS**

<b>Tees</b>	Plastic Pipe ..... 177	<b>Valves cont.</b>	<b>Weed Burners</b> ..... 209
Hose Adapters	Pneumatic..... 56	Fixed Liquid Level	<b>Wooden Plugs</b> ..... 143
.....202, 210, 211	<b>Tubing Cutter</b> ..... 146	Gauge ..... 57, 75	<b>Wrapping Tape</b> ..... 158
Three Way	<b>Tubing Shields</b> ..... 176	Flow Indicator ..... 50	<b>Wrenches</b>
.....210, 211, 212	<b>U</b>	Freeze Valve ..... 153	J - Type..... 143
<b>Teflon Tape &amp; Dope</b> 154	<b>Underground Coatings .</b>	Globe Valves ..... 31	Offset ..... 160
<b>Test Assembly, High</b>	157	Internal Valve ... 51-54	OPD ..... 160
<b>Pressure</b> ..... 149	<b>Underground Tanks</b> .....	Multi-Port Flange ... 30	POL..... 145
<b>Test Block, High</b>	87-88	Multi-Port Manifolds	Spanner ..... 143
<b>Pressure</b> ..... 149	<b>Unions, Insulating..</b> 172	..... 29, 30	Bot-L..... 160
<b>Test Kit, Low Pressure</b>	<b>V</b>	Multi-Port Relief	
..... 149	<b>Valve Kits</b>	Valves ..... 29	
<b>Test Kit, Propane</b>	Blackmer Pumps.. 132	Multipurpose Valve 35	
<b>Liquid</b> ..... 153	Corken Pumps ..... 131	Multivalve..... 22-24	
<b>Testers</b>	<b>Valves</b>	Needle Valve ..... 34	
Carbon Monoxide. 150	Accessories..... 21-27,	OPD Valves ..... 20	
Gas Detection	35-36, 51-54	Outdoor Outlet .... 198	
..... 152, 154	Adapter	Plastic Pipe ..... 186	
Meter ..... 153, 158	..... 18, 40, 41, 43, 47	Plug ..... 42	
Tiedown System for	Angle Valves .... 31, 36	Pneumatic..... 56	
Tanks..... 86	Back Check Valve.....	Pull-Away Valve	
<b>Thermocouples</b> ..... 144	49-50, 116	..... 56, 118	
<b>Thermometers</b>	Ball Valves ..... 32-34	Quick-Acting Valve 38,	
Container .... 158, 208	Bleeder Valves .57, 75	39	
Storage Tank 119, 208	Break-Away Valve	Relief Valve Covers 27	
Tank Car..... 158, 208	..... 56, 118	Relief Valves .... 25-30	
<b>Thermowell</b> .... 126, 208	Bypass Valves..... 113	Service Valves... 17-18	
<b>Thread Sealer</b>	Cables ..... 54	Thermal Release	
..... 154, 172, 174	Caps..... 42	Valves ..... 54	
<b>Threaded Plug</b>	Chek-Lok..... 36-37	<b>Vapor Meters</b> ..... 128	
..... 167, 169, 171	Connectors	<b>Vaporizers</b>	
<b>Torch, Weed Burner</b> 209	..... 18, 40, 43, 47	Direct Fired ..... 137	
<b>Torches</b> ..... 209	Counterstrike Ball	Electric ..... 138	
<b>Transitions</b> ..... 181	Valve ..... 189	Water Bath ..... 139	
<b>Tray, Nipple</b> ..... 172	Cylinder Valves	<b>Vise, Cylinder</b> ..... 160	
<b>Triangle Reflector</b> .. 143	..... 17-20, 80	<b>Vise, Pin</b> ..... 145	
<b>Truck Gauge</b> ... 207, 208	Emergency Shutoff 55		
<b>Trucks, Cylinder</b> ..... 142	Excess Flow Valve.....		
<b>Tube Holder</b> ..... 175	44-47		
<b>Tubing</b>	Filler Valve ..... 47-48		
Aluminum ..... 176		<b>W</b>	
Coated Copper ..... 175		<b>Warning Labels</b> ... 91-95	
Copper ..... 176		<b>Washers</b> ..... 140	
		<b>Water Manometer</b> .. 148	



# *Technical and Sales Training*

TARANTIN TANK AND EQUIPMENT COMPANY provides technical and sales training at each of our locations on a monthly basis. The schedules are listed on the web site at [www.tarantin.com](http://www.tarantin.com), and registration is available on-line. This training is free of charge and conducted by qualified instructors, culminating with certificates of completion.



OUR TRAINING SESSIONS are conducted as hands-on courses. Our highly skilled technical training staff provides a full range of instruction from regulator and line sizing to heater installation, troubleshooting and repair, to very technical aspects of pump, vaporizer and LPG plant installations. We also offer training on sales, codes, emergency response, rules and regulations.

OUR ON-THE-ROAD SALESPEOPLE are factory trained on the products we sell. All members of the inside and outside sales team have been CETP trained in several modules. As a distributor we believe it is our responsibility to offer training on the products/items we sell to ensure trouble-free installation and reduce costs.



**To sign up  
for our free  
training  
classes go to**

**[www.tarantin.com](http://www.tarantin.com)**

## RegO First Stage Regulators



### First Stage Regulators, High Pressure Domestic

Provides accurate first stage regulation in two-stage bulk tank systems. Reduces tank pressure to an intermediate pressure of 5 to 10 PSIG. Also used to supply high pressure burners for applications like industrial furnaces or boilers. Domestic LP-gas installations, also incorporated in multiple cylinder installations.

PART NUMBER	INLET CONNECTION	OUTLET CONNECTION	ORIFICE SIZE	FACTORY DELIVERED PRESSURE	INTEGRAL ADJUSTMENT RANGE	RELIEF VALVE INCLUDED	VAPOR CAPACITY BTU/HR. PROPANE
LV3403TR	1/4" F. NPT	1/2" F.NPT	1/4"	11	9-13	Yes	1,500,000
LV4403TR4	1/2" F. NPT	1/2" F. NPT	1/4"	10	5-10	Yes	2,500,000*
LV4403SR9	1/2" F. NPT	1/2" F. NPT	1/4"	5	1-5	Yes	2,500,000*
LV4403TR9	F. POL	1/2" F. NPT	1/4"	10	5-10	Yes	2,500,000*
LV4403SR96	F. POL	3/4" F. NPT	1/4"	5	1-5	Yes	2,500,000*
LV4403TR96	F. POL	3/4" F. NPT	1/4"	10	5-10	Yes	2,500,000*
LV3403TRV9	1/4" F. NPT	1/2" F. NPT	1/4"	10	-	Yes	1,500,000**

\* Maximum flow based on inlet pressure 20 PSIG higher than the regulator setting and delivery pressure 20% lower than the setting.

\*\* Vent at 9 o'clock.

## RegO Low Pressure Second Stage Regulators



### Second Stage Regulators Low Pressure, Domestic

Designed to reduce first stage pressure of 5 to 20 PSIG down to burner pressure, normally 11" WC. Ideal for medium commercial installations, multiple cylinder installations and normal domestic loads.

### Backmount Design

Mounts directly to house line piping. Eliminates need for union joints and elbows and mounting brackets. Quick and easy to install.

PART NUMBER	INLET CONNECTION	OUTLET CONNECTION	ORIFICE SIZE	FACTORY DELIVERED PRESSURE	ADJUSTMENT RANGE	VENT POSITION	VAPOR CAPACITY BTU/HR. PROPANE
LV4403B4	1/2" F. NPT	1/2" F. NPT	#28 Drill	11" WC at 10 PSIG Inlet	9" to 13" WC	Over Inlet	935,000
LV4403B46	1/2" F. NPT	3/4" F. NPT	#28 Drill	11" WC at 10 PSIG Inlet	9" to 13" WC	Over Inlet	935,000
LV4403B46R*	1/2" F. NPT	3/4" F. NPT	#28 Drill	11" WC at 10 PSIG Inlet	9" to 13" WC	Over Inlet	935,000
LV4403B66	3/4" F. NPT	3/4" F. NPT	#28 Drill	11" WC at 10 PSIG Inlet	9" to 13" WC	Over Inlet	935,000
LV4403B66R*	3/4" F. NPT	3/4" F. NPT	#28 Drill	11" WC at 10 PSIG Inlet	9" to 13" WC	Over Inlet	935,000
LV5503B4	1/2" F. NPT	3/4" F. NPT	1/4"	11" WC at 10 PSIG Inlet	9" to 13" WC	Over Inlet	1,600,000
LV5503B6	3/4" F. NPT	3/4" F. NPT	1/4"	11" WC at 10 PSIG Inlet	9" to 13" WC	Over Inlet	1,600,000
LV5503B8	3/4" F. NPT	1" F. NPT	9/32"	11" WC at 10 PSIG Inlet	9" to 13" WC	Over Inlet	2,300,000
LV4403B66RA**	3/4" F. NPT	3/4" F. NPT	3/16"	11" WC at 10 PSIG Inlet	9" to 13" WC	Over Inlet	1,000,000
LV4403B66R-AB**	3/4" F. NPT	3/4" F. NPT	3/16"	11" WC at 10 PSIG Inlet	9" to 13" WC	Over Inlet	1,000,000
LV3403B4	1/2" F. NPT	1/2" F. NPT	1/4"	11" WC at 10 PSIG Inlet	-	-	-

\* Backmount Design \*\* Sidemount Design

## RegO Low Pressure Second Stage Tobacco Barn Regulator

Especially developed for drying barns in the tobacco industry. The LV5503G4 regulator will supply a steady and constant flow of fuel to as many as 12 to 20 burners throughout the barn.



PART NUMBER	INLET CONNECTION	OUTLET CONNECTION	ORIFICE SIZE	FACTORY DELIVERED PRESSURE	ADJUSTMENT RANGE	VENT POSITION	VAPOR CAPACITY BTU/HR. PROPANE
LV5503G4	1/2" F. NPT	3/4" F. NPT	1/4"	15" WC at 15 PSI Inlet	8"-18" WC	Over Inlet	1,750,000

\*Maximum flow is based on 15 PSIG inlet and 13" WC delivery pressure.

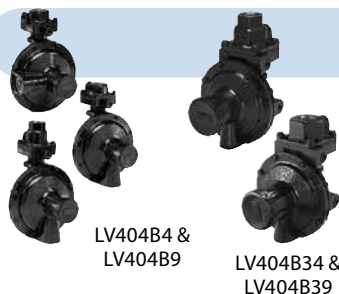

## RegO Compact Twin Stage Regulators

### Compact Twin Stage Regulators

This compact two-stage regulator is designed to reduce container pressure down to 11" WC delivery pressure. It is ideal for "on-site" cylinder applications, such as homes, mobile homes and average domestic service including small ASME and 100 to 420 pound DOT cylinders.

	PART NUMBER	INLET CONNECTION	OUTLET CONNECTION	ORIFICE SIZE	FACTORY DELIVERED PRESSURE*	ADJUSTMENT RANGE (2ND STAGE)	VENT POSITION (1ST STAGE)	VENT POSITION (2ND STAGE)	CAPACITY BTU/HR. PROPANE
LARGE	LV404B4	1/4" F. NPT	1/2" F. NPT	.219	11" WC at 100 PSIG Inlet	9"-13" WC	Down	Over Outlet	525,000
	LV404B4V9	1/4" F. NPT	1/2" F. NPT	.219	11" WC at 100 PSIG Inlet	9"-13" WC	9 o'clock	9 o'clock	525,000
	LV404B46	1/4" F. NPT	3/4" F. NPT	.219	11" WC at 100 PSIG Inlet	9"-13" WC	Down	Over Outlet	525,000
	LV404B46V9	1/4" F. NPT	3/4" F. NPT	.219	11" WC at 100 PSIG Inlet	9"-13" WC	9 o'clock	9 o'clock	525,000
	LV404B9	F. POL	1/2" F. NPT	.219	11" WC at 100 PSIG Inlet	9"-13" WC	Down	Over Outlet	525,000
	LV404B9V9	F. POL	1/2" F. NPT	.219	11" WC at 100 PSIG Inlet	9"-13" WC	9 o'clock	9 o'clock	525,000
	LV404B96	F. POL	3/4" F. NPT	.219	11" WC at 100 PSIG Inlet	9"-13" WC	Down	Over Outlet	525,000
	LV404B96V9	F. POL	3/4" F. NPT	.219	11" WC at 100 PSIG Inlet	9"-13" WC	9 o'clock	9 o'clock	525,000
SMALL	LV404B34	1/4" F. NPT	1/2" F. NPT	.100	11" WC at 100 PSIG Inlet	9"-13" WC	Rear	Over Outlet	450,000
	LV404B39	F. POL	1/2" F. NPT	.100	11" WC at 100 PSIG Inlet	9"-13" WC	Rear	Over Outlet	450,000
	LV404B34V9	1/4" F. NPT	1/2" F. NPT	.100	11" WC at 100 PSIG Inlet	9"-13" WC	Left	9 o'clock	450,000
	LV404B39V9	F. POL	1/2" F. NPT	.100	11" WC at 100 PSIG Inlet	9"-13" WC	Left	9 o'clock	450,000
	LV404Y9	F. POL	1/2" F. NPT	.219	2PSIG at 100 PSIG Inlet	1.8"-2.5" PSI	Down	Over Outlet	800,000**

\* Set at 100 PSIG inlet pressure to deliver gas from the second stage regulator at 11" WC.

\*\* Maximum flow based on 25 PSIG inlet pressure and 9" WC delivery pressure.



404PE



2302-55



2302-31

### Accessories

PART NUMBER	1ST STAGE PIPE-AWAY	2ND STAGE VINYL COVER	BRACKET
LV404B4 - LV404B96V9	404PE	-	-
LV404B34	404PE	2302-55	2302-31
LV404B39	404PE	2302-55	2302-31
LV404B34V9	404PE	2302-55	2302-31
LV404B39V9	404PE	2302-55	2302-31

## RegO Two Stage Regulator Kits

These outfits contain the equipment required to provide two-stage regulation.

KIT NUMBER	1ST STAGE REGULATOR INCLUDED		2ND STAGE REGULATOR INCLUDED		BRACKET INCLUDED	PIGTAIL INCLUDED	CAPACITY BTU/HR. PROPANE
	PART NUMBER	INLET X OUTLET FEMALE	PART NUMBER	INLET X OUTLET F. NPT			
5807	LV4403TR9	POL x 1/2" NPT	LV4403B4	1/2" x 1/2"	2503-22	913PS12	935,000
5808	LV4403TR9	POL x 1/2" NPT	LV4403B46R	1/2" x 3/4"	Not Required	913PS12	935,000
5820	LV4403TR96	POL x 3/4" NPT	LV4403B66R	3/4" x 3/4"	Not Required	913PS12	935,000



LV4403B



LV4403TR9

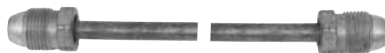

913PS12



2503-22

## RegO Twin Stage Automatic Changeover Regulators

PART NUMBER	SERVICE & RESERVE INDICATOR	INLET CONNECTION	OUTLET CONNECTION	FACTORY DELIVERED PRESSURE*	ADJUSTMENT RANGE	VENT POSITION	CAPACITY BTU/HR. PROPANE**	BRACKET INCLUDED
7525B34	Integral	1/4" Inverted Flare	1/2" F. NPT	11" WC	9"-13" WC	Over Outlet	400,000	2302-31
7525B4	Integral	1/4" Inverted Flare	1/2" F. NPT	11" WC	9"-13" WC	Over Outlet	450,000	2503-22

\* Set at 100 PSIG inlet pressure.

\*\* Maximum flow based on 25 PSIG inlet pressure and 9" WC delivery pressure.

### Application:

These combination automatic changeover, two stage regulators are especially suitable for homes, mobile homes, cottages, construction and other portable two cylinder installations. Empty containers may be replaced without interrupting customer's gas service.

### Features:

- Automatic changeover switches from "service" to "reserve" cylinder automatically without interrupting service.
- The Second Stage Incorporates wide bonnet drip lip vent to guard against freeze-up when properly installed.
- With 15 PSIG inlet pressure, the second stage regulator is designed to not pass more than 2 PSIG with the seat disc removed.
- Allows "reserve" cylinder to supplement the flow of gas from the "service" cylinder during extreme load or severe cold conditions.
- Incorporates molded diaphragm in second stage regulators.
- Integral indicator gauge.
- Change over knob and indicator are integral to the first stage.
- Select brown finish on first stage.



7525B34

7525B4



2302-31



2503-22

## RegO Twin Stage Automatic Changeover Regulator Kits

OUTFIT NUMBER	AUTOMATIC CHANGEOVER INCLUDED	INLET CONNECTION	OUTLET CONNECTION	PIGTAILS INCLUDED (2)	HEX SIZE CONNECTORS	BRACKET INCLUDED	CAPACITY BTU/HR. PROPANE
5727B34	7525B34	1/4" Inverted Flare	1/2" F. NPT	912FS20	7/8" Short	2302-31	400,000
5754B4	7525B4	1/4" Inverted Flare	1/2" F. NPT	912FA20	1-1/8" Long	2503-22	450,000
5755B4	7525B4	1/4" Inverted Flare	1/2" F. NPT	912FS20	7/8" Short	2503-22	450,000

### Features:

- Includes new pigtails. This helps insure that new pigtails are installed along with the regulator.
- Features, designs, and performance characteristics of the individual components may be found under the appropriate section of this catalog.



7525B34

7525B4



2503-22



2302-31



912FS20

## RegO Single Stage Compact Regulators



These compact regulators are designed for smaller outdoor grills and fish cookers. They are intended for use on small portable appliances that use 100,000 BTUs/hr. or less. They may not be used on fixed pipe systems per NFPA 58, 1995 edition.

PART NUMBER	INLET CONNECTION	OUTLET CONNECTION	ORIFICE SIZE	FACTORY DELIVERY PRESSURE	ADJUSTMENT RANGE	BONNET VENT POSITION	VAPOR CAPACITY BTU/HR. PROPANE*
302	1/4" F.NPT	3/8" F.NPT	#50 Drill	11" WC at 100 PSIG inlet	9-13" WC	Small Vent Above Inlet	125,000
302V	1/4" F.NPT	3/8" F.NPT	#50 Drill	11" WC at 100 PSIG inlet	9-13" WC	Drip Lip Above Inlet	125,000
302V9	1/4" F.NPT	3/8" F.NPT	#50 Drill	11" WC at 100 PSIG inlet	9-13" WC	Drip Lip at 9 o'clock	125,000
302V9LS	Soft POL w/o orifice	3/8" F.NPT	#50 Drill	11" WC at 100 PSIG inlet	9-13" WC	Drip Lip at 9 o'clock	125,000

## RegO Second Stage Regulator For 2 PSIG Systems



Designed to reduce first stage pressure of 10 PSIG down to 2 PSIG. A line pressure regulator is required downstream to reduce the 2 PSIG to a nominal 11" WC.

PART NUMBER	INLET CONNECTION	OUTLET CONNECTION	ORIFICE SIZE	FACTORY DELIVERY PRESSURE	ADJUSTMENT RANGE	VENT POSITION	CAPACITY BTU/HR. PROPANE
LV404Y9	F.POL	1/2" FNPT	.219	2 PSIG @ Tank Pressure	1.8 to 2.5	Down	800,000
LV4403Y46R*	1/2" F.NPT	3/4" F.NPT	1/4"	2 PSIG @ 10 PSIG Inlet	1.8 to 2.5	Over Inlet	1,000,000
LV5503Y6	3/4" FNPT	3/4" FNPT	1/4"	2 PSIG @ 10 PSIG Inlet		Over Inlet	2,200,000
LV5503Y8	3/4" FNPT	1" FNPT	9/32"	2 PSIG @ 10 PSIG Inlet		Over Inlet	2,200,000
LV4403Y4	1/2" F.NPT	1/2" F. NPT	1/4"	2 PSIG @ 10 PSIG Inlet	1.8 to 2.5	Over Inlet	1,000,000

\*Backmount Design

## Fairview Twin Stage Regulator



299-GR9959

The model GR-9950 and GR-9959 regulators combine both a high pressure first stage and a low pressure second stage regulator into a single unit. Ideally designed for RV applications, these regulators ensure a smooth and continuous flow of gas to all appliances.

PART NUMBER	DESCRIPTION
290-GR9950	Vent Over Outlet
299-GR9959	9 o'clock Vent

### SPECIFICATIONS:

- Zinc Die Cast
- Molded Rubber Diaphragms
- UL Listed
- 2nd Stage Relief Mechanism Per U.L. 144
- Adjusting Screw and Dust
- Cap Design

## Fairview Automatic Changeover Regulators



254-GR9984

### Low Pressure Two-Stage Automatic Changeover

Automatically redirects LP gas vapor flow from an empty designated service cylinder to a reserve cylinder without interruption of service. It features a green indicator dome which changes to red when the service cylinder needs to be refilled.

### SPECIFICATIONS:

- Zinc Die Cast
- Molded Rubber Diaphragms
- UL Listed
- 2nd Stage Relief Mechanism Per U.L. 144
- Powder Coated

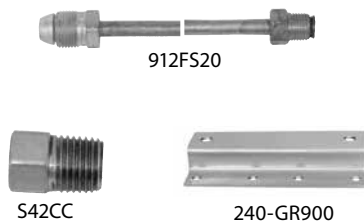

912FS20

S42CC

240-GR900

PART NUMBER	DESCRIPTION
254-GR9984	Regulator
254-GR9984P	Regulator Carded
912FS20	1/4" Inv. Flare x POL 1/4" Tube with 7/8" Hex
240-GR900	Regulator Z-Bracket
S42CC	Connector 1/4" Inverted Flare x 1/4" MPT

## Fairview Single Stage Regulators

### Low Pressure Single-Stage Regulators

The model GR-800 regulator incorporates a drip lip vent and is ideally suited for use with portable devices.

### SPECIFICATIONS:

- Zinc Die Cast
- Molded Rubber Diaphragm
- Underwriters Laboratories Listed
- Integral Pressure Relief



230-GR866  
ACME Connector

G-1851-A02  
ACME Connector



### Marshall Excelsior Connectors

PART NUMBER	DESCRIPTION	CAPACITY BTU/HR. PROPANE
G-1851-A02	Type 1 QCC x 1/4 MPT Black	0-70,000
G-1851-A03	Type 1 QCC x 1/4 MPT Green	71,000-200,000
G-1851-A04	Type 1 QCC x 1/4 MPT Red	201,000-400,000



230-GR800  
Drip Lip Vent



230-GR856  
with POL installed

## Maxitrol Regulators

ALL MAXITROL REGULATORS COME WITH THE VENT LIMITER INSTALLED. ALSO AVAILABLE WITHOUT.



325-3L



325-5L-1



325-3L48



325-3BL



13A15  
Vent Protector

### Maxitrol 325 Series Regulators

325 Series pounds to inches regulators are for use on residential, commercial, and industrial applications. The 325 Series features a high leverage valve linkage assembly to deliver positive dead-end lock-up. The regulators are capable of precise regulating control from full flow down to pilot flow.

#### B Models:

Imblue Technology™ increases corrosion resistance and provides extra protection against the elements for regulators used in outdoor applications.

PART NUMBER	INSIDE VENT LIMITER	INLET/OUTLET CONNECTION	OUTSIDE VENT PROTECTOR	SETTING OF SPRING	SPRING RANGE	BTU CAPACITY WITH SINGLE APPLIANCE	BTU CAPACITY ALL APPLIANCES COMBINE
325-3	12A09	3/8"	13A15	11" W.C	7-11" W.C	140,000	250,000
325-3L	12A09	1/2"	13A15	11" W.C	7-11" W.C	140,000	250,000
325-3BL	12A09	1/2"	13A15	11" W.C	7-11" W.C	140,000	250,000
325-5L	12A39	3/4"	13A15-5	11" W.C	7-11" W.C	300,000	600,000
325-5L-1	12A39	1"	13A15-5	11" W.C	7-11" W.C	300,000	600,000
325-5L-1/2	12A39	1/2"	13A15-5	11" W.C	7-11" W.C	300,000	600,000
325-5BL	12A39	3/4"	13A15-5	11" W.C	7-11" W.C	300,000	550,000
325-7L	12A49	1-1/4"	13A25	11" W.C	7-11" W.C	1,250,000	1,250,000
325-7BL	12A49	1-1/4"	13A25	11" W.C	7-11" W.C	1,250,000	1,250,000

## Maxitrol Regulators with OPD

The 325 Series with OPDs features a high leverage valve linkage assembly to deliver positive dead-end lock-up. The regulators are capable of precise regulating control from full flow down to pilot flow.

PART NUMBER	OPD TYPE	INLET/OUTLET CONNECTION	SETTING OF SPRING	SPRING RANGE	BTU CAPACITY WITH SINGLE APPLIANCE	BTU CAPACITY ALL APPLIANCES COMBINED
325-3L48	w/OPD 48 attached	1/2"	11" W.C	7-11" W.C.	200,000	
325-5L48	w/OPD 48 attached	3/4"	11" W.C	7-11" W.C.	235,000	
325-5L600-3/4	w/OPD 600 attached	3/4"	11" W.C	7-11" W.C.	425,000	



## High Pressure Industrial/Commercial Pounds-to-Pounds Regulators



597F



Designed to reduce propane gas container pressure down to between 3 and 100 PSIG. Ideal for liquid or vapor service, they can be used in a variety of applications, including salamander heaters, weed burning toches, fish cookers, tar pot heaters and other industrial type services.

### FEATURES:

- Provides high capacity performance at a reasonable price
- Suitable for both liquid and vapor service.
- Compact design provides easy installation
- Consistent delivery pressure, especially in cold weather, helps assure maximum performance from the second stage regulator

PART NUMBER	ADJUSTMENT METHOD	INLET & OUTLET	RECOMMENDED DELIVERY PRESSURE RANGE (PSIG)	CAPACITY*	CAPACITY**
597FA	Tee Handle	1/4" NPT	1-15	10	1,750,000
597FB	Tee Handle	1/4" NPT	10-30	20	3,000,000
597FC	Tee Handle	1/4" NPT	20-45	30	3,500,000
597FD	Tee Handle	1/4" NPT	40-100	40	4,500,000

\* Set pressure established at 100 PSIG inlet and flow of 250,000 BTU/hr.

\*\* Capacity determined at actual delivery pressure 20% less than set pressure with inlet pressure 20 PSIG higher than the set pressure.



1584VN

## High Pressure Industrial / Commercial Regulators

Designed to reduce container pressure to between 3 and 125 PSIG. Precision-built with a multi-million BTU capacity. Ideal as a first stage regulator in large, multiple container operations. Also ideal for crop dryers, asphalt plants and "tar wagons." Large nozzle and straight through flow provides capacity and resistance to freeze up. Suitable for both liquid and vapor service. Can be readily fitted with pressure gauge or 3139 series relief in 1/4" F.NPT port.

PART NUMBER	SERVICE	ADJUSTMENT METHOD	INLET & OUTLET CONNECTION	RECOMMENDED DELIVERY PRESSURE RANGE (PSIG)	WIDTH	HEIGHT (MAX.)	CAPACITY DETERMINED AT SET PRESSURE OF PSIG	CAPACITY*
1584VN	LP-Gas	Tee Handle	1/2" F.NPT	3-30	2 15/16"	4 7/8"	20	7,000,000
1584VL	LP-Gas	Tee Handle	1/2" F.NPT	25-50	2 15/16"	4 7/8"	30	7,500,000
1584VH	LP-Gas	Tee Handle	1/2" F.NPT	45-125	2 15/16"	4 7/8"	60	8,000,000
1586VN	LP-Gas	Tee Handle	3/4" F.NPT	3-30	3.5"	7"	20	11,000,000
1586VL	LP-Gas	Tee Handle	3/4" F.NPT	25-50	3.5"	7"	30	12,000,000
1586VH	LP-Gas	Tee Handle	3/4" F.NPT	45-125	3.5"	7"	60	14,000,000
1588VN	LP-Gas	Tee Handle	1" F.NPT	3-30	3.5"	7"	20	11,000,000
1588VL	LP-Gas	Tee Handle	1" F.NPT	25-50	3.5"	7"	30	12,000,000
1588VH	LP-Gas	Tee Handle	1" F.NPT	45-125	3.5"	7"	60	14,000,000

Care must be taken to prevent re-liquefaction of propane at normal temperatures by heat tracing or other effective means. Use of a relief valve downstream of these regulators is recommended in accordance with NFPA 58.

\* Capacities determined at actual delivery pressure 20% less than set pressure with inlet pressure 20 PSIG higher than set pressure.

## High Pressure/High Temperature Industrial/Commercial Pounds-to-Pounds Regulators

### Application:

Designed to reduce LP-gas container pressures to between 3 and 50 PSIG. Ideal for crop drying, heat treating, asphalt batch mixing and other large industrial and commercial load application utilizing high temperature LP gas or high temperature atmosphere under conditions up to 300°F. Also ideal as a first stage regulator in large multiple operations.

### FEATURES:

- Special diaphragm and seat materials are suitable for up to 300°F. temperatures.
- Large nozzle and straight through flow provides high capacity and resistance to freeze ups.
- Suitable for both liquid and vapor service.
- Can be fitted with high pressure gauge in 1.4" F. NPT port. Engineered Controls International, Inc. recommends that these gauges use silver braze rather than soft solder construction.



X1586VN

PART NUMBER	SERVICE	ADJUSTMENT METHOD	INLET & OUTLET CONNECTIONS	RECOMMENDED DELIVERY PRESSURE RANGE (PSIG)	CAPACITY DETERMINED AT SET PRESSURE OF PSIG*	CAPACITY BTU/HR PROPANE**
X1584VN	LP-Gas	Tee Handle	1/2" F.NPT	3-30	20	7,000,000
X1584VL	LP-Gas	Tee Handle	1/2" F.NPT	25-50	30	7,500,000
X1586VN	LP-Gas	Tee Handle	3/4" F.NPT	3-30	20	11,000,000
X1586VL	LP-Gas	Tee Handle	3/4" F.NPT	25-50	30	12,000,000

\* Set pressure is established with 100 PSIG inlet pressure and a flow of 500,000 BUT/hr propane.

\*\* Capacities determined at actual delivery pressure 20% less than set pressure with inlet pressure 20# PSIG higher than set pressure.

NOTE: Care must be taken to prevent re-liquidation of propane at normal temperatures by heat tracing or other effective means. Use of a relief valve upstream or downstream of these regulators is recommended in accordance with NFPA 58.

## Vapor Relief Valves for Pounds-to-Pounds Regulators

### 3139 Series Application

Designed for use as a relief valve on first stage regulators that comply with the NFPA58 2.5.7.5 exception: "first stage regulators with a rated capacity of more than 500,000 BTU/hr. shall be permitted to have a separate relief valve."

### FEATURES:

- Pop-action design keeps product loss to a minimum.
- Suitable for use downstream of 1580 series regulators on vapor systems to comply with NFPA 58.
- May be installed with either the regulator pressure gauge port or on a fitting downstream from the regulator outlet.
- Constructed of non-corrosive brass.



3139-18

PART NUMBER	RELIEF VALVE SETTING	REGULATOR SET PRESSURE	CONNECTION SIZE	HEIGHT	WIDTH
3139-18	18 PSIG	10 PSIG	1/4" MNPT	2-27/32"	1-1/16"
3139-26	26 PSIG	15 PSIG	1/4" MNPT	2-27/32"	1-1/16"
3139-38	38 PSIG	20 PSIG	1/4" MNPT	2-27/32"	1-1/16"

## Belgas Commercial/Industrial High Pressure Pounds-to-Pounds Regulators



R627 SERIES  
includes Internal Relief



P627 SERIES

PART NUMBER	INLET	OUTLET	ORIFICE	ADJUSTMENT RANGE	OUTLET PRESSURE SETTING	VERSION	BTU/HR CAPACITY
P627-3/4	3/4"	3/4"	1/2"	5-20 PSI	10PSI	Non Relief	10,851,000
P627-1	1"	1"	1/2"	5-20 PSI	10 PSI	Non Relief	10,867,000
P627-2	2"	2"	1/2"	5-20 PSI	10 PSI	Non Relief	10,263,000
P627CA-200	2" NPT	2" NPT	1/2"	5-20 PSI	15 PSI	Operator	7,600,000

*Additional options available - contact a Tarantin representative for more information.*

## Belgas Low Pressure Second Stage Regulators



B34 SERIES



B34SR SERIES



B38 SERIES

### Intermediate Commercial

The B34 service regulator is a versatile, large diaphragm-controlled regulator designed for commercial and industrial loads. The B34 maintains accurate regulation on applications where frequent sudden load changes can occur.

The B38 service regulator is designed for use on large commercial and industrial loads. Large orifices are available (up to 1 3/8") for high capacity/low inlet pressure applications. An added feature of the B38R is its massive relief capacity.

PART NUMBER	INLET	OUTLET	ORIFICE	ADJUSTMENT RANGE	OUTLET PRESSURE SETTING	INTERNAL RELIEF VALVE	BTU/HR CAPACITY
B34RGJ-200	1-1/4"	1-1/4"	1/2"	1-2 PSI	2 PSI	Yes	4,200,000
B34SRQF-125	1-1/4"	1-1/4"	3/8" x 1/2"	8-12" WC	11" WC	Yes	5,019,000
B38RVJ-200	2"	2"	1"	1-2 PSI	2 PSI	Yes	12,800,000

### Light Commercial

The B42 service regulator incorporates a molded diaphragm and increased lever ratio into a conventionally designed regulator. The result is a lighter, more compact unit that provides the power, capacity, and relief performance of much larger regulators.



B42 SERIES



B31R SERIES



B42R SERIES

PART NUMBER	INLET	OUTLET	ORIFICE	ADJUSTMENT RANGE	OUTLET PRESSURE SETTING	INTERNAL RELIEF VALVE	BTU/HR CAPACITY
B31R-1-1/4	1-1/4"	1-1/4"	3/8"	8-12" WC	11" WC	Yes	3,305,000
B42R-1/2	1/2"	1/2"	1/4"	6-16" WC	11" WC	Yes	1,331,000
B42R-3/4	3/4"	3/4"	5/16"	6-16" WC	11" WC	Yes	1,713,000
B42R-1-1/4	1-1/4"	1-1/4"	3/8"	6-16" WC	11" WC	Yes	1,923,000

*Additional options available - contact a Tarantin representative for more information.*

## Pigtails

Pigtails are available in a variety of connections, sizes and styles. Care should always be taken in selecting the proper pigtails for a particular application.

Note: Tarantin Industries recommends a new pigtail be installed with every new and replaced regulator.

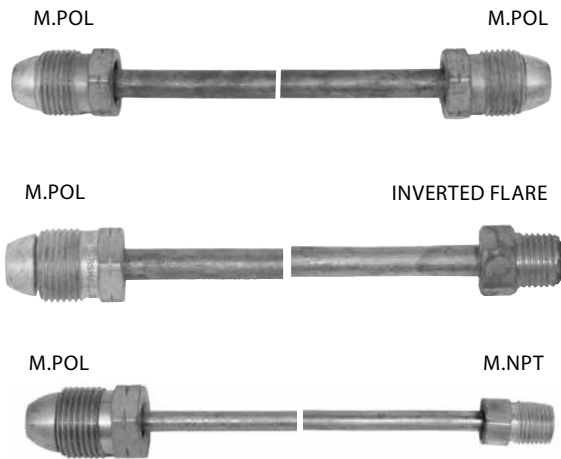

### Straight Pigtails

CONNECTIONS	APPROXIMATE LENGTH	PART NUMBER		
		1/4" TUBE		3/8" TUBE
		7/8" HEX SHORT NIPPLE	1 1/8" HEX LONG NIPPLE	7/8" HEX SHORT NIPPLE
M. POL x M. POL	5"	-	-	913PS05
M. POL x M. POL	12"	912PS12	-	913PS12
M. POL x M. POL	20"	912PS20	912PA20	913PS20
M. POL x M. POL	30"	912PS30	-	913PS30
M. POL x M. POL	36"	912PS36	912PA36	913PS36
M. POL x M. POL	48"	912PS48	912PA48	913PS48
1/4" Inverted Flare x M. POL	12"	912FS12	-	-
1/4" Inverted Flare x M. POL	20"	912FS20	912FA20	-
1/4" Inverted Flare x M. POL	30"	912FS30	-	-
1/4" Inverted Flare x M. POL	36"	912FS36	-	-
1/4" Inverted Flare x M. POL	48"	G-1674-48	-	-
1/4" M. NPT x M. POL	5"	-	-	913JS05
1/4" M. NPT x M. POL	12"	912JS12	-	913JS12
1/4" M. NPT x M. POL	20"	912JS20	G-1662-20	913JS20
1/4" M. NPT x M. POL	36"	912JS36	G-1662-36	-
1/4" M. NPT x M. POL	48"	-	G-1662-48	-
1/2" M. NPT x M. POL	12"	-	-	913LS12

### Bent Pigtails

CONNECTIONS	LENGTH	PART NUMBER 3/8" TUBE 7/8" HEX SHORT NIPPLE	TYPE/DEGREE OF BEND
1/4" M.NPT x M. POL	5"	913JS05A	90°
M. POL x M. POL	5"	913PS05A	90°
M. POL x M. POL	12"	913PS12G	270° Right Hand

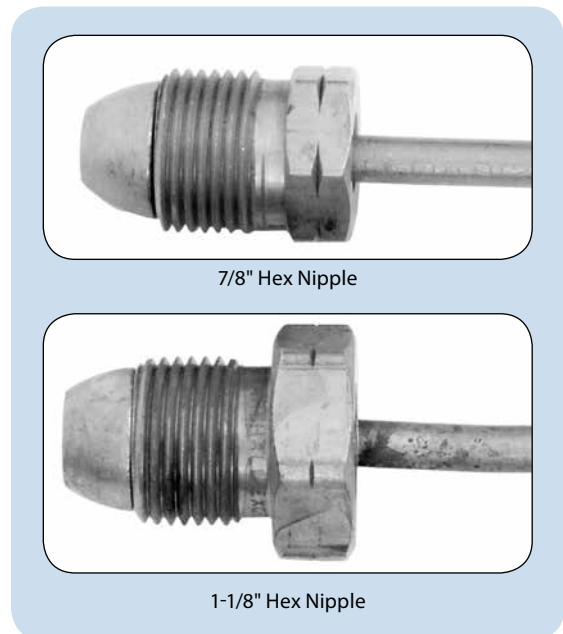
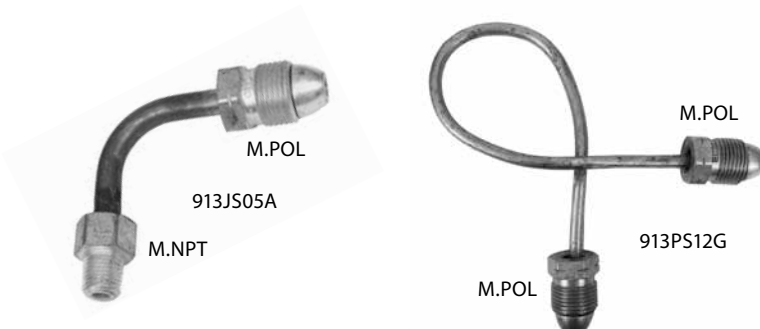

## Pigtails

### Electrically Isolated Pigtails

Dielectric Pigtails are primarily used on underground container installations to isolate the tank from the underground piping systems. They can also be used anywhere you need to electrically isolate the tank from the piping system.

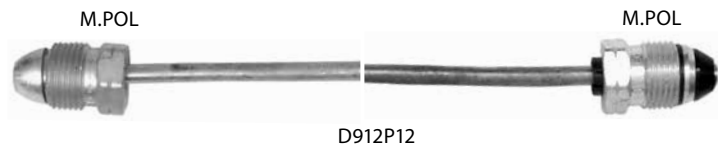

CONNECTIONS	LENGTH	PART NUMBER	
		7/8" HEX SHORT NIPPLE	
		1/4" TUBE	3/8" TUBE
M. POL x M. POL	12"	D912P12	D913P12
M. POL x M. POL	20"	D912P20	D913P20
M. POL x M. POL	30"	D912P30	D913P30
1/4" M. NPT x M. POL	12"	D912J12	D913J12
1/4" M. NPT x M. POL	20"	D912J20	D913J20
1/4" M. NPT x M. POL	30"	D912J30	D913J30

### Presto-Tap Pigtails

Presto tap Pigtails are designed to take the place of a conventional pigtail. They allow the service tech or driver to perform a pressure test without disconnecting the pigtail from the tank. The design of the pigtail saves time and cuts down on lost propane due to its patented design.

CONNECTIONS	LENGTH	PART NUMBER 3/8" TUBE 7/8" HEX SHORT NIPPLE
M. POL x M. POL	12"	PT912PS12
M. POL x M. POL	20"	PT912PS20
M. POL x M. POL	48"	PT912PS48
1/4" M. NPT x M. POL	12"	PT912JS12
1/4" M. NPT x M. POL	20"	PT912JS20
1/4" Inv. Flare x M. POL	20"	PT912FS20

PART NUMBER	OUTLET
RV	1/8" Pressure Valve w/Flow Control



## Tee Blocks

Use with suitable pigtails to connect multiple cylinders together. Ideal for loads that require more than one cylinder to be in service at a time. Provides a three-way tee function when not equipped with an internal disc check.

PART NUMBER	PART NUMBER	CHECK	INLET	OUTLET
1350E	MSCP-1701B	No	FPOL	MPOL 7/8" Hexnut
1350R	1701A	Yes*	FPOL	MPOL 7/8" Hexnut
1450E	G-1701	No	1/4" IN FL	1/4" MPT
1450R	G-1700	Yes*	1/4" IN FL	1/4" MPT
-	1702A	Yes*	FPOL	MPOL 1 1/8" Hexnut
-	1702B	No	FPOL	MPOL 1 1/8" Hexnut
-	1701X	Ex Flow	FPOL	MPOL 7/8" Hexnut
-	1701F	No	FPOL	FPOL

\* For use in systems that require uninterrupted gas service during cylinder exchange. Especially for summer cottages, mobile homes and single appliance loads. Floating disc check minimizes discharge of gas to the atmosphere when empty cylinder is being replaced.

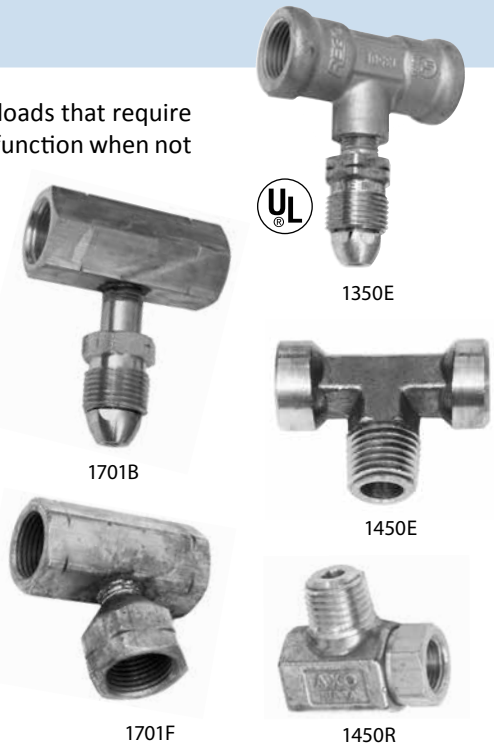

## Single Piece Pol Adapters



5760B

TYPE NUMBER BRASS	OTHER CONNECTION	POL CONNECTION
5760A	1/4" F. NPT	F. POL
5760B	3/8" F. NPT	F. POL
5760C	1/2" F. NPT	F. POL
5760D	3/4" F. NPT	F. POL
1703	F. POL	F. POL



2906A

TYPE NUMBER BRASS	OTHER CONNECTION	POL CONNECTION
2906A	1/4" F. NPT	M. POL
2906G	1/2" F. NPT	M. POL



5761D

TYPE NUMBER BRASS	OTHER CONNECTION	POL CONNECTION
5761A	1/4" M. NPT	F. POL
5761B	3/8" M. NPT	F. POL
5761C	1/2" M. NPT	F. POL
5761D	3/4" M. NPT	F. POL

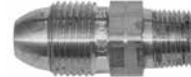

2906D

TYPE NUMBER BRASS	OTHER CONNECTION	POL CONNECTION
2906D	3/8" M. NPT	M. POL
BG20E	3/8" SAE FLARE	M. POL
BG20F	1/2" SAE FLARE	M. POL
BG20I	5/8" SAE FLARE	M. POL

## Inverted Flare Adapters



S42CC

PART NUMBER	OUTLET
S42CC	1/4" M. NPT x 1/4" F. Inverted Flare Inlet Adapter
RV	1/8" Pressure Valve w/Flow Control



RV

## RegO POL Excess Flow Adapters

Designed for use on LP-gas ASME container manifolds where excess flow protection may be required for the vapor (POL) vapor outlet connections. POL X 1/2" MPT



3188A

PART NUMBER	LIQUID CLOSING FLOW GPM	APPROXIMATE CLOSING FLOWS			
		10 PSIG INLET	25 PSIG INLET	100 PSIG INLET	125 PSIG INLET
3188A	0.95	160	210	350	420
3188B	1.9	310	400	700	840
3188C	2.9	510	660	1180	1430

## POL Inlet Fittings

All fittings have 1/4" M. NPT connections and are machined from brass with 7/8" Hex nut or handwheel.

PART NUMBER	PART NUMBER	DESCRIPTION
970	G-1675	Hard nose POL with wrench nut
970AX	G-1690	Hard nose POL with wrench nut and excess flow
970AS	G-1641	Soft nose POL with wrench nut and excess flow
3199W	G-1690	Heavy duty hard nose POL with wrench nut and excess flow
970AW	G-1654A	Soft nose POL with handwheel
-	G-1654	Soft nose POL with Black Plastic handwheel
970HT	-	Soft nose POL with handwheel and 60 DMS orifice
970S	G-1638	Soft nose POL with Wrench nut and 60 DMS orifice
-	737-5	POL Red Safety Plug with Strap



## Suppressors

The Series 1493 suppressor assemblies attached to the vent or vent piping prevents pulsation, and in addition, when properly installed, protects against the accumulation of snow and ice on the vent opening. It is equipped with a screen to exclude insects.

PART NUMBER	APPLICATION
1493	Installed directly on vent piping 3/8-1/2"
1493D	1/4" M. NPT Tailpiece



1493

1493D



**Regulator Covers**

By covering your gas pressure regulator, you can maintain vent limiter protection AND prevent cold-weather problems.

PART NUMBER	FITS REGULATOR SERIES
MAXICAP-3R	325-3
MAXICAP-5R	325-5
MAXICAP-7R	325-7 & 210D



MAXICAP-3R



MAXICAP-5R



MAXICAP-7R

**Brackets**

RegO brackets are especially designed for use in installing RegO regulators in applications requiring the use of a bracket.

PART NUMBER	MATERIAL	FOR USE WITH REGULATOR MODEL
2302-31	Cadmium Plated Steel	3303 Series / 404B23
2503-22	Cadmium Plated Steel	LV404 Series, 2503 Series, LV4403 Series
2503-19	Aluminum	LV404 Series, 2503 Series, LV4403 Series



2503-19



2503-22



2302-31

PART NUMBER	APPLICATION
240-GR900	Z-Mounting Bracket Pre-drilled to attach to regulators horizontally or vertically. Allows the regulator to be mounted from the front to any surface



240-GR900

## RegO<sup>®</sup> Regulator Selection

In order to properly size the RegO<sup>®</sup> Regulator, find the total load of the installation. The total load is calculated by adding up the input ratings (BTU or CFH) of all appliances in the installation. Input ratings may be obtained from the nameplates on the appliances or from the manufacturers' literature.

Determine the type of regulation needed referring to the chart below.

TYPE OF SYSTEM	MAXIMUM LOAD	SUGGESTED REGULATOR
First Stage in a Two Stage System	1,500,000	LV3403TR
	2,500,000	LV4403SR Series LV4403TR Series
Second Stage in a Two Stage System	450,000	LV3403B Series
	935,000	LV4403B Series
	1,600,000	LV5503B4/B6
	2,300,000	LV5503B8
Second Stage in a 2 PSIG System	9,800,000	LV6503B Series
	1,000,000	LV4403Y4/Y46R
	2,200,000	LV5503Y6/Y8
	Integral Twin Stage	450,000
525,000		LV404B4/B9 Series
800,000		LV404Y9
Automatic Changeover	200,000	7525B34 Series
	450,000	7525B4 Series

\* See RegO L500 Catalog for inlet and delivery specifications.

Now determine which regulator in the Series would be most suitable. Turn to the individual product pages and refer to the Performance Curves. Check the performance of the regulator with your actual load conditions at the minimum LP-Gas inlet pressure for the regulator. Use the pressure corresponding to your lowest winter temperatures shown in the chart below or refer to the delivery pressure of your first stage regulator.

TEMPERATURE		APPROX. PRESSURE (PSIG)		TEMPERATURE		APPROX. PRESSURE (PSIG)	
°F	°C	PROPANE	BUTANE	°F	°C	PROPANE	BUTANE
-40	-40	3.6	-	40	4	72	3.0
-30	-34	8	-	50	10	86	6.9
-20	-29	13.5	-	60	16	102	12
-10	-23	23.3	-	70	21	127	17
0	-18	28	-	80	27	140	23
10	-12	37	-	90	32	165	29
20	-7	47	-	100	38	196	36
30	-1	58	-	110	43	220	45

### Example for a First Stage Regulator

1. Assume a load of 500,000 BTU's per hour.
2. Assume a minimum delivery pressure of 9.5 PSIG.
3. Assume a minimum tank pressure of 15 PSIG.

4. For these conditions, refer to chart for the LV4403TR Series, First Stage Regulator, shown below.
5. Find the line on the chart corresponding to the lowest anticipated winter tank pressure (note that each performance line corresponds to and is marked with a different inlet pressure in PSIG).
6. Draw a vertical line upward from the point of assumed load (500,000 BTU's per hour) to intersect with the line corresponding to the lowest tank pressure.
7. Read horizontally from the intersection of these lines to the delivery pressure at the left side of the chart. In this example the delivery pressure will be 9.7 PSIG. Since the delivery pressure will be 9.7 PSIG at the maximum load conditions and lowest anticipated tank pressure, the regulator will be sized properly for the demand.

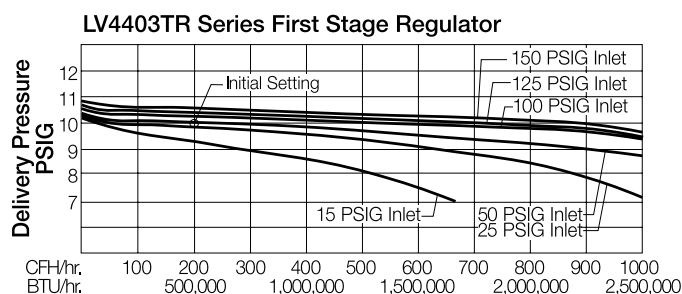

### Example for a Second Stage Regulator

1. Assume load of 250,000 BTU's per hour.
2. Assume a minimum delivery pressure of 10" w.c.
3. Assume a minimum inlet pressure of 10 PSIG.
4. For these conditions, refer to chart for the LV4403B Series, Second Stage Regulator, shown below.
5. Find the line on the chart corresponding to the anticipated inlet pressure.
6. Draw a vertical line upward from the point of assumed load (250,000 BTU's per hour) to intersect with the line corresponding to the lowest inlet pressure.
7. Read horizontally from the intersection of these lines to the delivery pressure at the left side of the chart. In this example the delivery pressure will read 10.6" w.c. Since the delivery pressure will be 10.6" w.c. at the maximum load condition and lowest anticipated inlet pressure, the regulator is sized properly for the demand.

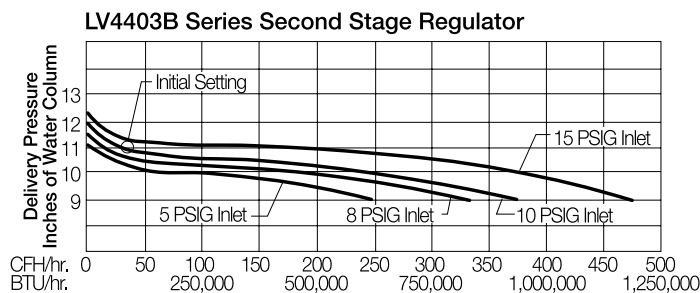

### RegO Service Valves for ASME and DOT Containers or Piping Systems

Designed especially for vapor or liquid withdrawal service on ASME and DOT containers or in fuel line applications.



9101R1

PART NUMBER	BONNET TYPE	CONTAINER CONNECTION	SERVICE CONNECTION	LIQUID LEVEL VENT VALVE
901C1	Standard	3/4" M. NGT	F.POL CGA 510	No
9101C1	Standard	3/4" M. NGT	F.POL CGA 510	No
9101DT11.1	Standard	3/4" M. NGT	F.POL CGA 510	Yes
9101DT11.7	Standard	3/4" M. NGT	F.POL CGA 510	Yes
9101R1	MultiBonnet	3/4" M. NGT	F.POL CGA 510	No
9101RT11.1	MultiBonnet	3/4" M. NGT	F.POL CGA 510	Yes
9101RT11.7	MultiBonnet	3/4" M. NGT	F.POL CGA 510	Yes

NOTE: Since these valves have no integral pressure relief, they must be used on a container with an independent relief device sufficient for that tank's capacity.

### RegO Service Valves for ASME Motor Fuel Containers

Designed specifically for vapor or liquid withdrawal service on ASME motor fuel containers.



901C5



9101H5



9101Y5H



9101H6

PART NUMBER	CONTAINER CONNECTION	SERVICE CONNECTION	LIQUID WITHDRAWAL CONNECTION	CLOSING FLOW (LP-GAS)		
				VAPOR		LIQUID GPM
				25 PSIG INLET (SCFH)	100 PSIG INLET (SCFH)	
901C5	3/4" M. NGT	F. POL CGA 510	NONE	550 ***	1050 ***	2.6 ***
9101H5*	3/4" M. NGT	3/8" SAE Flare	NONE	765 **	1300 **	3.6 **
9101H6*	3/4" M. NGT	3/8" SAE Flare	1/4" NPT	550 ****	1050 ****	2.6 ****
9101Y5H*	3/4" M. NGT	60° Angle 3/8" SAE Flare	NONE	550 **	1050 **	3.6 **

\* Heavy-duty models

\*\* Based on 3/8" O.D. pigtail, 20" long or less, connected to valve outlet. For greater lengths, the pigtail must have a larger O.D.

\*\*\* Same as (\*\*). In addition, 1/4" O.D. pigtails or POL connections for 1/4" O.D. should not be used with this valve.

\*\*\*\* Based on 3/8" O.D. pigtail; 20" long or less, connected to valve outlet. Also based on 1/4" pipe size dip tube, 42" long or less, attached to special inlet connection. For longer pigtail lengths, the diameter of the pigtail must be increased.

NOTE: These valves incorporate an excess flow valve.

## Cylinder Valves



Replacement parts for all valves, see Repair Parts, page 58.

### RegO Service Valves for DOT Forklift Containers

Designed specifically for vapor or liquid withdrawal service on DOT forklift containers. Valves with 1.5 GPM closing flow are for use in small and medium size lift truck applications, while those with 2.6 GPM closing flow are for large lift trucks and gantry crane type vehicles.

Replacement Handwheel - Part Number: 9101-31



9101P5  
9101P5HT



9101P6  
9101P6H

PART NUMBER	CONTAINER CONNECTION	SERVICE CONNECTION	LIQUID WITHDRAWAL CONNECTION	CLOSING FLOW (LP-GAS)			APPROXIMATE FILLING RATE LIQUID FLOW, GPM PRESSURE DROP ACROSS VALVE			
				VAPOR		LIQUID (GPM)	10 PSIG	25 PSIG	50 PSIG	100 PSIG
				25 PSIG INLET (SCFH)	100 PSIG INLET (SCFH)					
9101P5	3/4" M. NGT	3/8" MPT	NONE	430	900	1.5	5.0	7.6	10.7	14.9
9101P5H	3/4" M. NGT	3/8" MPT	NONE	550	1050	2.6	5.0	7.6	10.7	14.9
9101P6	3/4" M. NGT	3/8" MPT	1/4" NPT	430	900	1.5	4.5	7.2	10.3	14.8
9101P6H	3/4" M. NGT	3/8" MPT	1/4" NPT	550	1050	2.6	4.5	7.2	10.3	14.8

NOTE: These valves incorporate an excess flow valve.

### ACME Check Connectors for Forklifts



7141F

PART NUMBER	APPLICATION	INLET	OUTLET	PROTECTIVE CAP*	
				RUBBER	BRASS
7141M	Service Valve	3/8" F. NPT	1 1/4" M. ACME	7141M-40	7141FP
7141F	Fuel Line	1 1/4" F. ACME	1/4" F. NPT	—	—

\*Recommended to minimize foreign material entering valves which could result in leakage.

#### Repair Parts for 7141M



7141M

PART NUMBER	DESCRIPTION
7141M-3R	RegO Outer Flat Washer
MSW-4	Outer Washer Flat
2114A	Inner O-ring

For washers & o-rings, please see page 134 of the Washers and O-rings Section.

For washers & o-rings, please see page 134 of the Washers and O-rings Section.

**RegO Heavy-Duty Cylinder Valves for Vapor Withdrawal**

This heavy duty cylinder valve is designed for vapor withdrawal of DOT cylinders up to 100 lbs. propane capacity. It is used in domestic hook-ups and RVs and as a heavy cylinder valve.



9103-54

PART NUMBER	CONTAINER CONNECTION	SERVICE CONNECTION	FIXED LIQUID LEVEL VENT VALVE STYLE	DIP TUBE LENGTH W/DEFLECTOR	PRESSURE RELIEF VALVE SETTING	FOR USE IN CYLINDERS W/PROPANE CAPACITY UP TO:
9103D04.2	3/4" M. NGT	F. POL (CGA 510)	Knurled	4.2"	375 PSIG	100 lbs.
9103DT10.6	3/4" M. NGT	F. POL (CGA 510)	Knurled	10.6"	375 PSIG	100 lbs.
9103D11.6	3/4" M. NGT	F. POL (CGA 510)	Knurled	11.6"	375 PSIG	100 lbs.

**RegO Cylinder Valves for Liquid Withdrawal**

Equipped with excess flow valves and liquid withdrawal tubes.

PART NUMBER	CONTAINER CONNECTION	SERVICE CONNECTION	FIXED LIQUID LEVEL VENT VALVE STYLE	DIP TUBE LENGTH W/DEFLECTOR	PRESSURE RELIEF VALVE SETTING	FOR USE IN CYLINDERS W/PROPANE CAPACITY UP TO:
9107K8A	3/4" M. NGT	CGA 555	Knurled	11.6"	375 PSIG	100 lbs.



9107K8A

**Replacement Parts**

BLEEDER	REPLACEMENT HANDWHEEL	RELIEF VALVE CAP	REPLACEMENT THUMBSCREW
FOR 9103*	9107-31	9103-54	1931-24A
FOR 9106	9107-31	3100-54	1931-24A
FOR 9107	9107-31	3100-54	1931-24A

## Cylinder Valves



**Don't forget:**  
**R = MultiBonnet**  
**T = Thread Compound**

### RegO Cylinder Valve for RV and Small ASME System Vapor Withdrawal

Designed especially for vapor withdrawal service in small ASME containers with surface area up to 23.8 square feet.

UL flow capacity is 645 CFM/air, per NFPA 58.

PART NUMBER	CONTAINER CONNECTION	SERVICE CONNECTION	FIXED LIQUID LEVEL VENT VALVE STYLE	PRESSURE RELIEF VALVE SETTING
9106C0	3/4" M. NGT	F. POL	NONE	312 PSIG



### Compact Cylinder Valves with OPD and QCC Type 1

These valves are designed for use on DOT LP gas cylinders up to 40 lbs.



DC-QCC1

#### Repair Parts for Compact Cylinder Valves

PART NUMBER	DESCRIPTION
3125-40P	Relief Cap
DC-QCC1	Dust Cover



3125-40P

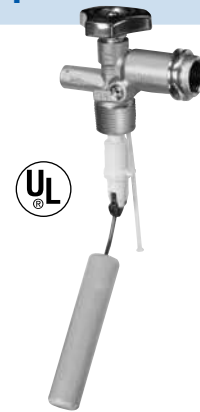

PART NUMBER	DIP TUBE LENGTH W/ DEFLECTOR	FOR USE ON DOT CYLINDERS UP TO:	CONTAINER CONNECTION	SERVICE CONNECTION TYPE	SERVICE CONNECTION DESCRIPTION	FIXED LIQUID LEVEL VENT VALVE STYLE	ACCESSORIES RELIEF VALVE SETTING
MSCP-VQCC-B.7	3.0"	5 lbs.	3/4" M. NGT	Type 1	1 15/16" M. ACME and F. POL CGA 791	Slotted	375 PSIG
MSCP-VQCC-B	4.0"	20 lbs.	3/4" M. NGT	Type 1	1 15/16" M. ACME and F. POL CGA 791	Slotted	375 PSIG
MSCP-VQCCB-2	4.8"	30 lbs.	3/4" M. NGT	Type 1	1 15/16" M. ACME and F. POL CGA 791	Slotted	375 PSIG
MSCP-VQCC-B.3	6.5"	40 lbs.	3/4" M. NGT	Type 1	1 15/16" M. ACME and F. POL CGA 791	Slotted	375 PSIG

### RegO DOT Multivalve for Vapor Withdrawal



These Multivalves permit vapor withdrawal from DOT cylinders with up to 200 lbs. propane capacity.

PART NUMBER	CONTAINER CONNECTION	SERVICE CONNECTION	FILLING CONNECTION	FIXED LIQUID LEVEL VENT VALVE STYLE	DIP TUBE LENGTH W/DEFLECTOR	PRESSURE RELIEF VALVE SETTING
8555RT10.6	3/4" M. NGT	F. POL	1 3/4" M. ACME (CGA 510)	Knurled	10.6"	375 PSIG
8555DT10.6	3/4" M. NGT	F. POL	1 3/4" M. ACME (CGA 510)	Knurled	10.6"	375 PSIG
8555RT11.6	3/4" M. NGT	F. POL	1 3/4" M. ACME (CGA 510)	Knurled	11.6"	375 PSIG
8555DT11.6	3/4" M. NGT	F. POL	1 3/4" M. ACME (CGA 510)	Knurled	11.6"	375 PSIG
6555R11.6	3/4" M. NGT	F. POL	1 3/4" M. ACME	Knurled	11.6"	250 PSIG

#### Repair Parts

PART NUMBER	DESCRIPTION
3100-54	Relief Valve Cap
MSCP-M3274-9P	Fill Valve Cap
903-31	Replacement Handwheel
10104-50	Bonnet Assembly Kits - Mug
6542 B-80	Bonnet Assembly Kits - Filler



MSCP-M3274-9P

### RegO DOT Multivalve for Liquid Withdrawal

This Multivalve permits liquid withdrawal from DOT cylinders with up to 100 lbs. propane capacity. Equipped with an excess flow valve and liquid withdrawal tube.

#### Repair Parts

PART NUMBER	DESCRIPTION
3100-54	Relief Valve Cap
MSCP-M3274-9P	Fill Valve Cap
9107-31	Replacement Handwheel
A948	Adapter Female CGA555 to F. POL



3100-54



9107-31



A948



N86



NP210



PART NUMBER	CONTAINER CONNECTION	SERVICE CONNECTION	FILLING CONNECTION	FIXED LIQUID LEVEL VENT VALVE STYLE	DIP TUBE LENGTH W/ DEFLECTOR	LIQUID WITHDRAWAL TUBE LENGTH	PRESSURE RELIEF VALVE SETTING	FOR USE IN CYLINDERS W/PROPANE CAPACITY UP TO:	LIQUID CLOSING FLOW (LP-GAS)
8555DL11.6	3/4" M. NGT	CGA 555	1 3/4" M. ACME	Knurled	11.6"	44"	375 PSIG	100 lbs.	1.7 GPM

## Multivalves



### RegO DOT and ASME Multivalve for Vapor Withdrawal

These Multivalves permit vapor withdrawal from ASME containers up to 50 sq. ft. surface area and DOT containers up to 420 lbs. propane capacity.

PART NUMBER	APPLICATION	CONTAINER CONNECTION	SERVICE CONNECTION	FILLING CONNECTION	FIXED LIQUID LEVEL VENT VALVE STYLE	DIP TUBE LENGTH W/ DEFLECTOR	PRESSURE RELIEF VALVE SETTING	FOR USE IN DOT CYLINDERS W/PROPANE CAPACITY UP TO:**	FOR USE IN DOT CYLINDERS W/SURFACE AREA UP TO:***
6532R12.0	ASME*	3/4" M. NGT	F. POL (CGA 510)	1 3/4" M. ACME	Knurled	12.0"	250 PSIG	-	43 sq. ft.
6542RT12.0	ASME*	1" M. NGT	F. POL (CGA 510)	1 3/4" M. ACME	Knurled	12.0"	250 PSIG	-	53 sq. ft.
6533R10.5	DOT	3/4" M. NGT	F. POL (CGA 510)	1 3/4" M. ACME	Knurled	10.5"	375 PSIG	420 lbs. Propane	-
6533AT11.7	DOT	3/4" M. NGT	F. POL (CGA 510)	1 3/4" M. ACME	Knurled	11.7"	375 PSIG	420 lbs. Propane	-
6533RT11.7	DOT	3/4" M. NGT	F. POL (CGA 510)	1 3/4" M. ACME	Knurled	11.7"	375 PSIG	420 lbs. Propane	-
6543AT11.1	DOT	1" M. NGT	F. POL (CGA 510)	1 3/4" M. ACME	Knurled	11.1"	375 PSIG	420 lbs. Propane	-
6543RT11.1	DOT	1" M. NGT	F. POL (CGA 510)	1 3/4" M. ACME	Knurled	11.1"	375 PSIG	420 lbs. Propane	-
6543AT11.7	DOT	1" M. NGT	F. POL (CGA 510)	1 3/4" M. ACME	Knurled	11.7"	375 PSIG	420 lbs. Propane	-
6543RT11.7	DOT	1" M. NGT	F. POL (CGA 510)	1 3/4" M. ACME	Knurled	11.7"	375 PSIG	420 lbs. Propane	-

\* UL rated flow capacities are: 6532A12.0-1180 SCFM/air, 6542A12.0-1530 SCFM/air.

\*\* Per CGA Pamphlet S-1.1.

\*\*\* From NFPA, Appendix D.

### Repair Parts

PART NUMBER	DESCRIPTION
3131-54	Relief Valve Cap
MSCP-M3274-9P	Fill Valve Cap
9107-31	Replacement Handwheel

### RegO ASME Multivalve for Vapor Withdrawal

These multivalves provide vapor withdrawal and filling of ASME containers. A separate pressure relief valve is required in addition to this valve. The MultiBonnet is standard on this valve.

PART NUMBER	CONTAINER CONNECTION	SERVICE CONNECTION	FILLING CONNECTION	VAPOR EQUALIZING CONNECTION		LIQUID LEVEL VENT VALVE STYLE	FIXED DIP TUBE* LENGTH	FOR USE IN CONTAINERS W/SURFACE AREA UP TO:
				CONNECTION SIZE	UL LISTED CLOSING FLOW			
8593AL16.0	1 1/2" M. NGT	F. POL (CGA 510)	1 3/4" M. ACME	1 3/4" M. ACME	4200 CFH at PSIG	Knurled	16"	**

\* Dip tube not installed, may be cut by customer to desired length.

\*\* Since these multivalves have no integral pressure relief valves, they can be used on any ASME container with an independent relief device sufficient for that tank's capacity.

### Repair Parts

PART NUMBER	DESCRIPTION
3144-9P	Vapor Equalization Cap
MSCP-M3274-9P	Fill Valve Cap
9107-31	Replacement Handwheel





### RegO ASME Multivalve for Vapor Withdrawal

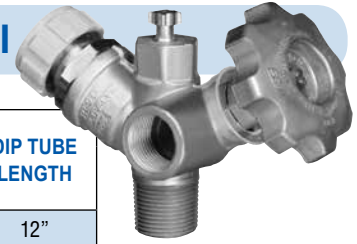

PART NUMBER	CONTAINER CONNECTION	SERVICE CONNECTION	VAPOR EQUALIZING CONNECTION		FIXED LIQUID LEVEL VENT VALVE STYLE	DIP TUBE LENGTH
			CONNECTION SIZE	UL LISTED CLOSING FLOW		
7556R12.0*	3/4" M. NGT	F. POL (CGA 510)	1 1/4" M. ACME	4200 CFH @ 100 PSIG	Knurled	12"

\* MultiBonnet Design

New style 1/8" F.NPT pressure test port with the service valve closed the pressure test port will be isolated from the container. This will allow a high pressure leak test be conducted without disconnecting the pigtail from the service valve.

This compact multivalve is especially suited for vapor withdrawal of ASME containers where compact groupings of components are necessary. Separate filler valves and pressure relief valves are required.

#### Replacement Parts

PART NUMBER	DESCRIPTION
3144-9P	Vapor Equalization Cap
9107-31	Replacement Handwheel

### RegO External Relief Valves for ASME Containers and Bulk Plant Installations

Designed for use as a primary relief valve on ASME above ground and underground containers, bulk plant installations and skid tanks. The 3131 Series may also be used as a primary or secondary relief valve on DOT cylinders, or as a hydrostatic relief valve.



AA3135



3135



W3132G

PART NUMBER	START TO DISCHARGE SETTING PSIG	CONTAINER CONNECTION M. NPT	OVERALL HEIGHT (APPROX.)	WRENCH HEX SECTION	FLOW CAPACITY SCFM/AIR		SUITABLE FOR TANKS W. SURFACE AREA UP TO: (E)	ACCESSORIES			
					UL AT 120% OF SET PRESSURE	ASME AT 120% OF SET PRESSURE		PROTECTIVE CAP	PIPEAWAY ADAPTER PART NUMBER	OUTLET SIZE	WEEP HOLE DEFLECTOR
3131G	250	3/4"	3 7/16"	1 3/4"	2060	1939	85 sq. ft.	3131-40 (g)	-	-	-
W3132G	250	1"	6 1/32"	2 3/8"	3340	-	154 sq. ft.	3132-54 (g)	3132-10	1 1/4" F. NPT	-
3132G	250	1 1/4"	6 1/32"	2 3/8"	4130	-	200 sq. ft.	3132-54 (g)	-	-	-
T3132G	250	1 1/4"	6 1/32"	2 3/8"	3790	-	180 sq. ft.	3132-54 (g)	3132-10	1 1/4" F. NPT	-
MV3132G	250	1 1/4"	6 1/32"	2 3/8"	3995	-	190 sq. ft.	3132-54 (g)	-	-	-
3135G	250	1 1/4"	5 21/32"	2 11/16"	5770	-	300 sq. ft.	3132-54 (g)	3135-10	2" F. NPT	-
3133G	250	1 1/2"	5 15/16"	3 1/8"	6080	-	320 sq. ft.	3133-40 (g)	3133-10	2" F. NPT	-
A3149G	250	2 1/2"	10 1/2"	4 1/8"	10390	9153	613 sq. ft.	3149-40	(h)	(h)	Included (j)

Anhydrous Ammonia Parts available upon request

"A" prefix – Products with this prefix are suitable for LP-gas or NH<sub>3</sub> service (i.e., contain no brass parts).

- (a) Flow rates shown are for bare relief valves. Adapters and pipeaways will reduce flow.
- (b) Not UL or ASME rated. .059 square inch effective area.
- (c) Not UL or ASME rated. ECII® rated at 120% of set pressure.
- (d) Rated at 110% of set pressure.
- (e) Per NFPA Pamphlet #58, Appendix D. Area shown is for UL or ASME flow rating —whichever is larger.
- (f) Per ANSI K61.1-1972, Appendix A.
- (g) Cap supplied with chain.
- (h) Outlet 31/2-8N (F) thread, will accept 3" M. NPT pipe thread.
- (j) Weep hole deflector is Part No. A3134-11B.



All Trinity Tanks come with RegO valves. You'll find the G8475 on all Trinity UG Tanks.

### RegO Low Emissions Underground Multivalve

These Multivalves are designed for use in single opening ASME containers equipped with a 2 1/2" M. NPT riser.



#### Features

- Combines low emission double back check filler valve, vapor equalizing valve, pressure relief valve, service valve, fixed liquid level gauge, "junior" sized float gauge flange opening and a plugged pressure gauge opening.
- Double back check filler valve is low emission, 2.13cc at disconnection no reduction in fill rates.
- Service valve features a Multibonnet® stem assembly that allows for repair without evacuating gas from the container.
- Designed for installation of a 1/8" FNPT pressure gauge or pressure gauge connection like the Presto-Tap®.

#### Materials

- Body ..... Forged Brass
- Hand-wheel ..... Aluminum
- Valve Stems ..... Brass
- O-rings..... Resilient Rubber
- Seat Disc (shutoff) ..... Nylon
- Seat Disc (other) ..... Resilient Rubber
- Relief Spring ..... Stainless Stain

#### Replacement Parts

PART NUMBER	DESCRIPTION
3131-40	Relief Valve Cap
MSCP-M3274-9P	Fill Valve Cap
3144-9P	Vapor Equalization Cap
8475-X30.0	Diptube
9107-31	Replacement Handwheel

PART NUMBER	CONTAINER CONNECTION	SERVICE CONNECTION	FILLING CONNECTION	VAPOR EQUALIZING CONNECTION		FLOAT GAUGE FLANGE OPENING	FIXED LIQUID LEVEL VENT VALVE STYLE	DIP TUBE LENGTH	PRESSURE RELIEF VALVE SETTING	UL LISTED RELIEF VALVE CAPACITY	FOR USE IN CONTAINERS W/SURFACE AREA UP TO:
				CONNECTION SIZE	UL LISTED CLOSING FLOW						
G8475RL	2 1/2" F. NPT	F. POL (CGA 510)	1 3/4" M. ACME	1 1/4" M. ACME	4200 CFH @ 100 PSIG	Fits "JUNIOR" Size	Knurled	30"*	250 PSIG	2020 SCFM/air	83 sq. ft. Above ground 276 sq. ft. Underground
G8475RLW	2 1/2" F. NPT	F. POL (CGA 510)	1 3/4" M. ACME	1 1/4" M. ACME	4200 CFH @ 100 PSIG	Fits "JUNIOR" Size	Knurled	30"*	250 PSIG	3995 SCFM/air	192 sq. ft. Above ground 639 sq. ft. Underground

\* Dip tube not installed, may be cut by customer to desired length.

#### Trinity Underground Tanks

TANK SIZE	SQUIBB TAYLOR JR 4 BOLT		ROCHESTER JR 4 BOLT		REPLACEMENT DIAL	
	14" RISER	28" RISER	14" RISER	28" RISER	SQUIBB TAYLOR	ROCHESTER
120 WG	JB213B	JB340A	6281-0490	6281-0491	2700CV	5-01813
250 WG	JB251A	JB376A	6281-0534	6281-0535	2700CV	5-01813
320 WG	JB251A	JB376A	6281-0534	6281-0535	2700CV	5-01813
500 WG	JB277A	JB404D	6281-0427	6281-0426	2700CV	5-01813
1000 WG	JB297A	JB424C	6281-0524	6281-0418	2700CV	5-01813
2000 WG	-	JB450D	-	-	2700CV	5-01813

### RegO Fully Internal Pressure Relief Valve for DOT Forklift Cylinder

Designed for use as a primary relief valve on forklift cylinders, the 8545AK reduces the possibility of improper functioning of the relief mechanism due to foreign material build up.

PART NUMBER	CONTAINER TYPE	START TO DISCHARGE SETTING (PSIG)	CONTAINER CONNECTION M. NPT	FLOW CAPACITY SCFM/AIR** (ECII® RATED AT 480 PSIG)
8545AKT	DOT	375	3/4"	400*

\* Classified by U.L. in accordance with Compressed Gas Association Pamphlet S-1.1 Pressure Device Standards for Cylinders. Meets requirements for use on DOT containers with 262 pounds or less weight of water or 109 pounds or less of LP-Gas.

\*\* Flow rates are shown for bare relief valves. Adapters and pipeways will reduce flow as discussed in forewording information.



8545AKT

#### Accessories

PROTECTIVE CAP	45° ELBOW	90° ELBOW
7545-40	7545-14A	7545-12

\*\*\* Order protective cap #8545-41 or 7545-40.



7545-14A



7545-12

### RegO External Hydrostatic Relief Valves

Designed especially for the protection of piping and shut-off valves where there is a possibility of trapping liquid LP-gas or anhydrous ammonia. They may be installed in pipelines and hoses located between shut-off valves or in the side boss of RegO shut-off valves.



3127G



SS8022G

PART NUMBER	START TO DISCHARGE SETTING (PSIG)	VALVE BODY MATERIAL	CONTAINER CONNECTION M. NPT	HEIGHT (APPROX.)	WRENCH HEX SECTION	ACCESSORIES	
						PROTECTIVE CAP	PIEAWAY ADAPTER OR THREADS
SS8001G	250	Stainless Steel	1/4"	7/8"	11/16"	8001-54*	-
SS8021G	250	Stainless Steel	1/4"	1 3/8"	11/16"	8001-54	1/4" NPSM Thrds
SS8022G	250	Stainless Steel	1/2"	1 3/8"	7/8"	8002-54*	3/8" NPT Thrds
3127G	250	Brass	1/4"	1 31/32"	7/8"	9103-54*	-
3129G	250	Brass	1/2"	2 19/32"	1 1/8"	3129-40P*	3129-10**
3127H	275	Brass	1/4"	1 31/32"	7/8"	9103-54*	-
3129P	300	Brass	1/2"	2 19/32"	1 1/8"	3129-40P*	3129-10**
3127J	350	Brass	1/4"	1 31/32"	7/8"	9103-54*	-
3129J	350	Brass	1/2"	2 19/32"	1 1/8"	3129-40P*	3129-10**
SS8001J	350	Stainless Steel	1/4"	7/8"	11/16"	8001-54	-
SS8021J	350	Stainless Steel	1/4"	1 3/8"	11/16"	8001-54	1/4" NPSM Thrds
SS8022J	350	Stainless Steel	1/2"	1 3/8"	7/8"	8002-54*	3/8" NPT Thrds
3127K	375	Brass	1/4"	1 31/32"	7/8"	9103-54*	-
3129K	375	Brass	1/2"	2 19/32"	1 1/8"	3129-40P*	3129-10**
3125L	400	Brass	1/4"	1 9/16"	5/8"	9103-54*	-
3127L	400	Brass	1/4"	1 31/32"	7/8"	9103-54*	-
3129L	400	Brass	1/2"	2 19/32"	1 1/8"	3129-40P*	3129-10**
SS8021L	400	Stainless Steel	1/4"	1 3/8"	11/16"	8001-54	1/4" NPSM Thrds
SS8022L	400	Stainless Steel	1/2"	1 3/8"	7/8"	8002-54*	3/8" NPT Thrds
3127U	450	Brass	1/4"	1 31/32"	7/8"	9103-54*	-
3129U	450	Brass	1/2"	2 19/32"	1 1/8"	3129-40P*	3129-10**
SS8001U	450	Stainless Steel	1/4"	7/8"	11/16"	8001-54*	-
SS8021U	450	Stainless Steel	1/4"	1 3/8"	11/16"	8001-54	1/4" NPSM Thrds
SS8022U	450	Stainless Steel	1/2"	1 3/8"	7/8"	8002-54	3/8" NPT Thrds

\* Included

\*\* 1/2" F.NPT outlet connection

## Relief Valves



All RegO relief valves are tested before they leave the factory to assure reliability.

### RegO Vapor Relief Valves



3139

Designed for use as a relief valve on first stage regulators with a rated capacity of more than 500,000 BTU/hour as per NFPA 58 2.5.7.5.

PART NUMBER	RELIEF VALVE SETTING	REGULATOR SET PRESSURE	CONNECTION SIZE	HEIGHT	WIDTH
3139-18	18 PSIG	10 PSIG	1/4" MNPT	2 27/32"	1 1/16"
3139-26	26 PSIG	15 PSIG	1/4" MNPT	2 27/32"	1 1/16"
3139-38	38 PSIG	20 PSIG	1/4" MNPT	2 27/32"	1 1/16"



3139 in use

#### Accessories

PART NUMBER	DESCRIPTION
9103-54	Relief Valve Cap

### RegO Internal Relief Valves for Transports and Delivery Trucks



A8434G

#### Fully Internal "Pop-Action" Pressure Relief Valves for Transports and Delivery Trucks

Designed specifically for use as a primary relief valve with ASME transports and delivery trucks with 2" and 3" NPT couplings. All stainless steel construction.

PART NUMBER	START TO DISCHARGE SETTING (PSIG)	CONTAINER CONNECTION M. NPT	FLOW CAPACITY SCFM/AIR		SUITABLE FOR TANKS WITH SURFACE AREA UP TO (SQ. FT.)	PROTECTIVE CAP (INCLUDED)
			UL (AT 120% OF SET PRESSURE)	ASME (AT 120% OF SET PRESSURE)		
A8434G	250	2"	3700	3456	175 SQ FT	A8434-11B
A8436G	250	3"	10210	9598	602 SQ FT	A8436-11B

#### Removal Tools

Assists with removing fully internal relief valves.

Part Number: A8434-40 for use on A8434G

Part Number: A8436-40 for use on A8436G

### RegO Internal Relief Valves for ASME Containers



8685G

#### Semi-internal "Pop Action" Pressure Relief Valves

Designed for use as a primary relief valve on ASME containers such as 250, 500, and 1,000 gallon tanks.

PART NUMBER	START TO DISCHARGE SETTING (PSIG)	CONTAINER CONNECTION M. NPT	FLOW CAPACITY SCFM/AIR		SUITABLE FOR TANKS WITH SURFACE AREA UP TO (SQ. FT.)	PROTECTIVE CAP (INCLUDED)
			UL (AT 120% OF SET PRESSURE)	ASME (AT 120% OF SET PRESSURE)		
7583G	250	3/4"	1980	1806	80	7583-40
8684G	250	1"	2620	2565	113	8684-40
8685G	250	1 1/4"	4385	4035	212	7585-40

### RegO Internal Relief Valves for Large Storage Containers



#### Semi-internal "Pop Action" Pressure Relief Valves

Designed especially for use as a primary relief valve on large stationary storage containers, these low profile relief valves are generally mounted in half couplings.

#### Accessories

PROTECTIVE CAP	PIPEAWAY ADAPTER
7534-40	7534-20***

\*\*\* 3" F. NPT outlet connection.

PART NUMBER	START TO DISCHARGE SETTING (PSIG)	CONTAINER CONNECTION M. NPT	FLOW CAPACITY SCFM/AIR		SUITABLE FOR TANKS WITH SURFACE AREA UP TO:**
			UL (AT 120% OF SET PRESSURE)	ASME (AT 120% OF SET PRESSURE)	
7534G	250	2"	11,675	10,422	708 Sq. Ft.

\* Flow rates shown are for bare relief valves. Adapters and pipeaways will reduce flow as discussed in the forewording information.  
 \*\* Per NFPA Pamphlet #58, Appendix D. Area shown is for UL or ASME—whichever is larger.

### RegO Relief Valves for Motor Fuel Containers

#### Fully Internal "Pop Action"

8543 Series relief valves are designed for use as a primary relief valve in larger ASME motor fuel containers such as on buses, trucks and construction equipment.

8544 Series relief valves are designed for use as a primary relief valve in smaller ASME and DOT motor fuel containers such as on tractors, lift trucks, cars and taxicabs.

PART NUMBER	CONTAINER TYPE	START TO DISCHARGE SETTING (PSIG)	CONTAINER CONNECTION M. NPT	OVERALL HEIGHT (APPROX)	HEIGHT ABOVE COUPLING (APPROX.)	HEX WRENCHING SECTION	FLOW CAPACITY SCFM/AIR****		PROTECTIVE CAP (INCLUDED)
							UL (AT 120% OF SET PRESSURE)	ASME (AT 120% OF SET PRESSURE)	
8544GT	ASME	250	1"	5 7/16"	7/8"	1 5/16"	1020	936	7544-41
8544T	ASME	312	1"	5 7/16"	7/8"	1 5/16"	1282	1158	7544-41
8544KT	DOT/ASME	375	1"	5 7/16"	7/8"	1 5/16"	1545***	-	7544-41

\* 1" M. NPT outlet connection.  
 \*\* 1 1/4" M. NPT outlet connection.  
 \*\*\* Rating also applies to DOT requirements.  
 \*\*\*\* Flow rates shown are for bare relief valves. Adapters and pipeaway will reduce flow.

#### Accessories

PIPEAWAY ADAPTER
7544-11A* for 8544G
7543-10** for 8543G
7544-11A* for 8544T
7543-10** for 8543T
7544-11A* for 8544K



7543-10



7544-11A



### Relief Valve Bonnets

An inexpensive, expendable relief valve cover that fits virtually all popular sizes. Meets NFPA requirements. Self venting and weather resistant.

#### Universal Relief Valve Cover

PART NUMBER	SIZE
85	1/2" - 3/4"
85A	3/4" - 1 1/4"

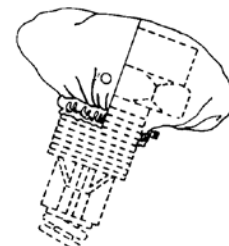

## Relief Valves

### BelGAS 627 Propane Regulator



BELGAS PART #	VERSION	CAPACITY BTU/HR	INLET/OUTLET	ORIFICE	OUTLET PRESSURE PSIG	SET POINT PSIG	MAOP PSIG
			CONN'S				
L627-06-020-00-4-010	Non-Relief	3,940,000	3/4" FNPT	1/4"	5-20	10	250
L627-06-020-00-6-010	Non-Relief	6,080,000	3/4" FNPT	3/8"	5-20	10	250
L627-06-020-00-8-010	Non-Relief	10,755,000	3/4" FNPT	1/2"	5-20	10	250
L627-08-020-00-6-010	Non-Relief	7,490,000	1" FNPT	3/8"	5-20	10	250
L627-08-020-00-8-010	Non-Relief	10,773,000	1" FNPT	1/2"	5-20	10	250
L627-16-020-00-6-010	Non-Relief	5,783,000	2" FNPT	3/8"	5-20	10	250
L627-16-020-00-8-010	Non-Relief	10,263,000	2" FNPT	1/2"	5-20	10	250

### RegO Duo-port Pressure Relief Valve Manifolds for Small Storage Containers

Designed especially for use as a primary relief device on smaller stationary storage containers up to 1200 gallons water capacity, with 2" NPT threaded couplings.



PART NUMBER	START TO DISCHARGE SETTING (PSIG)	APPLICATION		CONTAINER FLANGE CONNECTION	RELIEF VALVE INCLUDED				FLOW CAPACITY SCFM/AIR** UL (AT 120% OF SET PRESSURE)
		LP-GAS	NH3		QUANTITY	PART NUMBER	INLET CONNECTION M. NPT	ACCESSORY PIPEAWAY ADAPTERS*	
8542G	250	Yes	No	2"	2	3135MG	1 1/4"	3135-10	5250 (1)

\* 2" F. NPT Outlet Connection

\*\* Flow Rating based on number of relief valves indicated in parenthesis.

Relief Valve Cap - Part Number: 3135-54

### RegO Multiport Pressure Relief Valve Manifold Assemblies for Large Storage Containers



Designed especially for use as a primary relief device on large stationary pressurized storage containers with flanged openings. These manifolds incorporate an additional relief valve, not included in the flow rating, allowing for servicing or replacement of any one of the relief valves without evacuating the container. The handwheel on the manifold selectively closes off the entrance port to the relief valve being removed while the remaining relief valves provide protection for the container and its contents. All manifold flow ratings are based on flow through the relief valves after one has been removed for service or replacement.

PART NUMBER	START TO DISCHARGE SETTING (PSIG)	APPLICATION		CONTAINER FLANGE CONNECTION	RELIEF VALVE				FLOW CAPACITY SCFM/AIR** AT 120% OF SET PRESSURE	
		LP-GAS	NH3		QUANTITY	PART NUMBER	INLET CONNECTION M. NPT	ACCESSORIES PIPEAWAY ADAPTERS	UL RATING	ASME RATING
A8563AG	250	Yes	Yes	3"-300#*	3	A3149G	2 1/2"	****	N/A	18,300 (2)
A8564AG	250	Yes	Yes	3"-300#*	4	A3149G	2 1/2"	****	N/A	27,400 (3)
A8573AG	250	Yes	Yes	4"-300#	3	A3149G	2 1/2"	****	N/A	18,300 (2)
A8574AG	250	Yes	Yes	4"-300#	4	A3149G	2 1/2"	****	N/A	27,400 (3)

\* For use with modified 300# ANSI flange with 4" port.

\*\* Flow rating based on number of relief valves indicated in parenthesis . Flow rates shown are for bare relief valves. Adapters and pipeways will reduce flow rates as discussed in forewording information.

\*\*\* 2" F. NPT outlet connection.

\*\*\*\* Outlet 31/2 (F) thread, will accept 3" M. NPT pipe thread.

\*1 Special order, non-stock item.

Relief Valve Cap - Part Number: 3149-40

## Relief Valves



**The RegO Multiport makes changing storage tank relief valves a snap. No need to empty the tank!**

### Multiport Manifolds for Storage Containers

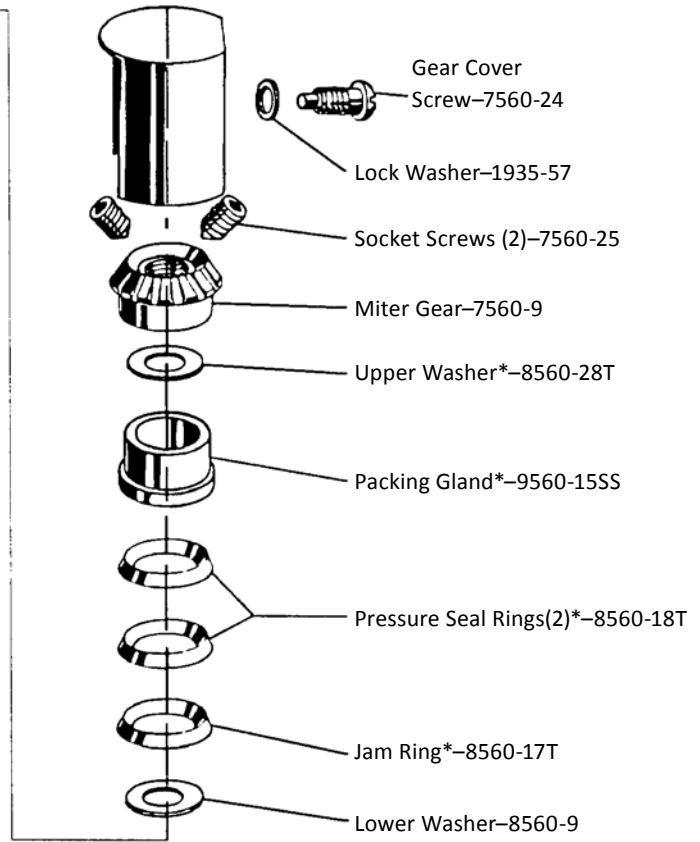
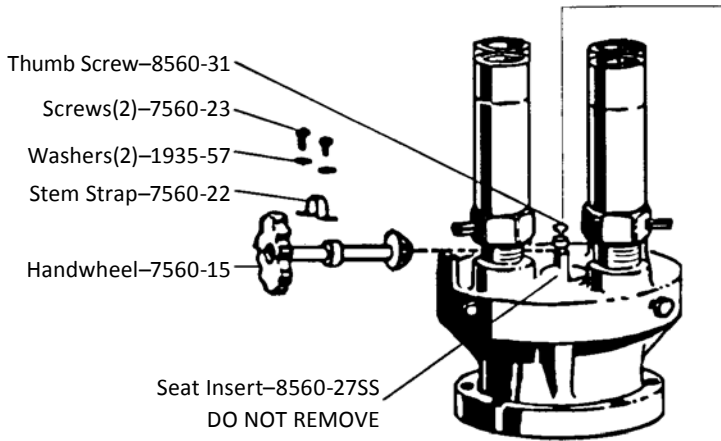

\*Denotes parts that must be ordered for replacement.

### Weather Caps

Provides protection of vertical relief valve riser pipes against rain and foreign material.



PART NUMBER	PIPE SIZE
P770-1-1/8	3/4"
P770-2-3/8	2"
P770-3-1/2	3"
P770-4-1/2	4"

**Weather caps and vent stacks, see page 119 of Plant Equipment.**

### Multi-port Flange Repair Parts

PART NUMBER	CONSISTS OF:	FOR USE WITH:	FOR CONNECTION TO:	NUMBER REQUIRED
7560-55	1-Bolt Stud and Nut	All ECII Multiports	Modified 3"-300# and 4"-ASA 300# Welding Neck Flange	8
7560-56	1-Bolt Stud and Nut	All ECII Multiports	Manifold Cover Plate	8
A3134-11B	Weep Hole Deflector	-	-	-
8560-26TP	Bleeder Valve	-	-	-



**RegO Flange Seal Globe and Angle Valves for Bulk Storage Containers, Filling Hoses and Plant Piping**



A7704P

A7706 P

Designed to assure positive shut-off and long maintenance-free service life in liquid or vapor service. Ideally suited for use on cylinder charging manifolds, truck filling hoses, bulk storage containers and plant piping.

PART NUMBER	CONFIGURATION	FPT SIZE	PRESSURE DROP (CV) (GPM/PROPANE)
A7704P	Globe	1/2"	7.3
A7705P	Globe	3/4"	11.5
A7704LP	Angle	1/2"	12.3
A7706P	Angle	3/4"	17.7

**RegO "V"-ring Globe and Angle Valves for Bulk Storage Containers, Transports, Bobtails and Plant Piping**



A7505AP

A7513AP

Specifically designed to assure positive shut-off and long maintenance-free service life in liquid or vapor service on bulk storage containers, transports, bobtails, cylinder filling plants and plant piping.

PART NUMBER	CONFIGURATION	INLET AND OUTLET CONNECTION	PORT DIAMETER
A7505AP	Globe	3/4" FNPT	3/4"
A7507AP	Globe	1" FNPT	1"
A7509BP	Globe	1 1/4" FNPT	1 1/4"
A7511AP	Globe	1 1/2" FNPT	1 1/2"
A7511FP	Globe	1 1/2" Flange	1 1/2"
A7513AP	Globe	2" FNPT	2"
A7513FP	Globe	2" Flange	2"
A7517AP	Globe	3" FNPT	3 1/8"
A7517FP	Globe	3" Flange	3 1/8"
A7506AP	Angle	3/4 " FNPT	3/4"
A7508AP	Angle	1" FNPT	1"
A7510BP	Angle	1 1/4" FNPT	1 1/4"
A7512AP	Angle	1 1/2" FNPT	1 1/2"
A7514AP	Angle	2" FNPT	2"
A7514FP	Angle	2" Flange	2"
A7518AP	Angle	3" FNPT	3 1/8"
A7518FP	Angle	3" Flange	3 1/8"



A7514AP



A7517AP

See page 61 for Bonnet Assemble Repair Kits

Teflon seal discs available on request for most models.

# VALVES

## Ball Valves



We've got a globe, angle or ball valve to fit your application and budget.

### Ball Valves



FLARE X FLARE



T-HANDLE

LEGEND PART NO.	INLET	OUTLET
102-312	3/8 M. Flare	3/8 M. Flare
102-313	1/2 M. Flare	1/2 M. Flare
102-314	5/8 M. Flare	5/8 M. Flare

T-HANDLES*		
LEGEND PART NO.	INLET	OUTLET
101-602	3/8 M. Flare	3/8 M. Flare
101-603	1/2 M. Flare	1/2 M. Flare
101-402	3/8 FPT	3/8 FPT
101-403	1/2 FPT	1/2 FPT
101-404	3/4 FPT	3/4 FPT



FPT X FLARE

MPT/FPT X FLARE		
LEGEND PART NO.	INLET	OUTLET
102-212	1/2 MPT	3/8 M. Flare
102-213	1/2 MPT	1/2 M. Flare
102-112	1/2 FPT	3/8 M. Flare
102-113	1/2 FPT	1/2 M. Flare
102-118	3/4 FPT	1/2 M. Flare
102-114	3/4 FPT	5/8 M. v
102-102	3/8 FPT	3/8 FPT
102-103	1/2 FPT	1/2 FPT
102-104	3/4 FPT	3/4 FPT



FLARE X FLARE

SIDE TAPS		
LEGEND PART NO.	INLET	OUTLET
102-522	3/8 M. Flare	3/8 M. Flare
102-523	1/2 M. Flare	1/2 M. Flare
102-524*	5/8 M. Flare	5/8 M. Flare
102-513	1/2 FPT	1/2 FPT
102-514	3/4 FPT	3/4 FPT
102-402*	3/8 M. Flare	3/8 M. Flare
102-403*	1/2 M. Flare	1/2 M. Flare

### Jomar Ball Valves



101-602



102-512



102-402



102-103

LEGEND PART NO.	INLET	OUTLET
100-299	1/4" FPT	1/4" MPT
100-701	1/4" FPT	1/4" FPT
100-703	1/2" FPT	1/2" FPT
100-704	3/4" FPT	3/4" FPT
100-996	1 1/4" FPT	1 1/4" FPT
100-998	2" FPT	2" FPT
101-402	3/8" FPT	3/8" FPT
101-403	1/2" FPT	1/2" FPT
101-403DU	1/2" NPT	1/2" NPT
101-404	3/4" FPT	3/4" FPT
101-404DU	3/4" NPT	3/4" NPT
101-503	1/2" FPT	1/2" MFL
101-513DU	1/2" NPT	1/2" FLARE
101-602	3/8" MFL	3/8" MFL
101-603	1/2" MFL	1/2" MFL
101-998	2" SOLDER	2" SOLDER
102-303	1/2" FPT	1/2" FPT T-HAN
102-304	3/4" FPT	3/4" FPT T-HAN
102-402	3/8" MFL	3/8" MFL T-HAND W/ TAP
102-403	1/2" MFL	1/2" MFL T-HAND W/ TAP
102-512	1/2" FPT	3/8" MFL
102-524	5/8" MFL	5/8" MFL
241-004D*	3/4" FPT	3/4" FPT

\* with insulated tail piece

### Large Port Ball Valves

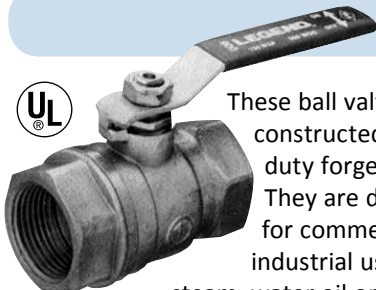

These ball valves are constructed of heavy duty forged brass. They are designed for commercial and industrial use on steam, water oil or gas. They are UL listed for LP gas service.

#### Pressure Rating

1/4" - 3/4" 600lbs. W.O.G. Non-Shock  
1" - 2" 500lbs. W.O.G. Non-Shock

LEGEND PART NO.	INLET	OUTLET
101-101*	1/4"	1/4"
101-102	3/8"	3/8"
101-103	1/2"	1/2"
101-544	3/4"	3/4"
101-545	1"	1"
101-546	1 1/4"	1 1/4"
101-547	1 1/2"	1 1/2"
101-548	2"	2"

\* Full port

\*\* UL listed for 400 PSI LP gas service.

### Apollo Bronze LP-Gas Ball Valves

**Features:**

- For LP gas, natural gas, flammable liquids and heated oil
- Adjustable packing gland
- Reinforced TFE seals and seals
- Blow-out-proof stem design
- Large ports to reduce pressure drop
- 600 PSI WOG, 250 PSI LP gas, 150 PSI Saturated Steam



PART NUMBER	SIZE
80-101-01	1/4 FPT
80-102-01	3/8 FPT
80-103-01	1/2 FPT
80-104-01	3/4 FPT
80-105-01	1 FPT
80-106-01	1 1/4 FPT
80-107-01	1 1/2 FPT
80-108-01	2 FPT
80-100-01	3 FPT

### Apollo Carbon Steel Double Union End Ball Valves

Apollo valves feature heavy duty quarter turn lever with steel barrel stock design and reinforced TFE seats and seals for ease of installation and maintenance.

UL listed for LP gas.

600 PSI WOG, 250 PSI LP gas

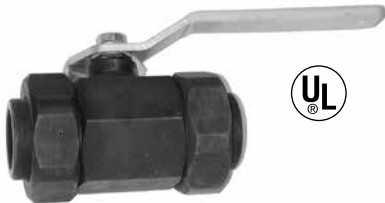

PART NUMBER		SIZE
THREADED ENDS	WELD ENDS	
73-301-01	-	1/4"
73-302-01	-	3/8"
73-303-01	73-403-01	1/2"
73-304-01	73-404-01	3/4"
73-305-01	73-405-01	1"
73-306-01	73-406-01	1 1/4"
73-307-01	73-407-01	1 1/2"
73-308-01	73-408-01	2"

### Jomar Screwed End Ball Valves

The Jomar Valve features a 1/4 turn lever handle operated, CF8M Stainless steel, 3-piece, 4-bolt (swingout pattern), full port, solid ball, and a blow-out proof stem ball valve.

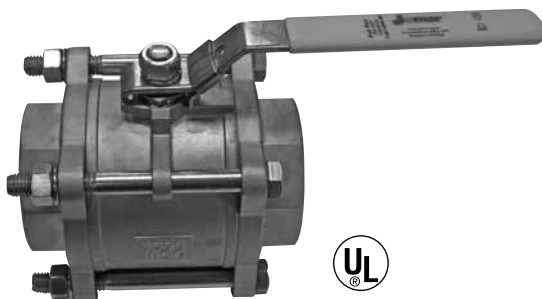

PART NUMBER	SIZE
500-310	3"
500-303	1/2"
500-304	3/4"
500-305	1"
500-306	1/4"
500-307	1 1/2"
500-308	2"

## Ball Valves



The stainless steel ball valves below are rugged and very affordable. Call for pricing!

### RegO Needle Valves

These valves are high quality, "true" throttling valves. Unlike most so-called needle valves, both the body seat and stem are tapered to provide fine, precise control over a wide range of adjustment without stem galling.



PART NUMBER	INLET CONNECTION	OUTLET CONNECTION	HEIGHT	LENGTH
1224WA	1/4" M. NPT	1/4" M. NPT	1 9/16"	1 3/4"
1316WA	9/16"-18 L.H.	1/4" M. NPT	1 9/16"	1 3/4"
1318WA	1/4" M. NPT	9/16"-18 L.H.	1 9/16"	1 3/4"

### Superior Brass Shut-off Valves



V88

PART NUMBER	INLET	OUTLET
V77	9/16"-18LH-M	1/4" MPT
V88	1/4" MPT	9/16 -18LH-M
V332	1/4" FPT	1/4" FPT
V333	1/4" MPT	1/4" MPT
V334	1/4" FPT	1/4" MPT
V335	1/4" MPT	1/4" FPT
V89	1/4" FNPT	9/16"-18LH

### Delta Pacific Flanged Ball Valve

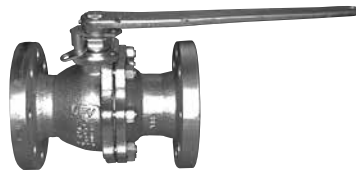

PART NUMBER	SIZE
323F-3	3"
323F-4	4"

### RegO Multipurpose Valve for Liquid Withdrawal of LP-Gas

Designed especially for use as a high capacity liquid withdrawal valve on LP gas. This valve incorporates an integral excess flow valve.

Replacement Handwheel – Part Number: 2507-15C



A8017DP

PART NUMBER	INLET CONNECTION (M. NPT)	OUTLET CONNECTION (F. NPT)	APPROXIMATE EXCESS FLOW LIQUID CLOSING FLOW** (GPM/PROPANE)
A8017DP	1 1/4"	1"	55
A8017DH*	1 1/4"	1"	49
A8017DLP	1 1/4"	3/4"	49

\* Built-in back pressure check valve eliminates need for hydrostatic relief valve in downstream piping segment.

#### Accessories

HYDROSTATIC RELIEF VALVE	VALVE VENT
SS8001J	TSS3169

### RegO Multipurpose Valve for Filling and Vapor Equalizing

This valve has been updated to meet the changes in UL125 for anhydrous ammonia and LP gas. It incorporates a soft seat back check in place of the excess flow valve.

Replacement Handwheel – Part Number: 2507-15C

Replacement Cap and Chain Assembly – Part Number: A8016-93

PART NUMBER	INLET CONNECTION (M. NPT)	FILLING CONNECTION (M. ACME)	FILLING CAPACITY AT 20 PSIG PRESSURE DROP GPM/NH3
A8016DBC	1 1/4"	1 3/4"	95



### RegO Multipurpose Valve for Filling and Liquid Transfer

Designed primarily for use as a combination filler and liquid withdrawal valve on three-opening applicator tanks.

Replacement Handwheel – Part Number: 2507-15C

Replacement Cap and Chain Assembly – Part Number: A8016-93

PART NUMBER	INLET CONNECTION (M. NPT)	OUTLET CONNECTION (F. NPT)	FILLING CONNECTION (M. ACME)	FILLING CAPACITY AT 20 PSIG PRESSURE DROP GPM/NH3	APPROXIMATE EXCESS FLOW LIQUID CLOSING FLOW GPM/NH3
A8018DP	1 1/4"	1"	1 3/4"	74	50

\* Determined at 9 to 12 PSIG differential.

#### Accessories

HYDROSTATIC RELIEF VALVE	VALVE VENT
SS8001J	TSS3169

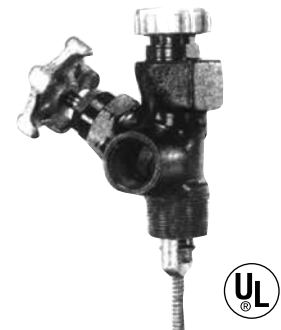



**Before putting your old ASME tanks back in service, update them with the new, safer RegO Chek-Lok valve.**

## RegO Flange Seal Liquid Transfer Angle Valves for Bulk Storage Containers

These valves are designed especially for liquid transfer of LP gas from consumer bulk storage containers when used with a Chek-Lok or equipped with an integral excess flow valve. May also be used for vapor LP gas service.

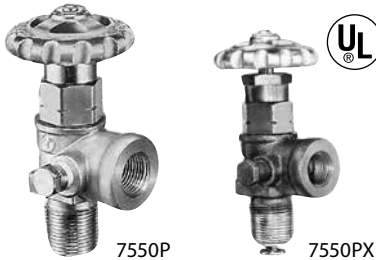

### Accessories

HYDROSTATIC RELIEF VALVE	VALVE VENT
SS8001J	TSS3169
3127U	3165
SS8001U	-

PART NUMBER	INLET CONNECTION (M. NPT)	OUTLET CONNECTION (F. NPT)	INTEGRAL EXCESS FLOW	FLOW AT 1 PSIG (CV) PRESSURE DROP* (GPM/PROPANE)	EXCESS FLOW APPROXIMATE CLOSING FLOW (GPM/PROPANE)**
7550P	3/4"	3/4"	No	13.3	-
A7550P	3/4"	3/4"	No	13.3	-
7550PX	3/4"	3/4"	Yes	-	16.0
A7550PX	3/4"	3/4"	Yes	-	16.0
7551P	3/4"	1/2"	No	8.9	-

\* To obtain approximate flow at other than 1 PSIG pressure drops, multiply flow in table by square root of pressure drop. Example: 7550P @ 9 PSIG = 13.3 x  $\sqrt{9}$  = 39.9 GMP/propane. For NH3 flow, multiply by .90.

## RegO Chek-Lok Valves



7590U with Cap



7590U-10 Union Style Adapter

Designed with unique 1 5/8" UNF threads on both Chek-Lok outlet and adapter inlet. This helps prevent activation of the Chek-Lok without use of the 7590U-10 adapter. Heavy duty construction between body and adapter provides stronger connections.

CHEK-LOK NUMBER	INLET CONNECTION	OUTLET CONNECTION	BODY WRENCH HEX FLATS	APPROXIMATE EFFECTIVE LENGTH	WRENCH HEX FLATS	APPROXIMATE CLOSING FLOW, LIQUID GPM (PROPANE)*
7590U	3/4" M. NPT	1 5/8" UNF	1 5/8"	1 7/16"	1 5/16"	20
7591U	1 1/4" M. NPT	1 5/8" UNF	1 3/4"	1 11/16"	1 5/16"	35

\* Based on horizontal installation of excess flow valve. Flows are slightly more when valves are installed with outlet up, and slightly less when installed with outlet down.

Note: Multiply flow rate by .94 to determine liquid butane flow.

Replacement Nylon Washer 8594-1A

Replacement O-ring for 7590U-10 7590U-6

Replacement Cap and Gasket 7590U-5A

### Union Style Adapters for 7590U and 7591U

The 7590U-10 adapter must be used to connect to the 7590U and 7591U Chek-Lok. This insures a proper connection to open the check mechanism. A built in nylon gasket provides a gas tight seal.



7572C-14A



7572C-15A

ADAPTER NUMBER	INLET CONNECTION	OUTLET CONNECTION	WRENCH HEX FLATS
7590U-10	1 5/8" UNF	3/4" F. NPT	1 3/4"
7572C-14A	3/4" MIP	3/4" FIP	-
7572C-15A	3/4" INM	3/4"	-

## RegO Chek-Lok Liquid Evacuation Adapter for 7590U and 7591U Valves

Designed specifically for use with RegO 7590U and 7591U Chek-Lok Excess Flow Valves. Adapter's operating handle opens and closes equalizing stem in the Chek-Lok valve. Eliminates gas flow through Chek-Lok valve when installing or removing adapter. Use of RegO adapter ensures proper connections and opening of the check mechanism.



ADAPTER NUMBER	INLET CONNECTION	OUTLET CONNECTION	WRENCH HEX FLATS	APPROX. LENGTH
7590U-20	1 5/8" F. UNF	3/4" F. NPT	1 3/4" F. NPT	4 1/8" F. NPT

Replacement Nylon Washer 8594-1A

## RegO Chek-Lok Adapters

These brass adapters must be used to connect to Chek-Lok excess flow valves 7572FC and 7580FC to open the check mechanism properly. A built-in nylon gasket provides a gas-tight seal.

PART NUMBER	INLET CONNECTION	OUTLET CONNECTION
7572C-14A	3/4" M. NPT	3/4" F. NPT
7572C-15A	3/4" M. NPT	3/4" M. NPT

Replacement Nylon Washer 8594-1A



7572C-14A



7572C-15A

## RegO Unloading Adapters for Container Evacuation

Designed to provide an efficient means of evacuating an LP gas container for relocation or repair. They thread directly onto the 1 3/4" ACME male hose connection of RegO Filler Valves used on RegO Double Check Filler Valves and Multivalves.

PART NUMBER	STYLE	FILLER VALVE CONNECTION	HOSE CONNECTION
3119A	In-Line	1 3/4" F. ACME	1 3/4" M. ACME
3120	Angle	1 3/4" F. ACME	3/4" F. NPT
3121	Angle	1 3/4" F. ACME	3/4" F. ACME

Note: 3121 includes Handwheel



3120



3121



3119A

## Hose End Valves



**Don't accept imitations!  
Use the RegO 7901TB on all  
your cylinder filling stations.**

### RegO Quick-acting Valves for Cylinder Filling Hoses

Designed primarily for use on cylinder charging hoses to provide fast, convenient shut-off and fast opening.



PART NUMBER	INLET CONNECTION (F. NPT)	OUTLET CONNECTION (F. NPT)	BODY MATERIAL	FLOW AT 1 PSIG (CV) PRESSURE DROP* (GPM/PROPANE)
7901T	1/4"	1/4"	Brass	1.95
A7553A	1/4"	1/4"	Ductile Iron	1.95
7901TA	3/8"	3/8"	Brass	1.95
7901TB	1/2"	1/4"	Brass	1.95
7901TC	1/2"	1/2"	Brass	1.95
7053T**	1/2"	1/2"	Brass	1.95

\* To obtain approximate flow at other than 1 PSIG pressure drop, multiply flow in table by square root of pressure drop. Example: 7901T @ 9 PSIG =  $1.95 \times \sqrt{9} = 5.85$  GPM/propane. For NH3 flow, multiple propane flow by .90.

\*\* Angle design

### RegO Quick-acting Valves for Crop Driers and Filling Manifold Hoses

7554 Series valves provide instant shut-off and fast opening control on LP gas crop driers. They are also ideal for charging manifold hoses, stationary fuel transfer hoses and other applications requiring quick, positive shut-off. Vent valved installed on downstream side on all valves.



PART NUMBER	INLET & OUTLET CONNECTION (F. NPT)	LOCKING HANDLE	FLOW AT 1 PSIG (CV) PRESSURE DROP* (GPM/PROPANE)
7554SAV	1/2"	No	7.3
7554LAV	1/2"	Yes	7.3
7554SV	3/4"	No	11.5
7554LV	3/4"	Yes	11.5

\* To obtain approximate flow at other than 1 PSIG pressure drop, multiply flow in table by square root of pressure drop. Example: 7554LV @ 9 PSIG =  $11.5 \times \sqrt{9} = 34.5$  GPM/propane.

### RegO Quick-acting Hose End Valves for Bobtail Delivery Trucks and Dispensing Stations

Designed especially for safe operator handling of LP gas in bobtail delivery truck, dispensing systems and anhydrous ammonia nurse tank service. These valves provide instant, full-on flow.

PART NUMBER	INLET & OUTLET BODY DESIGN	CONNECTION (F. NPT)	LOCKING HANDLE	FLOW AT 1 PSIG (CV) PRESSURE DROP* (GPM/PROPANE)
A7707L	Globe	1"	Yes	18.0
A7708L	Angle	1"	Yes	22.0

\* To obtain approximate flow at other than 1 PSIG pressure drop, multiply flow in table by square root of pressure drop. Example: A7708L @ 9 PSIG =  $22.0 \times \sqrt{9} = 66.0$  GPM/propane. For NH3 flow, multiply propane flow by .90.

\*\* See appropriate catalog section for additional information.

\*\*\* Areas under EPA low emission guidelines and bobtails or dispensing stations filling motor fuel are required to use minimum loss valve such as the RegO A7797. See NFPA 58 for additional information.



COMPACT		EXTENDED
BRASS	STEEL	STEEL
3175A	A3175A	A7575L4



### RegO Quick-acting Minimum Loss Hose End Valves for Bobtail Delivery Trucks and Dispensing Stations

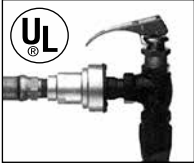

#### Loss at Disconnect is Now Less Than 2CC

Designed to vastly reduce the amount of product vented when disconnecting bobtail delivery trucks, dispensing systems and anhydrous ammonia nurse tanks.

PART NUMBER	INLET CONNECTION (F. NPT)	OUTLET CONNECTION (F. ACME)	LOCKING HANDLE	FLOW AT 1 PSIG (CV) PRESSURE DROP* (GPM/PROPANE)
A7797A	1"	1 3/4"	Yes	16.0

\* To obtain approximate flow at other than 1 PSIG pressure drop, multiply flow in table by square root of pressure drop. Example: A7797 @ 9 PSIG = 16.0  $\sqrt{9}$  = 48.0 GPM/propane. For NH3 flow, multiply propane flow by .90

#### Repair Parts

PART NUMBER	DESCRIPTION
A7797-50	Repair Kit
A7797-75	Bonnet and Stem Assembly
A7797-10M	Nozzle

*Why chance using an unproven design? Use the original A7797.*

#### Hose End Swivels

Allows hose end valve to swivel 360° No lubrication required.



JO-1

PART NUMBER	INLET-OUTLET	DESCRIPTION	MAKE
105-1000	3/4" MNPT	Swivel Connector	Squibb
108	1" MNPT	Swivel Connector	Squibb
JO-1	1" MNPT	Swivel Connector	Full Circle

### RegO Hose End Valve Adapters

These adapters are designed with minimal flow restriction and recommended for use on the outlet of the LP gas delivery truck filler hose. Both incorporate a swivel female ACME connector.

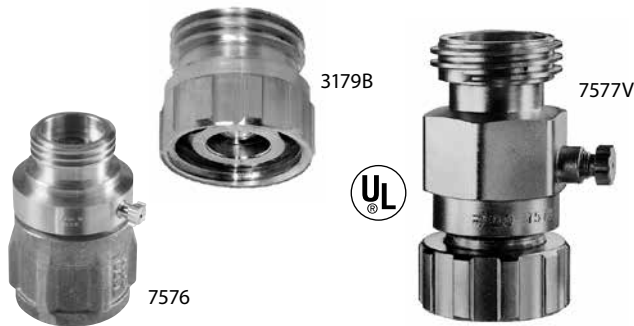

PART NUMBER	BUILT-IN VENT VALVE	FILLER VALVE CONNECTION	HOSE CONNECTION
7577V	Yes	1 3/4" F. ACME	1 3/4" M. ACME
3179B	No	1 3/4" F. ACME	1 3/4" M. ACME
7576	Yes	1 3/4" F. ACME	1 3/4" M. ACME

### Hose Reel

Zero Maintenance Design  
Pre-Tapped for Relief Valve  
Field Repairable  
UL listed



PART NUMBER	SIZE	DESCRIPTION
SMAC-112	1 1/2"	90 degree swivel
SMAC-200	2"	90 degree swivel
SMAC-112ST	1 1/2"	Straight swivel
SMAC-200ST	2"	Straight swivel
SMAC-112-SK	1 1/2"	Repair Kit
SMAC-200RSK	2"	Repair Kit

Other sizes and variations available



ME572

PART NUMBER	DESCRIPTION
ME572EXT	Fill Extensions
ME572EXTHD	Fill Extensions

## RegO Hose End Filler Valve Extension Connectors

Designed especially for liquid filling and vapor equalization of LP gas and anhydrous ammonia.



A7571 Series

PART NUMBER	TYPE OF SERVICE	HOSE CONNECTION (M. NPT)	COUPLING CONNECTION (F. ACME)	APPROX. LENGTH
A7575L2*	Liquid	1/2"	1 3/4"	7"
A7575L3	Liquid	3/4"	1 3/4"	7"
A7575L4	Liquid	1"	1 3/4"	7"
A7575L5**	Liquid	1 1/4"	1 3/4"	7"
A7571LA	Vapor	1/2"	1 3/4"	7"
A7571LB	Vapor	3/4"	1 3/4"	7"

\* Includes 7199-33 adapter, shipped loose.

\*\* Includes A7575L5-1 adapter, shipped loose.

## RegO Hose End Filler Valve Connectors



Style A  
For Liquid Filling



Style B  
For Liquid Filling



Style C\*  
For Vapor Equalizing



Style D\*  
For Vapor Equalizing

PART NUMBER	MATERIAL	STYLE	HOSE CONNECTION (M. NPT)	COUPLING CONNECTION (F. ACME)	TAILPIECE BORE	HOSE END TO NUT	OVERALL LENGTH
3175B	Brass	A	1/2"	1 3/4"	35/64"	2"	2 7/8"
3175	Brass	A	3/4"	1 3/4"	3/4"	2"	2 7/8"
3175A	Brass	A	1"	1 3/4"	3/4"	2"	2 7/8"
3185	Brass	B	1 1/4"	2 1/4"	1 3/16"	2 1/16"	3 1/8"
3195	Brass Nut & Steel Nipple	B	2"	3 1/4"	1 13/16"	2 1/8"	3 5/8"
A3175	Steel	A	3/4"	1 3/4"	3/4"	2"	2 7/8"
A3175A	Steel	A	1"	1 3/4"	3/4"	2"	2 7/8"
A3185	Steel	B	1 1/4"	2 1/4"	1 3/16"	2 1/8"	3 1/8"
A3195	Steel	B	2"	3 1/4"	1 13/16"	2 1/8"	3 5/8"
3171	Brass	C	3/8"	1 1/4"	13/32"	1 3/16"	2 7/16"
3171A	Brass	C	1/2"	1 1/4"	17/32"	1 3/16"	2 7/16"
3181	Brass	C	3/4"	1 3/4"	11/16"	2"	3 1/4"
3181A	Brass	C	1"	1 3/4"	15/16"	1 7/8"	3 1/8"
3191	Brass	D	1 1/4"	2 1/4"	1 3/16"	2 1/8"	3 5/16"

\* Style C and D have nipple (not shown) required to open vapor equalizing check assembly.

**RegO Male ACME X Female NPT Adapters**

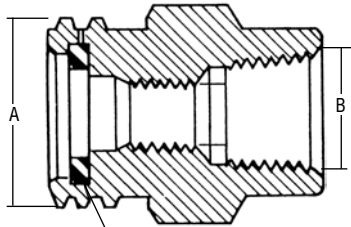

Gasket (Furnished with adapter)  
ACME x Female NPT

PART NUMBER	MATERIAL	A M. ACME	B MNPT	SPARE GASKET PART NUMBER
M498-4/2	Brass	1 1/4"	1/4"	A2797-20R
M498-6/3	Brass	1 1/4"	3/8"	MSW-3
5764A	Brass	1 3/4"	1/4"	A2697-20R
5764B	Brass	1 3/4"	3/8"	A2697-20R
5764C	Brass	1 3/4"	1/2"	A2697-20R
5764D	Brass	1 3/4"	3/4"	A2697-20R
5764E	Brass	1 3/4"	1"	A2697-20R
5766E	Brass	2 1/4"	1"	A3184-8R
5766F	Brass	2 1/4"	1 1/4"	A3184-8R
5768G	Brass	3 1/4"	1 1/2"	A3194-8R
5768H	Brass Brass	3 1/4"	2"	A3194-8R
5768J	Brass	3 1/4"	2 1/2"	A3194-8R
A5764D	Steel	1 3/4"	3/4"	A2697-20R
A5764E	Steel	1 3/4"	1"	A2697-20R
A5768H	Steel	3 1/4"	2"	A3194-8R

**RegO Male ACME X Male NPT Adapters**

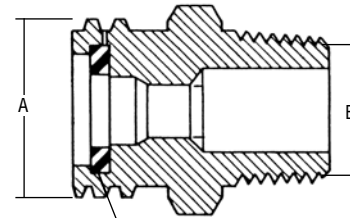

Gasket (Furnished with adapter)  
ACME x Male NPT

PART NUMBER	MATERIAL	A M. ACME	B MNPT	SPARE GASKET PART NUMBER
M498-4/2	Brass	1 1/4"	1/2"	A2797-20R
M498-6/3	-	-	-	-
5763D	Brass	1 1/4"	3/4"	A2797-20R
5765D	Brass	1 3/4"	3/4"	A2697-20R
5765E	Brass	1 3/4"	1"	A2697-20R
5765F	Brass	1 3/4"	1 1/4"	A2697-20R
5767F	Brass	2 1/4"	1 1/4"	A3184-8R
5767G	Brass	2 1/4"	1 1/2"	A3184-8R
5767H	Brass	2 1/4"	2"	A3184-8R
5769H	Brass	3 1/4"	2"	A3194-8R
5769J	Brass	3 1/4"	2 1/2"	A3194-8R
5769K	Brass	3 1/4"	3"	A3194-8R
A5765C	Steel	1 3/4"	1/2"	A2697-20R
A5765D	Steel	1 3/4"	3/4"	A2697-20R
A5765E	Steel	1 3/4"	1"	A2697-20R
A5765F	Steel	1 3/4"	1 1/4"	A2697-20R
A5767F	Steel	2 1/4"	1 1/4"	A3184-8R
A5769H	Steel	3 1/4"	2"	A3194-8R
A5769K	Steel	3 1/4"	3"	A3194-8R

**RegO Male ACME Adapters**

PART NUMBER	MATERIAL	A M. ACME	SPARE GASKET PART NUMBER
5765M	Brass	1 3/4"	A2697-20R
5767M	Brass	2 1/4"	A3184-8R
5769M	Brass	3 1/4"	A3194-8R

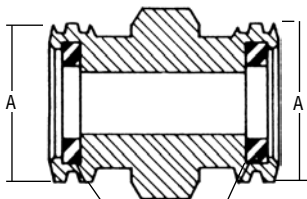

Gasket (Furnished with adapter)  
ACME x ACME

**RegO ACME Adapters**

PART NUMBER	MATERIAL	A M. ACME	B THREAD	SPARE GASKET PART NUMBER
A5764W	Steel	1 3/4"	3/8"*	A2697-20R

\*3/8" -16 UNC Thread.

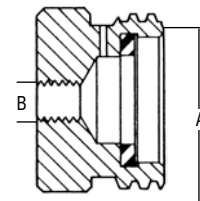

ACME x Miscellaneous  
(Recommended for securing  
hose-end valve when not in use).

## RegO Female ACME Caps



3194-90



MSCP-M3274-9P

PART NUMBER	RING FITS PIPE TO:	CAP WITH CHAIN & RING	MATERIAL	THREAD CONNECTION
		CAP ONLY PART NUMBER		
1708C	3/4"	-	Brass	F.POL (CGA510)
3144-91	3/4"	3144-9P	Cycolac	1 1/4" F. ACME
3174-91	3/4"	MSCP-M3274-9P	Cycolac	1 3/4" F. ACME
3174-93	1 1/4"	MSCP-M3274-9P	Cycolac	1 3/4" F. ACME
3175P	1 1/4"	-	Brass	1 3/4" F. ACME
7141FP	1 1/4"	-	Brass	1 1/4" F. ACME
3184-90	2"	-	Brass	2 1/4" F. ACME
3194-90	2"	-	Brass	3 1/4" F. ACME
A3184-90	2"	-	Steel	2 1/4" F. ACME
A3194-90	3"	-	Steel	3 1/4" F. ACME
ME106-01	3"	ME106	Cycolac	3 1/4" F. ACME
PC555	3/4"	-	Brass	F.CGA555

## ACME Reducing Fittings



TYPE NUMBER		MALE ACME	FEMALE ACME
BRASS	STEEL		
M611	-	1 3/4"	2 1/4"
M612	-	1 3/4"	3 1/4"
5776	A5776	1 3/4"	3 1/4"
5778	-	2 1/2"	3 1/4"

## RegO Plug, Chain and Ring Assembly

Designed as a plug to protect hose end on bulk plants and delivery hose.



PART NUMBER	CHAIN & RING ASSEMBLY	MATERIAL	M. ACME
C5763N	Yes	Nylon	1 1/4"
C5765N	Yes	Nylon	1 3/4"
5765PR	No	Brass	1 3/4"
C5767N	Yes	Nylon	2 1/4"
C5769N	Yes	Nylon	3 1/4"
3705RC	Yes	Brass	M.POL

## QCC Type 1 Caps

Protects threads on OPD valves with QCC Type 1 connection.



PART NUMBER	DESCRIPTION	MATERIAL
907FP	1 5/16" Type 1	Brass
DC-QCC1	1 5/16" Type 1	Plastic
3174-93L	Cap with Lanyard	-
PPC3B	Tear Away Protective Cap	Plastic

Note: DC-QCC1 is a non-threaded dust cover.

**RegO Hose End Connectors for DOT Cylinder Filling**

PART NUMBER	APPLICATION	INLET CONNECTION	OUTLET CONNECTION	MATERIALS
7193D-10	Filling of DOT Cylinder with POL Connections	1/4" M. NPT	M. POL (CGA 510)	Brass and Stainless Steel
7193U-10	Filling of DOT Cylinder with Type 1 Connections	1/4" M. NPT	Type I Connection (1 5/16" F. ACME)	Brass



7193U-10

**POL Adapter**

Adapts POL filler coupling to motor fuel tanks or multivalves. Every fill station and propane powered car should have one.

PART NUMBER	APPLICATION	INLET CONNECTION	OUTLET CONNECTION	MATERIALS
7193T-10	Converts 7193D-10 Adapter from POL to a Type 1 Connection	F. POL CGA 510	Type 1 Connection (1 5/16" F. ACME QCC1)	Brass



7193T-10



PART NUMBER	DESCRIPTION
MSCP-901H	F POL x 1-3/4" ACME adapter

**RegO Hose End Connector for Forklift Cylinder Filling**

PART NUMBER	APPLICATION	INLET CONNECTION	OUTLET CONNECTION	BODY MATERIAL	ACCESSORIES ADAPTER
7193L-10A	Filling of Fork Lift Cylinders*	1/4" M. NPT	1 1/4" F. ACME	Brass	5760A

\* The 7193L-10A is intended to be permanently attached to the filling hose. A 5760A adapter enables the 7193L-10A to be attached to the POL connection on the 7193D-10 at cylinder filling stations to allow for occasional filling of fork lift cylinders.



## Excess Flow Valves



*Did you know RegO has the most complete line of plant equipment? Your salesman will be happy to make a safety inspection of your facility.*

### RegO Excess Flow Valves for Liquid or Vapor Line Service

Designed for top installation, in any position, in liquid or vapor service lines, they are intended for long lines or branch piping where tank mounted excess flow valves cannot suffice.



A1519A6



1519A2



PART NUMBER	BRASS OR STEEL	INLET CONNECTION F. NPT	OUTLET CONNECTION F. NPT	APPROXIMATE CLOSING FLOWS*		
				LIQUID GPM (PROPANE)	VAPOR SCFH (PROPANE)	
					25 PSIG INLET	100 PSIG INLET
1519A2	Brass	1"	1"	25	5,000	8,800
A1519A2	Steel	1"	1"	25	5,000	8,800
1519A3	Brass	1 1/2"	1 1/2"	60	11,500	20,200
1519C2**	Brass	1 1/2"	male 1"	25	5,000	8,800
1519A4	Brass	2"	2"	100	19,000	34,500
A1519A4	Steel	2"	2"	100	19,000	34,500
1519B4	Brass	2"	2"	133	27,700	50,300
A1519B4	Steel	2"	2"	133	27,700	50,300
1519C4	Brass	2"	2"	170	28,590	48,600
A1519A6	Steel	3"	3"	225	45,000	82,000

\* Based on horizontal installation of excess flow.

\*\* Designed for top mounting in storage tank manhole covers for liquid or vapor applications. Inlet has 1" F.NPT optional dip pipe connection to withdraw liquid.

### RegO Excess Flow Valves for Liquid or Vapor

Designed for liquid or vapor use for filling, withdrawal and vapor equalizing in container or line applications.



PART NUMBER	BRASS OR STEEL	INLET CONNECTION M. NPT	OUTLET CONNECTION F. NPT	APPROXIMATE CLOSING FLOWS*		
				LIQUID GPM (PROPANE)	VAPOR SCFH (PROPANE)	
					25 PSIG INLET	100 PSIG INLET
12472	Brass	3/4"	3/4"	4	1,050	1,700
3272E	Brass	3/4"	3/4"	10	2,100	3,700
3272F	Brass	3/4"	3/4"	15	2,800	5,000
3272G	Brass	3/4"	3/4"	20	3,700	6,900
A3272G	Steel	3/4"	3/4"	20	3,700	6,900
3282A	Brass	1 1/4"	1 1/4"	30	5,850	10,000
3282B	Brass	1 1/4"	1 1/4"	40	7,600	13,600
3282C	Brass	1 1/4"	1 1/4"	50	9,000	16,300
A3282C	Steel	1 1/4"	1 1/4"	50	9,000	16,300
7574	Brass	1 1/2"	1 1/2"	90	15,200	28,100
3292A	Brass	2"	2"	75	14,200	24,800
3292B	Brass	2"	2"	100	18,100	32,700
A3292B	Steel	2"	2"	100	18,100	32,700
A3292C	Steel	2"	2"	122	22,100	37,600

\* Based on horizontal installation of excess flow.

### RegO Excess Flow Valves for Container Service

Designed for mounting in threaded full or half couplings in container installations. They may be used for filling, withdrawal or vapor equalizing applications.

PART NUMBER	FOR USE WITH THIS TYPE OF COUPLING	INLET CONNECTION M. NPT	OUTLET CONNECTION NPT	APPROXIMATE CLOSING FLOWS*		
				LIQUID GPM (PROPANE)	VAPOR SCFH (PROPANE)	
					NUMBER	100 PSIG INLET
A8525	Half	1 1/4"	NPT	35	12,540	21,560
A7537L4F	Full	2"	2" Male and 1 1/4" Female	75	13,000	25,600
A7537N4	Half	2"	2" Male and 1 1/4" Female	125	25,000	42,500
A7537N4F	Full	2"	2" Male and 1 1/4" Female	125	25,000	42,500
A7537P4	Half	2"	2" Male and 1 1/4" Female	150	30,500	52,000
A7537P4F	Full	2"	2" Male and 1 1/4" Female	150	30,500	52,000
A7539R6	Half	3"	3" Male and 2" Female	150	32,100	55,500
A7539R6F	Full	3"	3" Male and 2" Female	150	32,100	55,500
A7539T6	Half	3"	3" Male and 2" Female	200	39,400	68,300
A7539V6	Half	3"	3" Male and 2" Female	250	51,100	88,700
A7539V6F	Full	3"	3" Male and 2" Female	250	51,100	88,700



A7539

\* Based on horizontal installation of excess flow valve. Flows are slightly more when valves are installed with outlet up; slightly less when installed with outlet down.

### RegO Excess Flow Valves for Vapor or Liquid

Designed especially for filling, withdrawing or vapor equalizing in half and full coupling installations. Ideal for container service where welded-in dip pipes are not provided. For vapor use, mount in the bottom opening with a threaded dip pipe. For liquid use, mount in the top opening with a threaded dip pipe.

PART NUMBER	INLET CONNECTION M. NPT	OUTLET CONNECTION NPT	APPROXIMATE CLOSING FLOWS*		
			LIQUID GPM (PROPANE)	VAPOR SCFH (PROPANE)	
				25 PSIG INLET	100 PSIG OUTLET
A2137	2"***	2" Male and 1 1/4" Female	50	10,000	17,000
A2137A	2"***	2" Male and 1 1/4" Female	70	14,000	25,000
2139	3"***	3" Male and 2" Female	125	26,500	46,000
2139A	3"***	3" Male and 2" Female	160	32,700	57,200



A2137A

\* Based on horizontal installation of excess flow valve. Flows are slightly more when valves are installed with outlet up; slightly less when installed with outlet down. \*\* 1 1/4" F.NPT dip pipe connection

\*\*\* 2" F.NPT dip pipe connection

### RegO Excess Flow Valve for Pressure Gauges

Designed for container use in pressure gauge installations to minimize excess gas discharge in the event the pressure gauge is sheared.

PART NUMBER	INLET CONNECTION M. NPT	OUTLET CONNECTION F. NPT	WRENCH HEX FLATS	APPROXIMATE CLOSING FLOWS*		
				LIQUID GPM (PROPANE)	VAPOR SCFH (PROPANE)	
					CONNECTION	100 PSIG INLET
2884D	3/4"	F. NPT	1 1/16"	N/A	60	110



\* Based on horizontal installation of excess flow valve. Flows are slightly more when valves are installed with outlet up; slightly less when installed with outlet down.

## RegO Excess Flow Valves for Flange Mounting in Container Service



A3500

Designed for mounting in flanged tank connections with internal threads in the bottom of a container. They may be used in filling, withdrawal or vapor equalizing application. These valves provide high flow capacity with low pressure drop to minimize pump inlet line cavitation.

PART NUMBER	INLET CONNECTION M. NPT	FOR INSTALLATION	APPROXIMATE CLOSING FLOWS*		
			LIQUID GPM (PROPANE)	VAPOR SCFH (PROPANE)	
				25 PSIG INLET	100 PSIG INLET
A3500L4	2"	Slotted Body	75	13,000	22,500
A3500N4	2"	Slotted Body	125	25,000	42,500
A3500P4	2"	Slotted Body	150	30,500	52,000
A3500V6	3"	Slotted Body	250	51,100	88,700

\* Based on horizontal installation of excess flow valve. Flows are slightly more when valves are installed with outlet up; slightly less when installed with outlet down.

## RegO Excess Flow Valves for Liquid or Vapor Withdrawal



A8013D

2723C

These valves are designed for bottom mounting in consumer storage tanks for liquid service. They may also be top mounted for vapor service.

PART NUMBER	INLET CONNECTION M. NPT	OUTLET CONNECTION M. NPT	WRENCH HEX FLATS	APPROXIMATE CLOSING FLOWS*		
				LIQUID GPM (PROPANE)	VAPOR SCFH (PROPANE)	
					25 PSIG INLET	100 PSIG INLET
A8013D	1 1/4"	3/4"	1 7/8"	39	8,700	14,700
A8013DA	1 1/4"	1"	1 7/8"	44	8,700	14,700
A8013DB	1 1/4"	1 1/4"	1 7/8"	55	10,900	19,300
2723C	1 1/4"	3/4"	1 7/8"	20	3,900	6,900

\* 3/4" F.NPT dip pipe connection

\*\* Based on horizontal installation of excess flow valve. Flows are slightly more when valves are installed with outlet up; slightly less when installed with outlet down.

## RegO Excess Flow Valves for DOT Cylinders

Designed for use on portable systems with vapor or liquid.

PART NUMBER	INLET CONNECTION	OUTLET CONNECTION M. NPT	APPROXIMATE CLOSING FLOWS*		
			LIQUID GPM (PROPANE)	VAPOR SCFH (PROPANE)	
				25 PSIG INLET	100 PSIG INLET
3199W	M POL	1/4"	.95	265	500

\* Based on horizontal installation of excess flow.



3199W





## POL Adapters with Excess Flow

Designed for use on LP Gas ASME container manifolds where excess flow protection maybe required for the vapor (POL) vapor outlet connections. POL X 1/2" MPT

PART NUMBER	LIQUID CLOSING FLOW GPM	APPROXIMATE CLOSING FLOWS			
		10 PSIG INLET	25 PSIG INLET	100 PSIG INLET	125 PSIG INLET
3188A	0.95	160	210	350	420
3188B	1.9	310	400	700	840
F202	1.9	-	-	-	-
3188C	2.9	510	660	1180	1430



3188B

## RegO Double Check Filler Valves for ASME Tanks Low Emmissions

Designed to provide fast filling of large motor fuel and ASME domestic tanks the 6579 series incorporates a swing-away lower check which greatly reduces pressure drop across the valve. This lower pressure drop promotes faster filling rates and greater efficiency resulting in more profitable operations.

PART NUMBER		ACME HOSE CONNECTION	TANK CONNECTION M. NPT	WRENCH HEX FLATS	PROPANE LIQUID CAPACITY AT VARIOUS DIFFERENTIAL PRESSURES (GPM)				
CAP ONLY	CAP, CHAIN, AND RING				5 PSIG	10 PSIG	25 PSIG	50 PSIG	75 PSIG
L7579T	L7579C	1 3/4"	1 1/4"	1 7/8"	50	70	111	157	192
L6579*	L6579C*	1 3/4"	1 1/4"	1 7/8"	78	110	174	246	301



L7579T



L6579

\* Swing-away lower back check valve design for higher filing rate.  
NOTE: Multiply flow rate by .94 to determine liquid butane capacity.

Replacement Fill Cap – Part Number: MSCP-M3274-9P

## RegO Double Check Filler Valve for Forklift, Motor Fuel and RV Tanks

Designed to provide fast filling of forklift, motor fuel, and recreational vehicle tanks.

PART NUMBER	STYLE	ACME HOSE CONNECTION	TANK CONNECTION M. NPT	PROPANE LIQUID CAPACITY AT VARIOUS DIFFERENTIAL PRESSURES (GPM)				
				10 PSIG	20 PSIG	30 PSIG	40 PSIG	50 PSIG
7647SCT	w/Lanyard & Cap	1 3/4"	3/4"	14	20	24	27	50
7647DC	w/Lanyard & Cap	1 3/4" & F.POL	3/4"	14	20	24	27	50
7647H	Basic	1/2" FNPT	3/4"	14	20	24	27	50

Replacement Fill Cap – Part Number: MSCP-M3274-9P



7647SCT

## RegO Double Check Filler Valves

Designed to provide fast filling of bobtails, transports and large bulk storage tanks.



7579S

PART NUMBER	ACME HOSE CONNECTION	TANK WRENCH CONNECTION M. NPT	HEX FLATS	PROPANE LIQUID CAPACITY AT VARIOUS DIFFERENTIAL PRESSURES (GPM)				
				5 PSIG	10 PSIG	25 PSIG	50 PSIG	75 PSIG
7579S*	1 3/4"	1 1/2"	2"	44	62	98	139	170
3197C**	3 1/4"	3"	4"	148	210	332	470	575

\* Replacement Fill Valve Cap and Chain Part Number 3174-90; Cap Only MSCP-3274-9P

\*\* Replacement Brass Cap and Chain 3174-90; Plastic Cap and Chain ME106-01; Plastic Cap Only ME106

## RegO Single Check Filler Valves for Storage Tanks with Supplementary Back Check Valves

Designed to provide fast filling of bobtails, transports and large bulk storage tanks when used with RegO back check valves.



3174C



3194C/6584C

PART NUMBER	ACME HOSE CONNECTION	OUTLET CONNECTION M. NPT	PROPANE LIQUID CAPACITY AT VARIOUS DIFFERENTIAL PRESSURES (GPM)				FOR USE WITH BLACK CHECK VALVE
			5 PSIG	10 PSIG	25 PSIG	50 PSIG	
3174C	1 3/4"	1 1/4"	23	33	52	74	3176
6584C	2 1/4"	2"	156	220	348	492	A3186
3194C	3 1/4"	3"	147	208	329	465	A3196

### RegO Back Pressure Check Valves

Designed to provide protection of a container opening when desired flow is always into the vessel and may be used in line applications where flow must be limited to one direction.

PART NUMBER	BODY	INLET CONNECTION F. NPT	OUTLET CONNECTION M. NPT	PROPANE LIQUID CAPACITY AT VARIOUS DIFFERENTIAL PRESSURE (GPM)			
				5 PSIG	10 PSIG	25 PSIG	50 PSIG
3146	Brass	3/4"	3/4"	11	16	25	36
3176	Brass	1 1/4"	1 1/4"	28	40	63	89
A3146	Steel	3/4"	3/4"	11	16	25	36
A3176	Steel	1 1/4"	1 1/4"	28	40	63	89
A3276BC*	Steel	1 1/4"	1 1/4"	32	45	73	103
A3186	Steel	2"	2"	124	175	276	391
A3187S*	Steel	2" M.NPT & 1 1/4" F.NPT	2" M.NPT & 1 1/4" F.NPT	60	110	225	350
A3196	Steel	3"	3"	297	420	664	939

\*Soft seat



3146



A3276BC



A3187S

### RegO Swing-away Back Pressure Check Valves

Designed to provide protection of a container opening when desired flow is always into the vessel. May be used in line applications where flow must be limited to one direction.

PART NUMBER	BODY	INLET CONNECTION F. NPT	OUTLET CONNECTION M. NPT	PROPANE LIQUID CAPACITY AT VARIOUS DIFFERENTIAL PRESSURES (GPM)			
				5 PSIG	10 PSIG	25 PSIG	50 PSIG
6586D	Brass	2"	2"	190	270	420	600
A6586D	Steel	2"	2"	190	270	420	600



6586D

### RegO Back Pressure Check Valves for Flanged Installation

Designed to provide high flow capacity and allow more efficient tank filling than conventional designs. All steel and stainless steel construction allows use in LP or NH3 service.

PART NUMBER	FLANGE CONNECTION M. NPT	WRENCH HEX FLATS	OVERALL LENGTH	PROPANE LIQUID CAPACITY AT VARIOUS DIFFERENTIAL PRESSURES (GPM)			
				5 PSIG	10 PSIG	25 PSIG	50 PSIG
A3400L4	2"	Slotted	5 1/4"	223	316	500	707
A3400L6	3"	Slotted	5 9/32"	424	600	949	1342

NOTE: For installation in flange tank connections with internal threads. Multiply flow rate by .94 to determine liquid butane capacity and by .90 for liquid anhydrous ammonia capacity.



A3400L6

## Back Check Flow Indicators

The valves on this page with the exception of the Taylor, function as a back check as well as a flow indicator. Only RegO lets you actually see the product flowing to provide maximum pump efficiency.

### Back Check with Sight Flow Indicator

#### RegO Sight Flow Indicator with Back Check

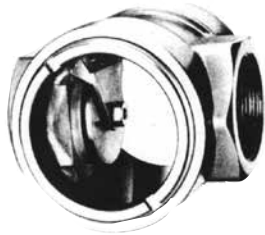

PART NUMBER	INLET / OUTLET
A7794	2" FNPT
A7796	3" FNPT

#### Replacement Parts

PART NUMBER	INLET/OUTLET
A7794-10	2" O-Ring
A7794-11	2" Replacement Glass
A7794-12K	2" Gasket
A7794-13	2" Retainer Ring
A7795-14	Screw Set
A7795-8	3" Indicator Assembly
A7795-10	3" O-Ring
A7795-11	3" Replacement Glass
A7795-12K	3" Gasket

#### Fisher Back Check with Flow Indicator



PART NUMBER	BODY SIZE
G201-10	1 1/4" FNPT
G201-16	2" FNPT
G201-24	3" FNPT

#### Corken Flo-Chek with Indicator



PART NUMBER	FNPT
FC125	1 1/4"
FC200	2"
FC300	3"

### Flow Indicator

Indicates direction of flow only. Does not function as a back check.

PART NUMBER	PIPE SIZE	INCLUDES
5520-2	2"	5305 Adapter (2" MNPT)
5520-3	3"	5305 Adapter (2" MNPT)*

\*Also requires 3" x 2" hex bushing, not included.

#### Taylor-Flo Indicator



### Rego Threaded Internal Valves



A3209D050



A3209D

Designed primarily for use with LP gas and anhydrous ammonia as a main valve on small capacity pumping systems, NH<sub>3</sub> nurse tanks and in-line installations. It may also be installed in the vapor equalizing opening on bobtail delivery trucks.



A3213DT



A3212D250

Designed primarily for use with LP gas and anhydrous ammonia for liquid withdrawal; vapor transfer or vapor equalization of bobtail delivery trucks, transports, stationary storage tanks, and in-line installations. The valve may be operated manually by cable or pneumatically.

PART NUMBER	INLET CONNECTION M. NPT	OUTLET CONNECTION F. NPT	CLOSING FLOW (GPM) HALF COUPLING		CLOSING FLOW (GPM) FULL COUPLING	
			LP GAS	NH <sub>3</sub>	LP GAS	NH <sub>3</sub>
			A3209D050	1 1/4"	1 1/4"	50
A3209D050	1 1/4"	1 1/4"	50	45	-	-
A3209D080	1 1/4"	1 1/4"	80	72	-	-
A3212R105	2"	2"	105	95	65	59
A3212R175	2"	2"	175	158	100	90
A3212R250	2"	2"	250	225	130	117
A3213D150	3"	3"	150	135	125	113
A3213D200	3"	3"	200	180	160	144
A3213D300	3"	3"	300	270	250	225
A3213D400	3"	3"	400	360	325	293
A3213RT150*	3"	3"	150	135	125	113
A3213DT200*	3"	3"	200	180	160	144
A3213DT300*	3"	3"	300	270	250	225
A3213DT400*	3"	3"	400	360	325	293

\* Has two 3" outlets in T configuration.

### Accessories

SERIES NUMBER	PNEUMATIC ACTUATOR	THERMAL LATCH
A3209	A3209PA	A3209TL
A3210	A3210PA-R1	Included
A3213	A3213PA*	A3213TL
A3212	A3212PA	A3212TL

\* Thermal fuse installed complies with DOT thermal protection requirements.

See page 62 for Repair Kit

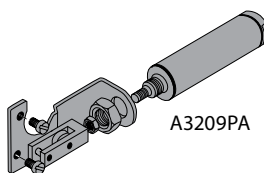

A3209PA

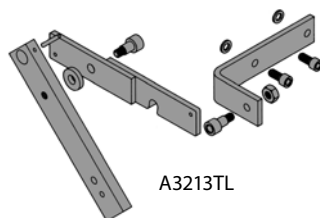

A3213TL

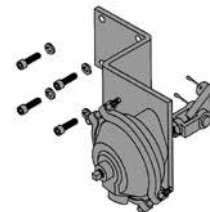

A3213PA

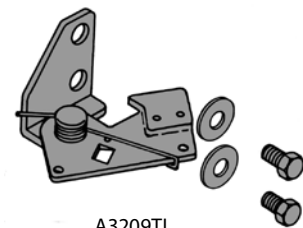

A3209TL



**Make sure you specify a RegO internal valve or Flomatic on your next bobtail.**

## Rego 3" Flanged Internal Valves

Designed primarily for LP gas and anhydrous ammonia filling and/or withdrawal on MC331 bobtail delivery trucks, transports and stationary storage tanks with flanged pumps or piping. Installation is quick and easy, and the valve may be operated manually by cable or pneumatically. Lever available on right or left side to allow for installation without the use of extra pulley.



PART NUMBER		OPERATING LEVER POSITION	INLET CONNECTION	OUTLET CONNECTION	CLOSING FLOW GPM	
SINGLE FLANGE BODY*	DOUBLE FLANGE BODY***				LP-GAS	NH3
A3217FR160	A3217DFR160	Right Side	3" 300# ANSI RF Modified Flange**	3" 300# ANSI RF Flange	160	145
A3217FL160	A3217DFL160	Left Side	3" 300# ANSI RF Modified Flange**	3" 300# ANSI RF Flange	160	145
A3217FR210	A3217DFR210	Right Side	3" 300# ANSI RF Modified Flange**	3" 300# ANSI RF Flange	210	190
A3217FL210	A3217DFL210	Left Side	3" 300# ANSI RF Modified Flange**	3" 300# ANSI RF Flange	210	190
A3217FR260	A3217DFR260	Right Side	3" 300# ANSI RF Modified Flange**	3" 300# ANSI RF Flange	260	236
A3217FL260	A3217DFL260	Left Side	3" 300# ANSI RF Modified Flange**	3" 300# ANSI RF Flange	260	236
A3217FR410	A3217DFR410	Right Side	3" 300# ANSI RF Modified Flange**	3" 300# ANSI RF Flange	410	372
A3217FL410	A3217DFL410	Left Side	3" 300# ANSI RF Modified Flange**	3" 300# ANSI RF Flange	410	372

\* Valve supplied with 16 nuts and 8 studs for mounting.

\*\* Modified bore = 4 5/8" diameter with 5 3/4" diameter raised face.

\*\*\* Valve supplied with 16 studs and 24 nuts.

These pneumatic actuators are designed specifically for use with the A3217 Series 3" internal valves. The diaphragm design provides a convenient means of opening and closing the valve from a remote location, using either air or nitrogen.

### Features:

- Diaphragm type – no seals to leak
- Easily installed on internal valve "in-line"
- Utilizes standard air break chamber with proven performance in heavy truck applications
- Compatible with existing air interlock systems
- Operates with pressures of 50-150 PSIG
- Thermal fuse installed complies with DOT thermal protection requirements



A3217FPA

### Accessories

PART NUMBER	PNEUMATIC ACTUATOR
A3217FR	13217FPA
A3217FL	A3217FLPA

**RegO Flomatic Internal Valves for Bobtail Delivery Trucks, Transports and Large Stationary Tanks**

Designed primarily for LP gas and anhydrous ammonia liquid withdrawal on MC331 bobtail delivery trucks, transports and large stationary storage tanks with flanged connections. The valve is fully automatic, opening and closing as the pump is turned on or off. Unloading is quicker and turnaround faster to provide more profitable operation. The fully internal design reduces possibility of spillage that may result from a collision.



Supplied with A7853A 3-way valve, A7884-201 filter, studs, nuts and gaskets.

PART NUMBER	INLET CONNECTION ANSI FLANGE	OUTLET CONNECTION ANSI FLANGE
A7883FK	3" - 300#*	3" - 300#
A7884FK	4" - 300#**	4" - 300#

\* With 4 13/16" diameter bore  
\*\* With 5 13/16" diameter bore

PART NUMBER		FLOMATIC REPLACEMENT PARTS
		DESCRIPTION
A7883F	A7884F	
A7884-201	A7884-201	Filter
A7883-30	7565-48	Gasket (Bottom Flange)
A7884F-43	A7884F-43	Bolts with Nuts
A7883-29	7884-29	Gasket (Upper)
A7883F-37SS	A7883F-37SS	Guide-Pump Prime Valve
A7884-60	A7884-60	Pump Prime Valve Assembly
7884-33	7884-33	Gasket (Pump Prime Valve)
A7883F-33	A7883F-33	Stem Assembly
A7883-5	7884-5	Seat Disc
A7883-7T	7884-7T	X-Seal (Upper)
7884-6T	7884-6T	X-Seal (Lower)
A7883F-50	A7883F-50	Complete Rebuild Kit
A7883F-150	A7884F-150	Repair Kit
A7883F-80	A7884F-80	Lower Piston Rebuild Kit
A7853A-74	A7853A-74	Control Valve

**Accessories**

FILTER	3-WAY VALVE
A7884-201	A7853A



A7853A

This valve controls the sensing line to the Flomatic. Valve is held open by a cable with a fusible link and return spring. If fusible link melts, valve closes and causes Flomatic to lose its prime and valve closes.



A7884-201

Disposable filter removes contaminants as small as 20 microns from liquid in the sensing line preventing valve malfunction. Filter should be replaced at least once a year and every immediately after every tank hydrostat.

## Rego 4" Flanged Internal Valve for Transports and Large Stationary Storage Tanks

Designed primarily for LP-gas and anhydrous ammonia service on MC331 transport pressure vessels and large stationary storage tanks.



A3219F6002

PART NUMBER*	INLET CONNECTION	OUTLET CONNECTION	CLOSING FLOW GPM	
			LP-GAS	NH3
A3219F600L	4" 300# ANSI RF Modified Flange**	4" 300# ANSI RF Flange	600	544

\* Valve supplied with 16 nuts and 8 studs for mounting.

\*\* Modified bore = 5 7/8" diameter with 7" diameter raised face.

\*\*\* A3219FPA Thermal fuse installed on actuator complies with DOT thermal protection requirements.

### Accessories

PNEUMATIC ACTUATOR	REMOTE THERMAL RELEASE
A3219FPA***	A3219RT (2)



A3219FPA\*\*\*

## Rego Remote Thermal Release for DOT MC331 Pressure Vessel



A3219RT

Designed especially for use with internal valves installed in DOT MC331 pressure vessels. The A3219RT provides a remote means of mechanical closure along with thermal protection, as required by DOT MC331.

PART NUMBER	FOR USE WITH	RELEASE TEMPERATURE	SPRING LOAD FULLY EXTENDED	AFTER 4" TRAVEL	MINIMUM NUMBER /REQUIRED BY MC331
A3219RT	Internal Valves	212° F.	≈100 lbs.	≈50 lbs.	2

## Rego Remote Cable Controls for Internal Valves

The 3200C Remote Cable Kit is designed especially for use with the 3200L Remote Operating Lever to operate internal valves from a remote location.

PART NUMBER	DESCRIPTION	CONTENTS
3200C	Remote Cable Kit	100 Foot Cable, 6 Cable Clamps, Quick Link, Sign, Fuse Link, Steel Nut and Bolt
3200L	Operating Lever	Lever Assembly
7606RM	Cable Release	Cable Release



7606RM



**RegO Emergency Shutoff Valves for Bulk Plants**

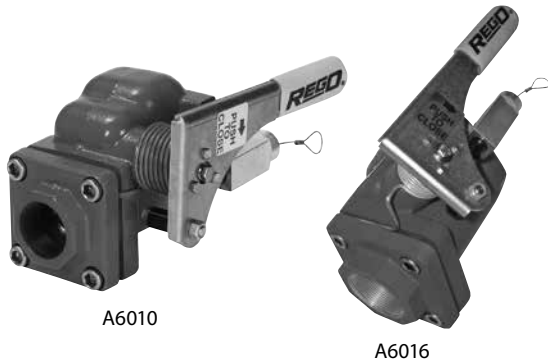

Especially designed for installation in liquid or vapor transfer lines at LP-gas bulk plants to provide for quick shut off of liquid or vapor flow in the event of an accidental pull-away or hose rupture.

PART NUMBER	FOR USE ONLY WITH	INLET & OUTLET CONNECTIONS	LIQUID FLOW @ 10 PSIG PRESSURE DROP (GPM)	
			LPG	NH3
A6010	LPG/NH3	1 1/4" F.NPT	259	233
A6016	LPG/NH3	2" F. NPT	711	640
A6024	LPG/NH3	3" F.NPT	1325	1173

**ESV Pneumatic Controls**



**Fisher ESVs for Railroad Cars**

Series N562 Snappy Joe ESVs are designed expressly for attachment to the shutoff valves on railroad tank cars. Usually three N562s will be used, two on the liquid lines and one on the vapor line. NFPA 58 regulations call for ESV protection on both sides of the transfer hose or piping. Hardened stainless steel F.NPT threads. Uses customer supplied Sch 80 nipple.

PART NUMBER	DESCRIPTION
7781AFPN-1	Cylinder assembly kit to convert 7781AF ESVs to pneumatic shutdown.
6016-60D	Cylinder assembly kit to convert 6016 ESVs to pneumatic shutdown.
6016-60C	Pneumatic remote for 6016. Open/close actuator.
7605PN-50	Pneumatic remote shutdown system kit, complete with 100' of tubing, fittings, 1 charging valve assembly and 1 remote shutdown valve assembly.
7605APN-8A	Extra shutdown valve assembly.
7605AP-16	1/4" tubing tee, w/nuts.
7605AP-15	1/8" NPT x 1/4" tubing, straight connector.



TYPE NUMBER	SHUTOFF NIPPLE LENGTH	VALVE CONNECTION	HOSE CONNECTION
N560-26	5.15"	2" FNPT	3 1/4" M. ACME

**ESV Remote Cable Controls**

PART NUMBER	DESCRIPTION
7609-50	Transfer hose cable release kit. Attaches to ESV and hose for automatic closing as hose stretches.

## Pneumatic Tubing and Fittings

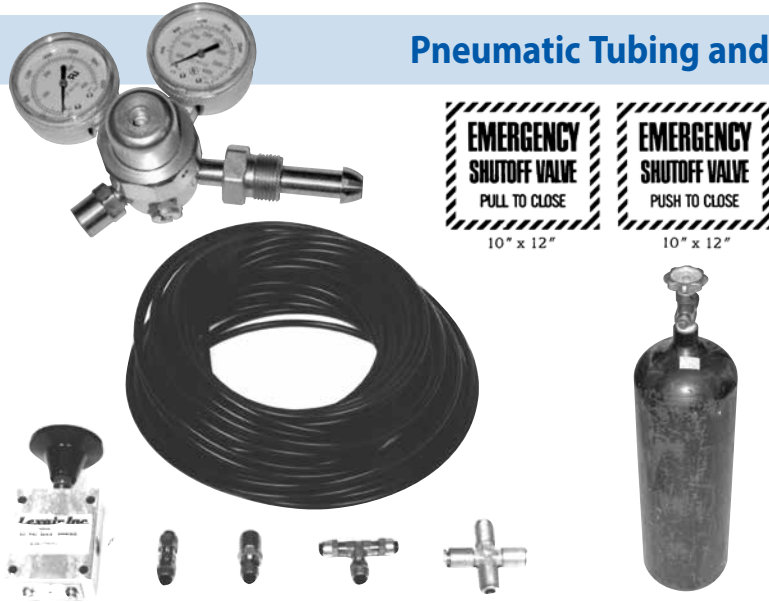

PART NUMBER	DESCRIPTION
3331	3-Way Control Valve 1/4 FPT
44P	Poly Tubing 1/4" X 100 FT
44P-5C	Poly Tubing 1/4" X 500 FT
AP62P4	Union 1/4" Tube X 1/4" Tube
AP61P4	Nut & Ferrule X 1/4" Tube
AP64P4	Tee 1/4" Tube
AP68P4x4	Adapter 1/4" Tube X 1/4" MPT
AP68P4x2	Adapter 1/4" Tube X 1/8" MPT
AQ52P4	Cross 1/v4" Tube
AQ65P4	90° Elbow 1/4" Tube X 1/4" Tube
P-81	Sign, Pull to Close
P-82	Sign, Push to Close
W-423	Nitrogen Regulator
Nitro Tank	Nitrogen Tank

## RegO Pneumatic Remote Control Kit

Control kit with components for connecting and charging the pneumatic controls from a source of compressed gas (air or nitrogen) to a RegO liquid or vapor ESV. Includes charging valves with low pressure indicator, operating valves, 100 feet of 1/4" plastic tubing and tube fittings.

PART NUMBER	DESCRIPTION	PART NUMBER	DESCRIPTION
7781AFPN-1	Cylinder assembly kit to cover 7781AF ESVs to pneumatic shutdown	7605AP-19	Bushing 1/8" x 1/4"
7605APN-1	Cylinder assembly kit to cover 7605B ESVs to pneumatic shutdown	7605AP-81	Bracket and Label
7605AP-10	Emergency Valve	7605AP-82	Bracket and Charging Valve
7605aAP-12	Charging Valve	2303-3	Screw
7605AP-13	Tee	7605A-BT	Black tubing 1/4" x 100'
7605AP-14	Hex Nipple	7605PN-30	Instruction Sheet
7605AP-15	Tubing Connector	7605APN-8A	Extra shutdown valve assembly
7605AP-16	Tubing Tee	7605AP-16	1/4" tubing tee, with nuts
7605A-17	Union (Plastic Tube)	7605AP-15	1/8" NPT X 1/4" tubing, straight connector
7519-64	Indicator		



## RegO Pull-away Valves for Transfer Operations

Designed especially to provide pull-way protection for LP-gas and anhydrous ammonia transfer operations including transport and delivery truck loading and unloading, engine fuel container filling and miscellaneous cylinder filling operations.

Brackets

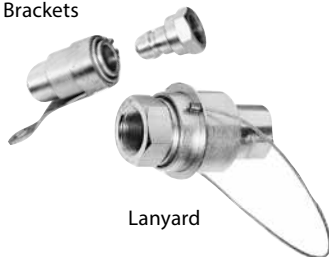

Lanyard

PART NUMBER	INLET/OUTLET CONNECTIONS (F. NPT)	DISCONNECT FORCE (APROX-LBS)	RECONNECT FORCE (APPROX-LBS)	MOUNTING CONNECTION
A2141A6	3/4"	130	80	Bracket
A2141A6L	3/4"	130	80	Lanyard
A2141A8	1"	75	50	Bracket
A2141A8L	1"	75	50	Lanyard
A2141A10	1 1/4"	160	25	Lanyard
A2141A16	2"	300	50	Lanyard

**RegO Bleeder Valves**

Especially designed to bleed off liquid or vapor pressures trapped in transfer lines. When installed in the downstream boss of RegO globe and angle valves used at the end of a liquid transfer hose, the bleeder valve allows for the controlled venting of the product and indicates to the operator that the valves are closed and he can disconnect the coupling. They may also be used as a fixed liquid level gauge where the dip tube is part of the container.

PART NUMBER	SERVICE	CONNECTION	ACTUATION	ACCESSORIES WARNING PLATE KIT
3165C	LP Gas Only	1/4" M.NPT	Knurled	2550-40P
TSS3169	LP Gas & NH <sub>3</sub>	1/4" M.NPT	Tee Handle	2550-40P
1931-24A	Thumbscrew Only	-	-	-

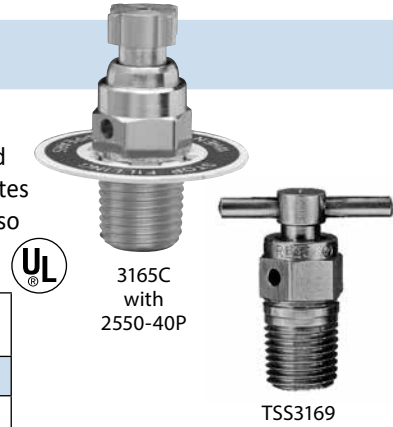

**RegO Fixed Liquid Level Gauges**

Especially designed to provide a visible warning when containers are filled to the maximum permitted filling level. At the start of the filling operation, with the vent stem opened, the valve discharges vapor. When the maximum permitted filling level is reached, the valve discharges liquid. These valves are normally furnished with a 12", 3/16" O.D. dip tube and incorporate a No. 54 drill size orifice. An optional instruction plate with "Stop Filling When Liquid Appears" may be ordered for use with these valves.

PART NUMBER	SERVICE	CONNECTION	ACTUATION	DIP TUBE LENGTH	ACCESSORIES WARNING PLATE KIT
3165CF05.6	LP Gas Only	1/4" M.NPT	Knurled	5.6"	2550-40P
3165CF12.0	LP Gas Only	1/4" M.NPT	Knurled	12"	2550-40P

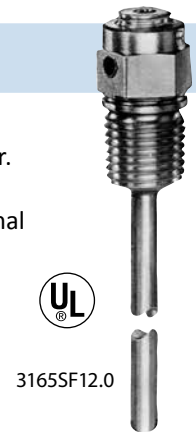

**RegO Hydraulic Automatic Cylinder Filling System**

Designed to provide accurate, economical filling of LP-Gas DOT and fork lift cylinders by weight. Filling stops automatically as the total weight of the cylinders reaches the amount pre-set on the scale. One individual can efficiently handle up to four cylinder filling operations simultaneously, to maximize profits, increase efficiency and allow servicing of more customers.

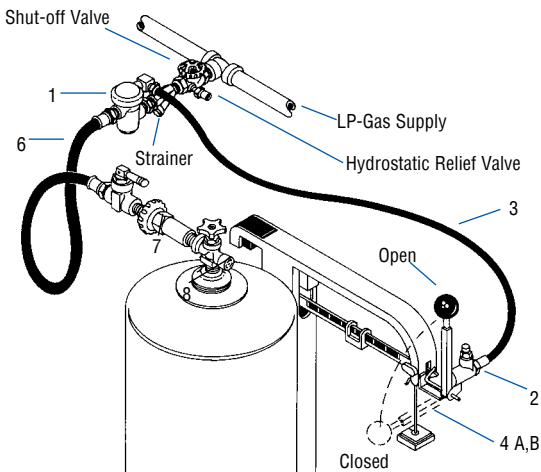

KEY NUMBER	DESCRIPTION	SIZE	PART NUMBER
Assembly for Fairbanks Morse. Includes items 1 through 8 below.			7194MD
1	Propane Control Valve	1/2" NPT female with 1/8" NPT female hydraulic connection	7177
2	Master Cylinder, with Actuator lever	1/8" NPT hydraulic connection	7188
3	Hydraulic hose assembly	3/16" I.D. with 1/8" NPT male ends, 43 1/2" overall length	7194-1
4A	Bracket kit for Fairbanks Morse scales, complete with screws, washers, nuts, and instructions	----	7194M-3K
5	Can of hydraulic fluid, complete with filling spout	1 1/2 Ounce	7188-21
6	Propane filling hose assembly	1/2" I.D., with 1/2" NPT male ends. 50 1/2" overall length	7193-4
7	Quick-acting shut-off valve	1/2" NPT inlet X 1/4" NPT outlet	7901TB
8*	Soft nose cylinder connector	1/4" NPT male X POL male	7193D-10

\*Any of the RegO hose end adapters for cylinder filling may be used with these systems.

## RegO Repair Kits for Cylinder and Service Valves

### LP-Gas Cylinder and Service Valves

PART NUMBER	KIT NUMBER	KIT CONTENTS
901 Ser., 903 Series	903-50, 903-51	Bonnet assembly, handwheel, self tapping screw
9100 Series	19100-50B	Bonnet assembly, handwheel, screw, washer
9100 Series	19104-50	MultiBonnet, handwheel, screw, ID Plate
3100 Ser., 7100 Ser.	3100-81K Conversion Kit	Bonnet and stem assembly, gasket (Conversion Assembly)
3100 Ser., 7100 Ser.	3100-80A	Diaphragm, bonnet, stem assembly
3100 Ser., 7100 Ser.	3100-80B	Diaphragm assembly, back seat, washer
8100 Series	8100-50	Bonnet, valve stem O-ring assembly
19104-50	19104-80	MultiBonnet replacement packing
9101P	19101-50	Bonnet and small handrail



903-50



903-51



9107-31

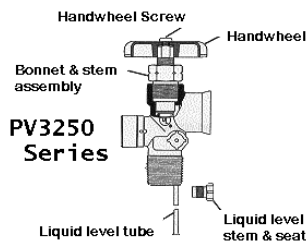

### Sherwood Cylinder, Multi and Plumbers Pot Valves

VALVE NUMBER	3329, 2030C, CP, 2033, 1445C	2035A, 2035AP, 3250A, ALM	1427B, 1425B, 1426B, 1445B, 1446B	3359AS, 3359ASW
DESCRIPTION	PART NUMBERS			
Handwheel Screw	3740-13	3740-13	3740-13	3740-13
Handwheel	3329-7	1901	1901S	1901S
LH Bonnet, Stem, O-Ring, Seat Assy	-	-	-	3250-8ALH
Vent Plug	1931-24A	1931-24A	-	-
Dual Bonnet	6775-60	-	-	-

PART NUMBER	DESCRIPTION
3429-100	Bonnet replacement assembly for existing Sherwood valves Pv2033CLDB series and PV2033CL series
6775-60	Replacement kit contains handwheel, bonnet, and stem to repair 3429-100

### RegO Repair Kits for Multivalves

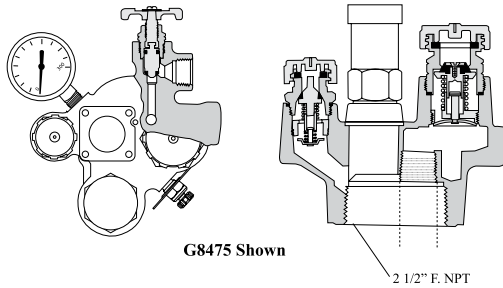

G8475 Shown

2 1/2" F. NPT

#### Multivalves - Service Valve

PART NUMBER	KIT NUMBER	KIT CONTENTS
6532A Ser.	-	Self Tapping screw, bonnet, stem O-ring assembly, hand-wheel
6533A Ser.	-	
6543A Ser.	19100-50B	
7556V Ser.	-	
G8475 Ser.	-	MultiBonnet, handwheel, screw, ID Plate
8555D Ser.	-	
8555DL Ser.	19104-50	
8593A Ser.	-	

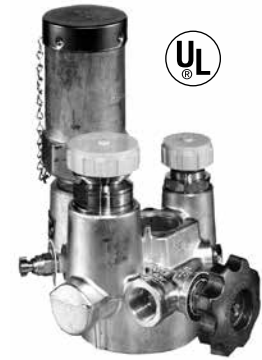

G8475 Series

#### Multivalves - Filler Valve

PART NUMBER	KIT NUMBER	KIT CONTENTS
6533 Ser.	-	-
6542 Ser.		
6543 Ser.	6542B-80 with out filler body	Stem and seat disc assembly, spring, gaskets
8555 Ser.		
8555DL Ser.		
G8475 Ser.	8475-50 with upper body	Upper body, seat disc and retainer assembly, spring, gaskets
8593S Ser.		
G8475 Ser.	8475-80 without upper body	Seat disc and retainer assembly, spring, gaskets
8593A Ser.		
1475	1475-80	Back pressure check stem assembly, spring cap



8593 Series

#### Multivalves - Vapor Equalizing

PART NUMBER	KIT NUMBER	KIT CONTENTS
7556V Ser.	8475-51A with vapor body	Vapor body, stem and seat disc retainer assembly, spring, gaskets
G8475 Ser.		
8475 Ser.		
8477 Ser.	8475-81A without vapor body	Stem and seat disc assembly, spring, gaskets
8593 Ser.		



8555DL Series

#### Multivalves & Service Valves with MultiBonnet

PART NUMBER	KIT NUMBER	KIT CONTENTS
6532 R Ser.	19104-80	Upper packing nut for MultiBonnet
6533 R Ser.	19104-80	Upper packing nut for MultiBonnet
6542 R Ser.	19104-80	Upper packing nut for MultiBonnet
6543 R Ser.	19104-80	Upper packing nut for MultiBonnet
7556R Ser.	19104-80	Upper packing nut for MultiBonnet
G8475R Ser.	19104-80	Upper packing nut for MultiBonnet
8555R Ser.	19104-80	Upper packing nut for MultiBonnet
8593R Ser.	19104-80	Upper packing nut for MultiBonnet
9101R Ser.	19104-80	Upper packing nut for MultiBonnet



6533 Series



7556 Series



**Need a ball valve?  
We carry ball valves from  
6 different manufacturers.  
Call Team Tarantin!**

## RegO Repair Kits for Quick-Acting Hose End Valves

### Quick Acting Hose End Valves

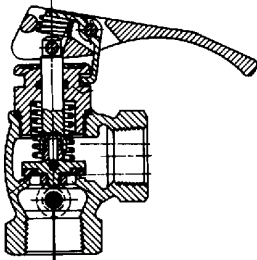

A7708

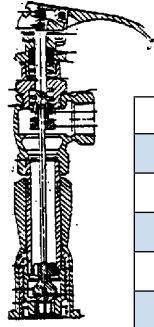

A7797



7901TA

KIT NUMBER	VALVE NUMBER	KIT CONTENTS
7553T-50	7553S, T	Handle Stem Bonnet Seal ASsy
7553T-80	7553T	Seal Disc, Seal Packing
7901T-50	7901T	Handle Stem Bonnet Seal ASsy
7901T-80	7901T	Seal Disc, Seal Packing
A7797-75	A7797	Stem, Bonnet and Level Assembly Washer, O-Ring Pressure
A7797-50	A7797	Seal Ring, Groove Pin Seat Disc, Jam Rig Washer, O-Ring Pressure
A7707-50	A7707/08 Series	Seal Ring, Seat Disc, Gaskets, Groove Pin
A7707-75	A7507/08 LHB, LHD, LHDM, A7707/08 Series	Stem, Bonney and Seal Housing, Assembly
A7797-10M	A7797	ACME Coupler
A7507LH-8	A7797	Lever Arm
A7507LH-13	A7797	Groove Pin
A7507LH-11D	A7797	Bonnet Wear Washer

## RegO Repair Kits for Double Check Filler Valves

### Filler Valves



7579S



7647SCT

PART NUMBER	KIT NUMBER	KIT CONTENTS
7647SCT	7647B-80 w/o filler body	Seat disc and retainer assembly, spring, gaskets, loctite cement
L6579	7579-50	Filler body, seat disc and retainer assembly, spring, gaskets
L7579T	7579-80 w/o filler body	Seat disc and retainer assembly, spring, gaskets

**RegO Repair Kits for Globe and Angle Valves**

**Repair Kits**

PART NUMBER	KIT NUMBER	KIT CONTENTS
7505AP	A7505-50	
A7506AP	A7505-50	
A8016A	A7505-50	
A7016A	A7505-50	
A7507AP	A7507-50	
A7508AP	A7507-50	
A7509A0	A759A-50 (No O-rings)	
A7510AP	A759A-50 (No O-rings)	
A7509BP	A7509-50	
A7510BP	A7509-50	
A7511AP	A7511-50	
A7511FP	A7511-50	
A7512AP	A7511-50	
A7512FP	A7511-50	
A7513AP	A7513-50	
A7513FP	A7513-50	
A7514AP	A7513-50	
A7514FP	A7513-50	
A7515AP	A7515-50	
A7516AP	A7515-50	
A7517AP	A7515-50	
A7517FP	A7515-50	
A7518AP	A7515-50	
A7518FP	A7515-50	
A7704	A7705-50	
A7705	A7705-50	
A7706	A7705-50	
TA7509BP	TA7509B-50	
TA7510BP	TA7509B-50	
TA7511AP	TA7511A-50	
TA7511FP	TA7511A-50	
TA7512AP	TA7511A-50	
TA7512FP	TA7511A-50	
TA7513AP	TA7513A-50	
TA7513FP	TA7513A-50	
TA7514AP	TA7513A-50	
TA7514FP	TA7513A-50	
TA7515AP	TA7515A-50	
TA7516AP	TA7515A-50	
TA7517AP	TA7515A-50	
TA7517FP	TA7515A-50	
TA7518AP	TA7515A-50	
TA7518FP	TA7515A-50	

Seat disc, jam ring, pressure seal rings, washers, O-rings, gaskets

Seat disc, jam ring, pressure seal rings, washers, O-rings, gaskets, roll pin

Seat disc, friction washer, flange packing, gaskets

Gaskets, jam ring, O-ring, pressure seal rings, seat disc, washer

Gaskets, jam ring, O-ring, pressure seal rings, roll pin, seat disc washer



A7513AP



A7505AP



A7508AP

**Replacement Bonnet Assembly**

PART NUMBER	KIT NUMBER	KIT CONTENTS
A7505AP	7505A-20	Complete Bonnet Assembly
A7506AP	7505A-20	Complete Bonnet Assembly
A7507AP	7507A-20	Complete Bonnet Assembly
A7508AP	7507A-20	Complete Bonnet Assembly
A7809BP	7509B-20	Complete Bonnet Assembly
A7510BP	7509B-20	Complete Bonnet Assembly
A7511AP	7511A-20	Complete Bonnet Assembly
A7512AP	7511A-20	Complete Bonnet Assembly
A7513AP	7513A-20	Complete Bonnet Assembly
A7514AP	7513A-20	Complete Bonnet Assembly
A7513FP	A7513F-20	Complete Bonnet Assembly
A7514FP	A7513F-20	Complete Bonnet Assembly
A7517AP	A7515-20	Complete Bonnet Assembly
A7518AP	A7515-20	Complete Bonnet Assembly
A7517FP	A7515-20	Complete Bonnet Assembly
A7518FP	A7515-20	Complete Bonnet Assembly

## RegO Repair Kits

REGO PART NUMBERS	REPAIR KITS AVAILABLE	CONTENTS	INSTRUCTION SHEET NUMBER
901 Series	903-50	Bonnet stem seat disc assembly; large hand-wheel; self-tapping screw.	903-300
	903-51	Bonnet stem seat disc assembly; small hand-wheel; self-tapping screw.	
A2141A6 & A2141A6L	A2141A6-50	O-Ring seal for female connector	A2141A-302
	A2141A6M	Male connector	
A2141A8 & A2141A8L	A2141A8-50	O-Ring seal for female connector	
	A2141A8M	Male connector	
A2141A10	A2141A10-50	O-Ring seal for female connector	A2141A-303
	A2131A10M	Male connector	
A2141A16	A2141A16-50	O-Ring seal for female connector	
	A2141A16M	Male connector	
3121	3121-50	Hand wheel; screw; o-rings(2); bonnet gasket; bleeder stem	3121-300
A3209D Series	A3209D-50	Wear button; retaining ring; main stem bearing; washer; jam ring pressure seal rings (2); main stem retaining ring; hex screw; poppet assembly; seat disc	A3209D-301
	A3209D-50T	Torsion Spring & Washer A3209D-303	A3209D-303
A3212R Series	A3212R-50	Gasket; spring; seal housing gasket; jam ring; pressure seal ring (2); o-ring; retaining ring; wear button; poppet assembly; o-ring; roll pin; cotter pin	A3212R-301
	A3213A-80	Pivot Shaft Repair - Jam ring, Pressure seal ring (2), o-ring	A3213A-302
A3213R Series	A3213R-50	Gasket; spring; seal housing gasket; jam ring; pressure seal ring (2); o-ring; ring; pressure seal ring (2); o-ring; retaining ring; wear button; poppet assembly; o-ring; roll pin; cotter pin	A3213R-301
	A3212A-80	Pivot Shaft Repair - Jam ring, Pressure seal ring (2), o-ring	A3212A-302
A3217A Series	A3217A-80G	Gasket; spring; seal housing gasket; jam ring; pressure seal ring (2); o-ring; ring; pressure seal ring (2); o-ring; retaining ring; wear button; poppet assembly; o-ring; roll pin; cotter pin	A3217A-302
	A3217F-50	Gasket; spring; seal housing gasket; jam ring; pressure seal ring (2); o-ring;	A3217F-300
A3219FA Series	A3219FA-80G	Bumper; cotter pins (3); dirt seal; inner and outer stem bearing; lever release spring; main seat disc; poppet seat disc; pivot pin locknut; poppet bearing; seal gland gasket; seat seal o-ring; stem; jam ring; stem o-ring; stem seal rings (3); stop screws; upper and lower flange seal gaskets	A3219FA-303G
6010	6010-50	Spring washer (2); gasket (main seat) gasket (flange); pressure seal ring (2); jam ring; washer (teflon); spring lock washer; rubber boot; o-ring; cotter pin (2)	6010-303
	6010-80	Pressure seal ring (2); jam ring; washer; spring (seal housing); o-ring	6010-303
AA6010	AA6010-50	Spring washer (2); sleeve insert (shaft) washer; spring (seal housing); jam ring; pressure seal ring (2); o-ring; gasket (flange); rubber boot;	6010-303
	AA6010-80	Pressure seal ring (2); jam ring; washer; spring (seal housing); o-ring	6010-303
6016	6016-50	Spring washer (2); gasket (main seat) gasket (flange); pressure seal ring (2); jam ring; washer (teflon); spring lock washer; rubber boot; o-ring; cotter pin (2)	6010-303
	6016-80	Pressure seal ring (2); jam ring; washer; spring (seal housing); o-ring	6010-303
AA6016	AA6016-50	Spring washer (2); sleeve insert (shaft) washer; spring (seal housing); jam ring; pressure seal ring (2); o-ring; gasket (flange); rubber boot;	6010-303
	AA6016-80	Pressure seal ring (2); jam ring; washer; spring (seal housing); o-ring	6010-303
6024	6024-50	Spring washer (2); gasket (main seat) gasket (flange); pressure seal ring (2); jam ring; washer (teflon); spring lock washer; rubber boot; o-ring; cotter pin (2)	6024-303
	6024-80	Pressure seal ring (2); jam ring; washer; spring (seal housing); o-ring	6024-303
AA6024	AA6024-50	Spring washer (2); sleeve insert (shaft) washer; spring (seal housing); jam ring; pressure seal ring (2); o-ring; gasket (flange); rubber boot;	6024-303
	AA6024-80	Pressure seal ring (2); jam ring; washer; spring (seal housing); o-ring	6024-303
6532A & R Series 6533A & R Series 6542A & R Series 6543A & R Series Filler Valve	6542B-50	Gaskets; spring; spring guide; stem and seat disc assembly; upper body	6542B-300
	6542B-80	Gaskets; spring; spring guide; stem and seat disc assembly	



**RegO Repair Kits (cont.)**

REGO PART NUMBERS	REPAIR KITS AVAILABLE	CONTENTS	INSTRUCTION SHEET NUMBER
6532A & R Series 6533A & R Series 6542A & R Series 6543A & R Series Service Valve	19104-50	Complete bonnet assembly; bonnet assembly; hand-wheel; self tapping screw	19104-300
-	19104-80	Upper packing for 19104-50 seal rings for multibonnet only	19104-800
-	19100-50B	Complete bonnet assembly; bonnet/stem; o-ring; hand-wheel; self tapping screw	19100-300B
6555 Series Filler Valve	8555-50	Gaskets; spring; spring guide; stem & seat disc assembly; upper body	8555-300
-	8555-80	Gaskets; spring; spring guide; stem & seat disc assembly	-
6555R Series Service Valve	19104-50	Complete multibonnet assembly-bonnet assembly; hand-wheel; self tapping screw	-
-	19104-80	Upper packing for 19104-50 seal rings for multibonnet only	-
6555D Series Service Valve	1900-50B	Complete bonnet assembly; bonnet/stem; o-ring; hand-wheel; self tapping screw	9100-300B
6579	7579-50	Gaskets; spring; spring guide; stem and seat disc assembly; upper body	7579-300
-	7579-80	Gaskets; spring; spring guide; stem and seat disc assembly	7579-300A
TA7034P TA7034LP	TA7034-50	Gaskets; jam ring; o-ring; pressure seal rings; seat disc; washer	TA7034-300
7053T	7553T-50	Bonnet; gasket; lever assembly; seat retainer assembly; stem	7553T-300
-	7553T-80	Gasket; o-ring; seat disc 7553T-301	7553T-301
7141M	7141M-50	Seat disc and retainer; gasket; o-ring; retaining ring	7141M-300
7177	7177-50	Diaphragm; gasket; o-ring; seat disc; washer	-
7188	7188-50	Hydraulic fluid; o-rings; piston; spring; trip latch	7188-300
7193K-10B	7193K-50	7193K-51 assembly; adjusting screw; nut; spring; tee	-
-	7193K-51	Check body and disc assembly; gasket; nipple; tailpiece; slip washer	-
A7506AP A7506AP	A7505-50	Gaskets; jam ring; o-ring; pressure seal rings; seat disc; washer	A7505-300
A7505AP	A7505-20	Bonnet assembly	-
TA7505AP TA-7506AP	TA7034-50	Gaskets; jam ring; o-ring; pressure seal rings; seat disc; washer	TA7034-300
A7507AP	A7507-50	Gaskets; jam ring; o-ring; pressure seal rings; seat disc; washer	A7507-300
A7508AP	7507A-20	Bonnet assembly	-
TA7507AP	TA7507-50	Gaskets; jam ring; o-ring; pressure seal rings; seat disc; washer	TA7507-300
A7509BP	A7509-50	"Gaskets; jam ring; o-ring; pressure seal	-
rings; seat disc; washer"	A7509-300	-	-
A7510BP	7509B-20	Bonnet assembly	-
TA7509BP TA7510BP	TA7509B-50	Gaskets; jam ring; o-ring; pressure seal rings; seat disc; washer	TA7509B-300
A7511AP A7511FP A7512AP A7512FP	A7511-50	Gaskets; jam ring; o-ring; pressure seal rings; seat disc; washer	A7511-300
-	A7511F-20	Bonnet assembly	-
TA7511AP TA7511FP TA-7512AP TA7512FP	TA7511A-50	Gaskets; jam ring; o-ring; pressure seal rings; seat disc; washer	TA7511-300
A7513AP A7514AP	A7513-50	Gaskets; jam ring; o-ring; pressure seal rings; seat disc; washer	A7513-300
-	A7513F-20	Bonnet assembly	-
TA7513AP TA-7514AP	TA7513A-50	Gaskets; jam ring; o-ring; pressure seal rings; seat disc; washer	TA7513A-300

## RegO Repair Kits (cont.)

REGO PART NUMBERS	REPAIR KITS AVAILABLE	CONTENTS	INSTRUCTION SHEET NUMBER
-	TA7513A-20	Bonnet assembly	-
TA7513FP TA7514FP	TA7513A-50	Gaskets; jam ring; o-ring; pressure seal rings; seat disc; washer	TA7513A-300
-	TA7513F-20	Bonnet assembly	-
A7517AP A7517FP A7517AP A7518FP	A7515-50	Gaskets; jam ring; o-ring; pressure seal rings; seat disc; washer	-
-	A7515-20	Bonnet assembly	-
TA7517AP TA7518FP TA- 7517AP TA7518FP	TA7515A-50	Gaskets; jam ring; o-ring; pressure seal rings; seat disc; washer	TA7515A-300
7550P 7750UP 7551P	7550-15	Bonnet assembly	-
A7550P A7750UP A7551P	A7550-15	Bonnet assembly	-
A7553A	A7553A-50	Gaskets; jam ring; o-ring; pressure seal rings; seat disc; washer	A7553A-300
7554LV 7554LAV	7554L-20A	Bonnet assembly	-
7554SV 7554SAV	7554S-20	Bonnet assembly	-
7556VR, R Series Service Valve	19104-50	Complete multibonnet assembly; bonnet assembly; hand-wheel; self tapping screw	19104-300
-	19104-80	Upper packing for 19104-50 seal rings for multibonnet only	19104-800
-	19100-50B	Complete multibonnet assembly; bonnet assembly; hand-wheel; self tapping screw	19100-300B
7556VR, R Series Vapor Equalizing	8475-51A	Body; gaskets; spring; stem and seat disc assembly	8475-300
-	8475-81A	Gaskets; spring stem and seat disc assembly	8475-300A
7573D	7573D-81	Gaskets; spring stem and seat disc assembly	7573D-300
L7579	L7579-50	Gaskets; spring stem and seat disc assembly; upper body	7579-300
-	L7579-80	Gaskets; spring stem and seat disc assembly	7579-300A
7647S Series	7647B-80A	Gaskets; spring; seat disc retainer assembly	7647B-300A
A7704 Series A7705 Series A7706 Series	A7705-50	Flange packing; friction washer; gaskets; seat disc	A7705-300
7705P	7554-20	Bonnet Assembly	-
A7707L A7708L	A7707-50	Gaskets; groove pin; jam ring; o-ring; pressure seal rings; seat disc	A7707-300
-	A7707-75	Bonnet assembly	-
A7793A A7797A	A7797-50	Gaskets; groove pin; jam ring; o-ring; pressure seal rings; seat disc; washers	A7797-300
-	A7797A-4	Bonnet and lever assembly	-
A7853A	A7883F-50	Bleeder assembly; bushing; cap; cap screws; filters; gaskets; lock washers; needle valve kit; o-rings; retaining ring; roll pin; screen filter; seal; set screws; springs; stem assembly kit; v-ring; xseal	7883-300
-	A7883F-80	Bushing; cylinder cap screws; filters; gaskets; insert; o-rings; retaining ring; seal disc; v-ring; x-seals	7883-300
-	A7883F-150	Gaskets; seal disc; x-seal	7883-300
A7884FK	A7883F-50	Bleeder assembly; bushing; cap; cap screws; filters; gaskets; lock washers; needle valve kit; o-rings; retaining ring; roll pin; screen filter; seal; set screws; springs; stem assembly kit; v-ring; xseal	7883-300
-	A7884F-80	Bushing; cylinder cap screws; filters; gaskets; insert; o-rings; retaining ring; seal disc; v-ring; x-seals	7883-300
-	A7884F-150	Gaskets; seal disc; x-seal	7883-300
TA7894P	TA7894-50	Gaskets; jam ring; o-ring; pressure seal rings; seat disc; washer	TA7894-300
7901 Series	7901T-50	Bonnet assembly; gasket; lever	7901-300

**RegO Repair Kits (cont.)**

REGO PART NUMBERS	REPAIR KITS AVAILABLE	CONTENTS	INSTRUCTION SHEET NUMBER
-	7901-80	Gasket; o-ring seat disc retainer assembly	7901-301
A8016DP, A8016DCB, A8017DP, A8017DLP, A8018DP	A8016B-50	Gaskets; jam ring; o-ring; pressure seal rings; seat disc; washer	A8016B-300
-	A7507A-20	Bonnet assembly	-
A8017DH	A8017BH-20R	Bonnet and stem assembly	A8017BH-300
8475 8477	8475-50L	Filler valve extension assembly	8475-300L
G8475RL G8475RLW Filler Valve	8475L-50	Upper body; gaskets; seat disc & retainer assembly; spring	8475-300F
-	8475L-80	Gaskets; seat disc & retainer assembly spring	-
G8475RL G8475RLW Valor Equalizing Valve	8475-51A	Body; gaskets; spring; stem & seat disc assembly	8475-300
-	8475-81A	Gaskets; spring & stem seat disc assembly	8475-300A
G8475RL G8475RLW Ser- vice Valve	19104-50	Complete multibonnet assembly-bonnet assembly; hand-wheel; self tapping screw	19104-300
-	19104-80	Upper packing for 19104-50 seal rings for multibonnet only	19104-800
-	19100-50B	Complete bonnet assembly; bonnet/stem; oring; hand-wheel; self tapping screw	19100-300B
G8475RL G8475RLW Fixed Liquid Level Gauge	3165C	Fixed liquid level gauge valve	-
8542G / 8542AG AA8542UA Series	8540-50	Bleeder valve assemblies; packing gland; set screw; washer; key	8540-300
8555D/R Series Mfg'd 10/90 or before Filler Valve	6542B-50	Gaskets; spring; spring guide; stem & seat disc assembly; upper body	6542B-300
-	6542B-80	Gaskets; spring; spring guide; stem & seat disc assembly	-
8556 Service Valve	19101-50	Bonnet ,O-Ring, and Stem Assembly - Handwheel & Screw	19100-300B
8555D Service Valve	19100-50B	Complete bonnet assembly; bonnet stem; o-ring; hand-wheel; self tapping screw	19100-300B
8555DL Filler Valve	6542B-50	Gaskets; spring stem and seat disc assembly; upper body	6542B-300
-	6542B-80	Gaskets; spring stem & seat disc assembly	-
8555DL Service Valve	19100-50B	Complete bonnet assembly; bonnet stem; o-ring; hand-wheel; self tapping screw	19100-300B
8555R Service Valve	19104-50	Complete multibonnet assembly-bonnet assembly; hand-wheel; self tapping screw	19104-300
-	19104-80	Upper packing for 19104-50 seal rings for multibonnet only	19104-800
8555D/R Series Mfg'd after 10/90 Filler Valve	8555-50	Gaskets; spring; spring guide; stem & seat disc assembly; upper body	8555-300
-	8555-80	Gaskets; spring; spring guide; stem & seat disc assembly	-
A/AA8560 Series A/AA8570 Series	8560-50	Bleeder valve assemblies; seat ring assemblies; pressure seal rings; packing gland; jam ring; washer; gaskets	7564-300
8593AL Filler Valve	8475L-50	Upper body; gaskets; seat disc & retainer assembly; spring	8475-300F

## RegO Repair Kits (cont.)

REGO PART NUMBERS	REPAIR KITS AVAILABLE	CONTENTS	INSTRUCTION SHEET NUMBER
-	8475L-80	Gaskets; seat disc & retainer assembly; spring	-
8593AL Vapor Equalizing Valve	8475-51A	Body; gaskets; spring; stem & seat disc assembly	8475-300
-	8475-81A	Gaskets; spring stem & seat disc assembly	8475-300A
8593AL Service Valve	19104-50	Complete multibonnet assembly-bonnet assembly; hand-wheel; self tapping screw	19104-300
-	19104-80	Upper packing for 19104-50 seal rings for multibonnet only	19104-800
-	19100-50B	Complete bonnet assembly; bonnet stem; o-ring; hand-wheel; self tapping screw	19100-300B
9101P Series (Forklift Service Valve)	19101-50	Complete bonnet assembly; bonnet stem; o-ring; smaller hand-wheel; self tapping screw	19101-300
9101C, D, H, R, Y Series Service Valve	19104-50	Complete multibonnet assembly-bonnet assembly; hand-wheel; self tapping screw	19104-300
-	19104-80	Upper packing for 19104-50 seal rings for multibonnet only	19104-800
-	19100-50B	Complete bonnet assembly; bonnet stem; o-ring; hand-wheel; self tapping screw	19100-300B
9101C, D, Series Service Valve	19104-50	Complete multibonnet assembly-bonnet assembly; hand-wheel; self tapping screw	19104-300
-	19104-80	Upper packing for 19104-50 seal rings for multibonnet only	19104-800
-	19100-50B	Complete bonnet assembly; bonnet stem; o-ring; hand-wheel; self tapping screw	19100-300B
9102D Series	19101-50B	Complete bonnet assembly; bonnet/stem; o-ring; hand-wheel; self tapping screw	19100-300B
9102R Series	19104-50	Complete multibonnet assembly-bonnet assembly; hand-wheel; self tapping screw	19104-300
-	19104-80	Upper packing for 19104-50 seal rings for multibonnet only	19104-800
9103T9F Service Valve	19101-50B	Complete bonnet assembly; bonnet/stem; o-ring; hand-wheel; self tapping screw	19100-300B
9104 Series	19100-1BXV	Bonnet, O-Ring & Stem Assembly	-
9106CO	903-50	Bonnet stem seat disc assembly; large hand-wheel; self tapping screw	-
-	903-51	Bonnet stem seat disc assembly; small hand-wheel; self tapping screw	-
9107K8 Series	19100-50B	Complete bonnet assembly; bonnet/stem; o-ring; hand-wheel; self tapping screw	19100-300B
9300Y/R	19104-50	Complete multibonnet assembly-bonnet assembly; hand-wheel; self tapping screw	19104-300
-	19104-80	Upper packing for 19104-50 seal rings for multibonnet only	19104-800
-	19100-50B	Complete bonnet assembly; bonnet stem; o-ring; hand-wheel; self tapping screw	19100-300B

AVERAGE PROPERTIES OF PROPANE	
Formula	C3H8
Boiling Point	-44 °F
Specific Gravity of Gas (Air = 1.00)	1.50
Specific Gravity of Liquid (Water = 1.00)	0.51
Lbs. per Gallon of Gas at 60°F	4.24
BTU per Gallon of Liquid at 60°F	91547
BTU per Lb. of Gas	21591
BTU per Cu. Ft. of Gas at 60°F	2516
Cu. Ft. of Vapor at 60°F/Gal. of Liquid at 60°F	36.39
Cu. Ft. of Vapor at 60°F/Lb. of Liquid at 60°F	8.547
Latent Heat of Vaporization at Boiling Point BTU/Gal.	785.0
Combustion Data: Cu. Ft. Air Required to Burn 1 Cu. Ft. Gas	23.86
Ignition Temperature in Air	920- 1120°F
Maximum Flame Temperature in Air	3595°F
Limits of Imflammability, Percentage of Gas in Air Mixture: at Lower Limit at Upper Limit	2.15% 9.6%
Octane Number (ISO - Octane = 100)	Over 100

BTU COMPARISON		
COMMON FUELS	PER GAL.	PER LB.
Propane	91,547	21,591
Butane	102,032	21,221
Gasoline	110,250	20,930
Fuel Oil	134,425	16,960

TEMPERATURE CONVERSION			
DEG. F	DEG. C.	DEG. F	DEG. C
-50	-46	60	15.6
-40	-40	70	21.1
-30	-34	80	26.7
-20	-29	90	32.2
-10	-23	100	37.8
0	-17.8	110	43
+10	-12.2	120	49
20	-6.7	130	54
30	-1.1	140	60
32	0	150	66
40	+4.4	160	71
50	10.0	170	77

CONVERSION UNITS (LENGTH)		
MULTIPLY:	BY:	TO OBTAIN:
Meters	0.3937	inches
Miles (nautical)	0.3048	centimeters
Miles (statute)	304.8	millimeters
Yards	0.6214	miles
Yards	1.094	grams

APPROXIMATE VAPORIZATION CAPACITIES OF TRINITY PROPANE TANKS		
BTU PER HOUR WITH 40% LIQUID IN TANK DOMESTIC SYSTEMS		
TANK SIZE WATER CAPACITY	PREVAILING AIR TEMPERATURE	
	20°F	60°F
120	290,304	290,304
250	406,080	721,920
325	514,100	937,900
500	634,032	1,127,168
1,000	1,088,472	1,978,051
2,000	2,128,897	4,257,795
6,000	4,262,400	6,393,600
8,000	5,060,000	7,590,000
10,000	6,230,400	9,345,600
12,000	7,400,000	11,100,000
15,000	8,080,000	11,120,000
18,000	8,500,000	12,120,000
20,000	9,500,000	14,250,000
30,000	11,800,000	17,700,000

CONVERSION UNITS (PRESSURE)		
MULTIPLY:	BY:	TO OBTAIN:
Grams per sq. cm	0.0142	pounds per sq. in.
Inches of mercury	0.4912	pounds per sq. in.
Inches of mercury	1.133	feet of water
Inches of water	0.0361	pounds per sq. in.
Inches of water	0.0735	Inches of mercury
Inches of water	0.5781	ounces per sq. in.
Inches of water	5.204	pounds per sq. ft.
KPA	100	BAR
Kilograms per sq. cm	14.22	pounds per sq. in.
Kilograms per sq. m	0.2048	pounds per sq. ft.
Pounds per sq. in.	0.07031	kg per sq. cm.
Pounds per sq. in.	0.06804	atmospheres
Pounds per sq. in.	6.89	KPA
Pounds per sq. in.	2.036	Inches of mercury
Pounds per sq. in.	2.307	feet of water
Pounds per sq. in.	0.6897	BAR
Pounds per sq. in.	27.67	inches of water

CONVERSION UNITS (LENGTH)		
MULTIPLY:	BY:	TO OBTAIN:
Centimeters	0.3937	inches
Feet	0.3048	centimeters
Feet	304.8	millimeters
Kilometer	0.6214	miles
Meters	1.094	grams
Meters	3.281	kilograms

CONVERTING VOLUMES OF GAS (CFH TO CFH OR CFM TO CFM)		
MULTIPLY FLOW OF:	BY:	TO OBTAIN FLOW OF:
Air	0.707	Butane
	1.290	Natural Gas
	0.808	Propane
Butane	1.414	Air
	1.826	Natural Gas
	1.140	Propane
Natural Gas	0.775	Air
	0.547	Butane
	0.625	Propane
Propane	1.237	Air
	0.874	Butane
	1.598	Natural Gas

CONVERSION UNITS (VOLUME)		
MULTIPLY:	BY:	TO OBTAIN:
Cubic Centimeter	0.06103	cubic inches
Cubic Feet	0.0275	gallons (US)
Cubic Feet	28.316	liters
Cubic Feet	1728	cubic inches
Gallons (US)	36.39	cubic feet
Gallons (US)	3.785	liters
Gallons (US)	231	cubic inches
Liters	1.057	quarts
Liters	2.113	pints

CONVERSION UNITS (MISCELLANEOUS)		
MULTIPLY:	BY:	TO OBTAIN:
BTU	0.252	calories
Decitherm	10,000	BTU
Kilogram	2.205	pounds
Kilowatt Hour	3412	BTU
Ounces	28.35	grams
Pounds	0.4536	kilograms
Pounds	453.5924	grams
Pounds	21,591	LPG BTU
Therm	100,000	BTU
API Bbls	42	gallons (US)
Gallons of Propane	26.9	KWH
HP	746	KWH
HP (Steam)	42,418	BTU

VAPOR PRESSURE OF PROPANE							
TEMP.	PRES.	TEMP.	PRES.	TEMP.	PRES.	TEMP.	PRES.
110°F	220 psig	60°F	102 psig	20°F	47 psig	-20°F	13.5 psig
100°F	196 psig	50°F	86 psig	10°F	37 psig	-30°F	8 psig
90°F	165 psig	40°F	72 psig	0°F	28 psig	-40°F	3.6 psig
80°F	140 psig	30°F	58 psig	-10°F	23.3 psig	-44°F	0 psig
70°F	127 psig	-	-	-	-	-	-



You'll find cylinder accessories on page 70.



## Manchester Portable DOT Vertical Steel Cylinders

### 5, 10, and 11 Pound Portable Cylinders



DESCRIPTION	PART NUMBER	OL	H	D	TW	WC	B
5LB Vertical ACME/Type 1 w. OPD	10054	12	8.62	8	9.5	13	6.5
10LB Vertical ACME/Type 1 w. OPD	10228.4	17.43	13.75	8.87	14	26.1	7.25
11LB Vertical ACME/Type 1 w. OPD	10393.1	12.38	8.37	12.16	13	25.4	7.93

## Manchester Portable DOT Vertical Steel Cylinders

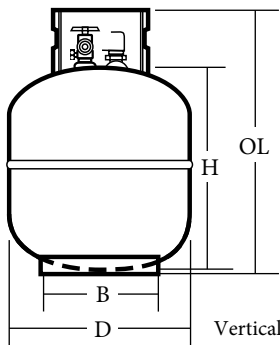

### 20 Pound Gas Grill and RV Cylinders

DESCRIPTION	PART NUMBER	OL	H	D	B	TW	WC
20LB Vertical ACME/Type 1 w. OPD	10504	17.56	13.62	12.16	8	18	47.6
20LB Vertical ACME/Type 1, Gauge w. OPD	10834TC.1	17.56	13.62	12.16	8	19	47.6
20LB Telephone, ACME/Type 1 w. OPD	10781.2	18.31	13.62	12.16	7.93	20	47.6

### 30 and 40 Pound Cylinders

DESCRIPTION	PART NUMBER	OL	H	D	B	TW	WC
30LB ACME/Type 1 w. OPD	1160.8	23.43	19.56	12.16	7.93	25.5	71.4
30LB ACME/Type 1, Gauge w. OPD	1166.2	23.43	19.56	12.16	7.93	26.6	71.4
40LB ACME/Type 1 w. OPD	1220TC.4	29.43	25.56	12.16	7.93	30.5	95.2
40LB ACME/Type 1, Gauge w. OPD	1222TC.4	29.43	25.56	12.16	7.93	30.5	95.2
40LB Telephone, ACME/Type 1 w. OPD	12781.2	31.06	25.56	12.16	12.16	34	95.2
40LB ACME/Type 1, w. OPD (Large Foot Ring)	1203TC.3	29.43	25.56	12.16	12	30.5	95.2

Cylinders are manufactured to meet or exceed DOT Specification 4BA240 or 4BW240.

**Manchester Portable DOT Vertical Steel Cylinders**

50, 60 and 100 Pound Cylinders

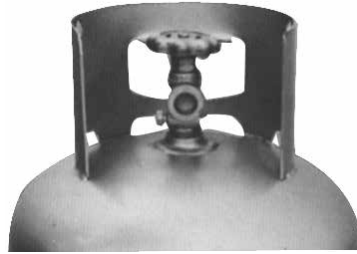
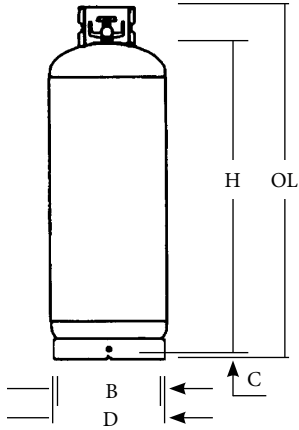

Standard POL Valve  
CGA510 Connection



Footing Powder Coated

DESCRIPTION	PART NUMBER	C	OL	H	D	B	TW	WC
50LB Outage, Collar Type with POL	14861	.50	28.5	23.7	14.5	14	46	119
60LB Outage, Collar Type with POL	1426	1.06	43.12	37.37	12.16	12.16	46	143
100LB Outage, Collar Type with POL	1428	.50	46.31	41	15.06	14	70	238
100LB Multivalve, Collar Type with POL White	1436.4	.50	46.31	41	15.06	14	71	238
100LB Cyl Collar w. liquid valve	100SLM	.50	46.31	41	15.06	14	71	238
100LB Cyl Collar w. liquid multivalve	100SLMM	.50	46.31	41	15.06	14	238	14



1436.4  
Vapor Multivalve  
POL Valve with  
1 3/4" ACME Fill



100SLM  
Liquid Withdrawal Valve  
CGA555 Connection



100SLMM  
Liquid Withdrawal Multivalve  
CGA555 Connection  
with 1 3/4" ACME Fill

*All cylinders on this page are manufactured to meet or exceed DOT Specification 4BW240.*

## Tank and Cylinder Accessories



Screw On Cap  
1433



Screw On Collar  
1406.1  
1406.2

For use on cylinders during transportation. Also protects valve on construction sites as per DOT and OSHA requirements.

PART NUMBER	DESCRIPTION
1433	Screw cap, 3 1/2" thread
1406.1	Screw on collar (construction) fits over multivalve 3 1/2"
1406.2	Screw on collar (construction) fits over multivalve 3 1/8"

## Locks

The easy to install 510 Saf-T-Lok securely locks POL service valves to prevent unauthorized hookups, reduce pilferage, and secures tanks after "out of gas" calls. Provides an effective credit control.

PART NUMBER	DESCRIPTION
510	POL-LOCK
510-K	POL-LOCK KEY
B531G & B827P-A0	POL Lock complete with lock and plug for LP outlet valve keyed alike (key not included)
S502K-C-BLUE	Key (when ordered with lock order) cut uniquely with coe for each company
S533G-LLVC-A0	1 3/4" ACME valve cap lock with brass cap and slip ring with lock keyed alike (key not included)



## Locking Caps

Encloses ACME thread or handwheel on valve to prevent tampering.

PART NUMBER	INSIDE DIAMETER	BOTTOM OPENING	HEIGHT	VALVE TYPE
MSCP-MLC-1	2 1/4"	1 1/2"	1 1/8"	FILLER
MSCP-MLC-S4	2 1/2"	1 3/8"	1"	100LB



MSCP-MLC-1



MSCP-MLC-S4

## Break-away Locks

Hidden breakaway feature allows fire department or emergency response personnel access to valves, plant gates, etc. Lock shackle breaks away when struck with a hammer or chisel.

PART NUMBER	DESCRIPTION
500BRK	Break-away Lock; Keyed Alike

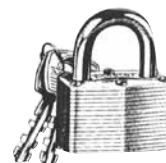



**Special Application Cylinders**



**Vertical Liquid Truck Cylinders**

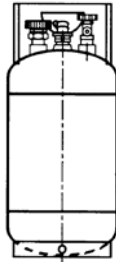

VAPOR OR LIQUID  
14 LB

ORDER NUMBER	5305L	5306V
	14LB LP WITH FILL (LIQUID SERVICE)	14LB LP (VAPOR SERVICE)
Water Capacity (lbs.)	32.4	32.4
OAL	20.75	20.75
Cyl. Diameter	9.0	9.0
Guard Diameter	8.0	8.0
Foot Ring Diameter	8.0	8.0
Tare Weight, lbs.*	21.8	21.8

\* Tare weight may vary slightly on individual cylinder.

\*\* Special order

**Lawn Mower Cylinder**

PART NUMBER	DESCRIPTION	WATER CAPACITY	LENGTH	HEIGHT	DIAMETER	TARE-WEIGHT
9367	33.5lb. Mower Cylinder	80 gal	22.4"	28.3"	12"	25 lb
9368	43.5lb. Mower Cylinder	104 gal	28.8"	34.4"	12"	26 lb

**Manchester DOT Horizontal Cylinders**

**20 and 30 Pound Steel Cylinders**

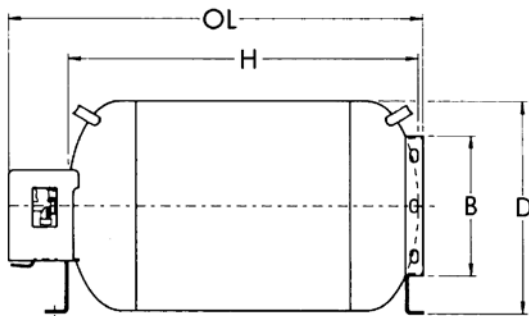

DESCRIPTION	PART NUMBER	OL	H	D	TW	WC	B
20LB ACME/Type 1, Gauge with OPD	10487TC	17.37	13.62	12.16	19.5	47.6	7.93
30LB ACME/Type 1 with OPD and Gauge	1175TC	23.43	19.56	12.16	27.7	71.4	7.93

All cylinders on this page are manufactured to meet or exceed DOT Specification 4BA240 or 4BW240.

## Portable DOT Aluminum Cylinders

### 6, 10, 20, 30 and 40 Pound Vertical Aluminum Cylinders

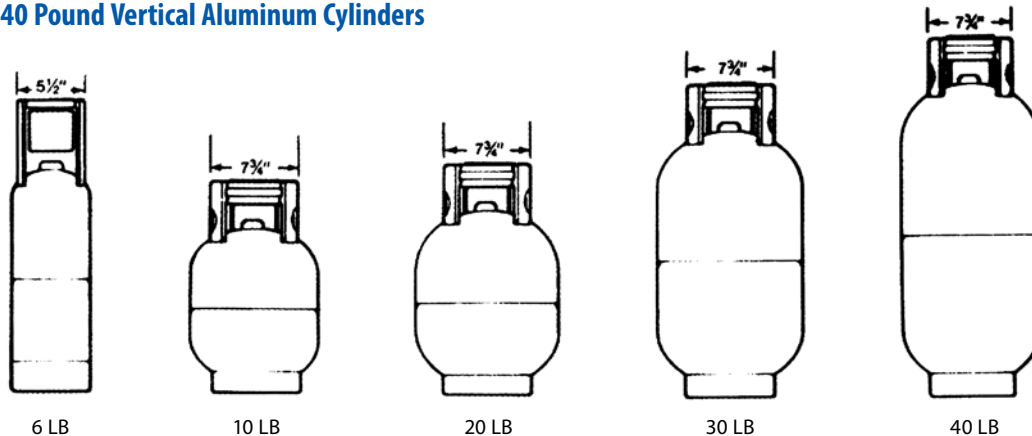

DESCRIPTION	PART NUMBER	OL	H	D	TW	WC
10LB Vertical ACME/Type 1	9058TC.2	16.25	10.75	10.28	10.1	23.8
20LB Vertical ACME/Type 1	9060TC.1	20.06	15.1	12.125	14.1	47.6

### 10 and 20 Pound Horizontal Aluminum Cylinders

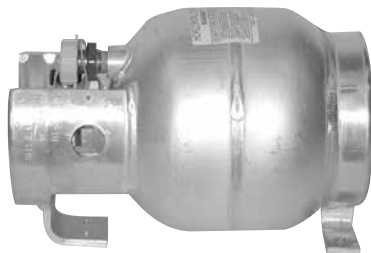

DESCRIPTION	PART NUMBER	OL	OH	WC
10LB Horizontal with OPD	9059TC.1	16.5	11	23.8
20LB Horizontal with OPD	9061TC.1	20.56	13	47.6

All cylinders above are manufactured to meet or exceed DOT Specification 4E240.

## Propane Mower Cylinders

### Features:

- Cylinders available for horizontal or vertical service, depending on application
- Standard fittings include: Safety Relief, Float Gauge, Fixed Liquid Level, Vapor Service, and ACME Fill Valves
- Collar painted green for product differentiation



PART NUMBER	DESCRIPTION	TYPE	WATER CAPACITY	LENGTH	HEIGHT	DIAMETER	TARE-WEIGHT
5456TC.3	20lb.	Steel	4.76 gal	13.6"	19"	12"	27 lb
9366	20lb.	Aluminum	4.76 gal	20.4"	14.6"	12"	17 lb
9367	33.5lb.	Aluminum	8.0 gal	22.4"	28.3"	12"	25 lb
9368	43.5lb.	Aluminum	10.4 gal	28.8"	34.4"	12"	26 lb



Remember! All Manchester forklift tanks have a lifetime guarantee on the liquid tube.

## Manchester Aluminum Forklift Cylinders

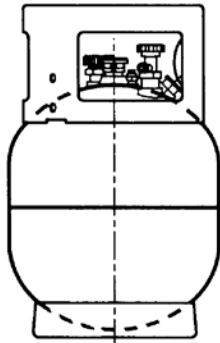

20 LB

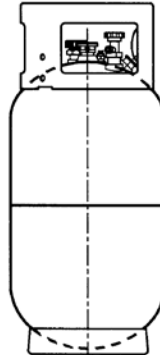

33.5 LB

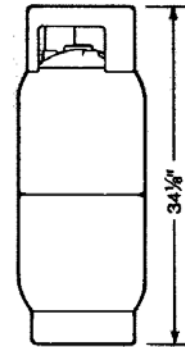

43.5 LB

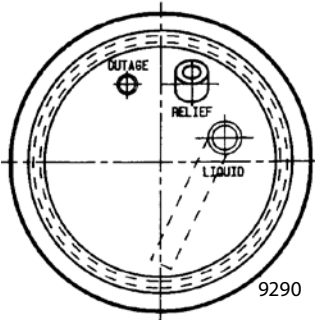

9290

3 Hole Head  
No Gauge

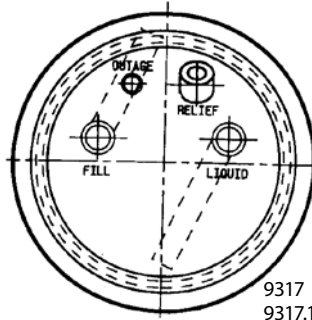

9317  
9317.12\*

4 Hole Head  
No Gauge

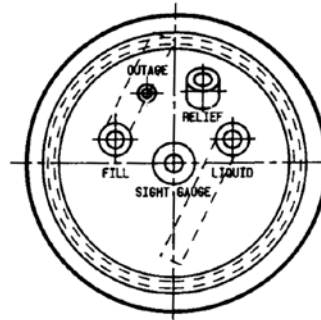

5 Hole Head  
Code 12

43ALFL12W  
9161  
9305  
9315

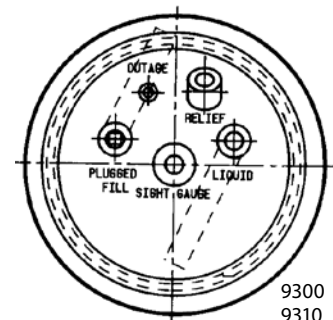

9300  
9310  
9164

5 Hole Head  
Plugged Fill  
Code 13

PART NUMBER	LP CAP	OVER-ALL LENGTH	CYL DIAM.	GUARD DIAM.	FOOTRING DIAM.	TARE WT (LBS)	GAUGE	ACME CONN	WATER CAP (LBS)	ACME FAST FILL	10% OUTAGE
9285 Buffer/Vapor**	20LB	20.38	12.28	10.5	9.5	17	Yes	Yes	47.6	No	Yes
9287 Buffer/Vapor**	20LB	20.38	12.28	10.5	9.5	17	Yes	Yes	47.6	Yes	Yes
9305	20LB	20.38	12.28	10.5	9.5	17	Yes	Yes	47.6	Yes	Yes
9310	33.5LB	28.56	12.28	10.5	9.5	23.5	Yes	Yes	80	No	Yes
9315	33.5LB	28.56	12.28	10.5	9.5	23.5	Yes	Yes	80	Yes	Yes
9290	33.5LB	28.56	12.28	10.5	9.5	23.5	No	Yes	80	No	Yes
9317	33.5LB	28.56	12.28	10.5	9.5	23.5	No	Yes	80	Yes	Yes
9161	43.5LB	33.94	12.28	10.5	9.5	25	Yes	Yes	105	Yes	Yes
9164	43.5LB	33.94	12.28	10.5	9.5	25	Yes	Yes	105	No	Yes

NOTE: We are the largest warehouse for forklift cylinders. We can stamp your name on the collar.

\* Has a plugged fill opening.

\*\* Buffer tanks are for use in vertical position only.

All cylinders on this page are manufactured to meet or exceed DOT Specification 4E240.

## Manchester Steel Forklift Cylinders

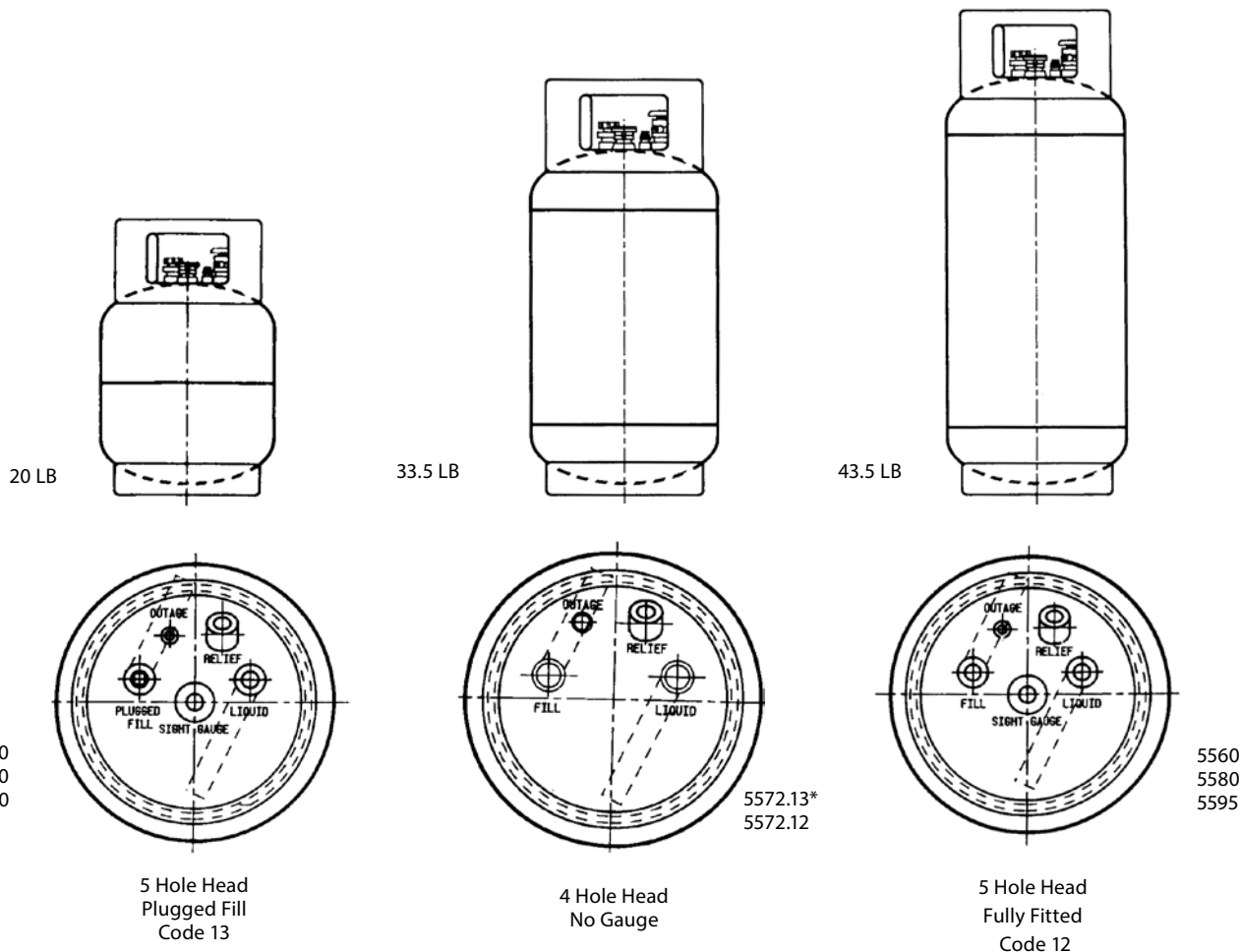

PART NUMBER	LP CAP	OVERALL LENGTH	CYL DIAM.	GUARD DIAM.	FOOTRING DIAM.	TARE WT (LBS)	GAUGE	ACME CONN	WATER CAP (LBS)	ACME FAST FILL	10% OUTAGE
5455 Buffer/Vapor	20LB	19.13	12.19	10.25	10.25	27	Yes	Yes	47.6	No	Yes
5456 Buffer/Vapor	20LB	19.13	12.19	10.25	10.25	27	Yes	Yes	47.6	Yes	Yes
5550	20LB	19.13	12.19	10.25	10.25	27	Yes	Yes	47.6	No	Yes
5560	20LB	19.13	12.19	10.25	10.25	27	Yes	Yes	47.6	Yes	Yes
5570	33.5LB	27.25	12.19	10.25	10.25	36	Yes	Yes	80	No	Yes
5580	33.5LB	27.25	12.19	10.25	10.25	36	Yes	Yes	80	Yes	Yes
5590	43.5LB	33.25	12.19	10.25	10.25	43	Yes	Yes	104	No	Yes
5595	43.5LB	33.25	12.19	10.25	10.25	43	Yes	Yes	104	Yes	Yes

NOTE: We are the largest warehouse for forklift cylinders. We can stamp your name on the collar.  
\* Has plugged fill opening.

*All cylinders on this page are manufactured to meet or exceed DOT Specification 4BA240.*

## RegO Service Valves for Dot Forklift Cylinders



9101P5

Designed specifically for vapor or liquid withdrawal service on DOT forklift containers. Valves with 1.5 GPM closing flow are for use in small and medium size lift truck applications, while those with 2.6 GPM closing flow are for large lift trucks and gantry crane type vehicles.

PART NUMBER	CONTAINER CONNECTION	SERVICE CONNECTION	LIQUID WITHDRAWAL CONNECTION	CLOSING FLOW (LP-GAS) VAPOR			APPROXIMATE FILLING RATE LIQUID FLOW, GPM PRESSURE DROP ACROSS VALVE			
				25 PSIG INLET (SCFH)	100 PSIG INLET (SCFH)	LIQUID (GPM)	10 PSIG	25 PSIG	50 PSIG	100 PSIG
9101P5	3/4" M. NGT	3/8" M. NPT	None	430	900	1.5	5.0	7.6	10.7	14.9
9101P5HT	3/4" M. NGT	3/8" M. NPT	None	550	1050	2.6	5.0	7.6	10.7	14.9
9101P6	3/4" M. NGT	3/8" M. NPT	1/4" NPT	430	900	1.5	4.5	7.2	10.3	14.8
9101P6H	3/4" M. NGT	3/8" M. NPT	1/4" NPT	550	1050	2.6	4.5	7.2	10.3	14.8

NOTE: These valves incorporate an excess flow valve.

## Forklift & Mower Connectors

These brass connectors are especially designed to join the carburetor fuel line to the service valve on lift truck cylinders.



7141M



7141F

PART NUMBER	APPLICATION	TYPE	INLET	OUTLET	PROTECTIVE CAP*	
					RUBBER	BRASS
7141M	Service Valve	Forklift	3/8" F.NPT	1 1/4" M. ACME	7141M-40	7141FP
7141F	Fuel Line	Forklift	1 1/4" F.ACME	1/4" F.NPT	-	-
V21502	-	Mower	-	-	-	-
V21503	-	Mower	-	-	-	-

### Accessories

PART NUMBER	DESCRIPTION
7141M-3R	RegoO Outer Flat Washer
MSW-4	Outer Washer Flat
2114A	Inner O-Ring

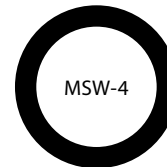

## Fixed Liquid Level Gauges

PART NUMBER	DESCRIPTION
3165CF05.6	12" Tube Supplied
3165C	Fixed Level Gauge
3162C-6	Thumb Screw Plug



3165CF05.6

## RegO Double Backcheck Filler Valve

1 3/4" M. ACME x 3/4" MPT high capacity filling used on DOT and ASME containers for fast filling.



MSCP-M3274-9P



7647SCT  
with everseal on threads

## Cabinets

### Construction

- All welded construction. No nuts and bolts to come loose.
- 1 1/2" angle frame.
- 1" angle shelves.
- 16 gauge steel roof.
- 16 gauge expanded metal sides and doors.

### Features

- Lockable T-handle plus hasp for padlock.
- Tapered shelf front for easy cylinder placement.
- Heavy duty tubular hinge welded to frame and door.

### 33# Motor Fuel Cylinder Storage Cabinets – The "M" Series

Painted safety yellow rust inhibitor and includes 3 safety decals.

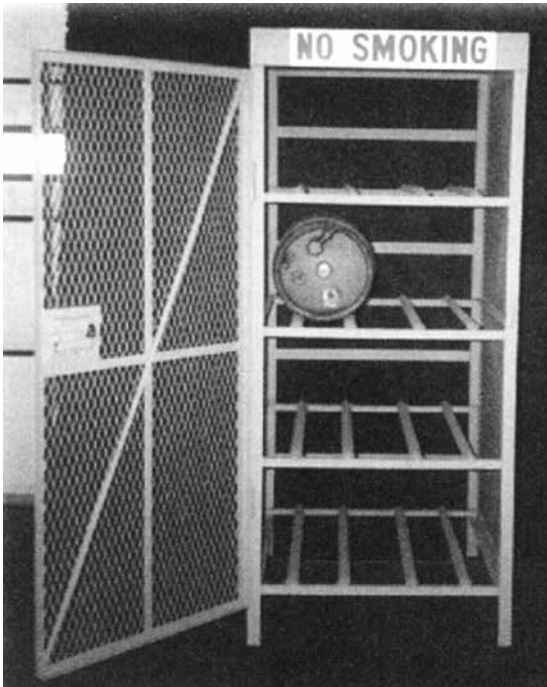

### 20# Cylinder Storage Cabinets – The "X" Series

Powder coated white. Other colors available and includes 2 safety decals plus place for sign. Sign not included.



PART NUMBER	NO. CYLS	DEEP	WIDE	HIGH
M-4	4	37"	30"	40"
M-6	6	37"	30"	55"
M-8	8	37"	30"	70"
M-12	12	37"	43"	70"
M-16	16	37"	60"	70"
M-24	24	37"	85"	70"

PART NUMBER	NO. CYLS	DEEP	WIDE	HIGH
X-8	8	27"	30"	50"
X-12	12	27"	43"	50"
X-16	16	27"	60"	50"
X-18	18	27"	43"	72"
X-24	24	27"	60"	72"
X-24L	24 (low profile)	27"	85"	50"
X-36	36	39"	50"	72"

## Relief Valves



PART NUMBER	DESCRIPTION
8545AKT	3/4" NPT Relief 375PSI
MSCP-M895090-10	45° Pipe Away Adapter
MSCP-M8545-10	90° Pipe Away Adapter
7545-40	Rain Cap w/ Strap for 8545AK
9103-54	Raincap for 7545-14
3100-54	Cap for Relief Valve 8555 Series

## Forklift Cylinder Brackets



PART NUMBER	CYLINDER SIZE	DESCRIPTION
TB-2	33 1/2 LB & 43 1/2 LB	Horizontal
TB-3	20 LB 33 1/2 LB	Vertical
TB-B	14 LB	Vertical
TB-6	14 LB	Horizontal
TB2-60	Any	Toggle Latch Only

## Replacement Dials For Rochester Float Gauges



PART NUMBER	DIAL SIZE	TYPE OF TANK
5-01791	Junior	33LB Universal

## Taylor Visible Replacement Dials



PART NUMBER	DESCRIPTION
2733U-CV	JR Universal 33LB Motor Fuel
2743U-CV	JR Universal 43LB Motor Fuel

## Screws and Gaskets

PART NUMBER	DESCRIPTION
MSCP-M40-414S	Junior Head Screw
40-415S	Senior Head Screw
40-416	Dial Screw
MSCP-15-004	Senior Gauge Gasket
MSCP-15-007	Junior Gauge Gasket



## Float Gauges for forklift Cylinders

CYLINDER SIZE	PART NUMBER	
	JR. GAUGES	1 1/4" MPT
33 1/2 LB	JU160B	TU160B
43 1/2 LB	JU212A	TU212A

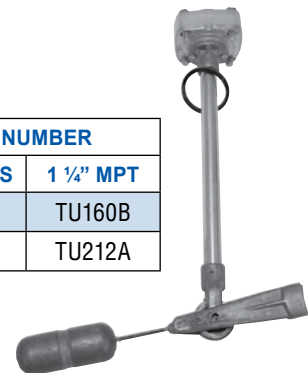



*Did you know we have many remote pick-up yards where you can get a tank in a hurry? Call for the locations nearest you.*

## Manchester DOT Cylinders

**Manchester ASME and DOT 200 and 420 offer the best finish and features in the industry.**

- Large 16" Diameter Collar
- Large Vented Collar & Foot Ring
- Full Load Lift-Lugs
- Armor-Clad III Powder Coat Paint
- All Threads Sealed with Blue Everseal
- Heavy-Duty Hinged Lid
- 4 Hole Head Design
- HPPE Plastic Lids – No Rust or Dents
- Colors Available
- Vacuum Pre-purged

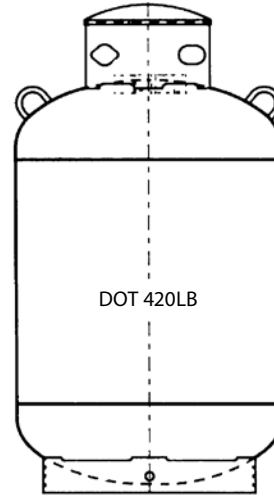
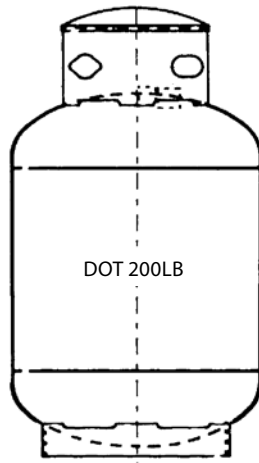

SPECIFICATION	DESCRIPTION
Water Capacity, LBS	476
Overall Length	42.12
Cylinder Diameter	24
Guard Diameter	14
Foot Ring Diameter	20
Tare Weight, Lbs.	147

SPECIFICATION	DESCRIPTION
Water Capacity, LBS	1000
Overall Length	53.25
Cylinder Diameter	30
Guard Diameter	16
Foot Ring Diameter	23.12
Tare Weight, Lbs.	270

PART NUMBER	COLOR
14205.29	Gray
14205.30	White
Upon Request	Special Color

PART NUMBER	COLOR
1499.101	Gray
1499.102	White
Upon Request	Special Color

BASIC COMPARISON	DIAMETER	OL	WT	RETEST PERIOD	MATERIAL THICKNESS	NAMEPLATE	FINISH	TL	TRANSPORTATION WITH PROPANE	RELIEF VALVE PRESSURE
D.O.T. 420	30"	53.25"	270 lbs.	12/5 Yrs.		Stamped in Collar	Powder Coated Mastic Dip	99	Yes- 80%	375
A.S.M.E. 420	30"	53.25"	309	None	13% Heavier More Corrosion Protection	Stainless Steel Riveted in Collar	Powder Coated Mastic Dip	99	Yes- 80%	250

**All cylinders on this page are manufactured to meet or exceed DOT Specification 4BW240.**



**Manchester ASME Tanks**



- Large 16" Dia. Collar
- Large Vented Collar and Foot Ring
  - Full Load Lift-Lugs
- Armor-Clad III Powder Coat Paint
- All Threads Sealed with Blue Everseal
- Heavy-Duty Hinged Lid
- Stainless Steel Nameplate
- Optional Liquid Withdrawal
- Plastic Lids
- Colors Available
- Vacuum Pre-purged

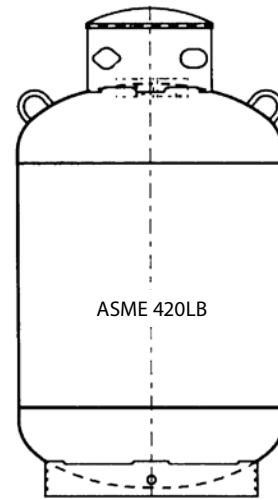
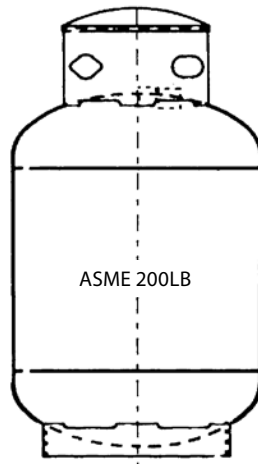

SPECIFICATION	DESCRIPTION
Water Capacity, GAL	57
Overall Length	42.4
Cylinder Diameter	24
Guard Diameter	14
Foot Ring Diameter	18
Tare Weight, Lbs.	172

SPECIFICATION	DESCRIPTION
Water Capacity, GAL	120
Overall Length	53.3
Cylinder Diameter	30
Guard Diameter	16
Foot Ring Diameter	24
Tare Weight, Lbs.	326

PART NUMBER	COLOR
6765.4	Gray
6765.5	White
Upon Request	Special Color

PART NUMBER	COLOR
6762.7	Gray
6762.8	White
Upon Request	Special Color

**100 lb. ASME Manchester Mini**

**100lb ASME Manchester Mini**

**The Perfect Patio Solution**

- Low center of gravity means more stability
- Wide 360° welded collar for safety and ease of installation
- Multivalve and gauge for onsite fill
- Vacuum purged
- HDPE lids

SPECIFICATION	
Overall Length	36.69"
Height	29.75"
Diameter	18"
WC	238 lb.
B	15.5"

TANK ACCESS	
PART NUMBER	DESCRIPTION
A79959	Black HDPE* Lid
A79959.2	White HDPE* Lid
A79958	Hinge
A59887	Clevis Pin
A59888	Cotter Pin

Available in a variety of colors  
\*High Density Polyetholene



Part Number: 68143

*All cylinders on this page are manufactured to meet or exceed the American Society of Mechanical Engineers (ASME) specifications.*

## Motor Fuel Style

**Floor Mount Tank for Narrow Body Pickup Beds and Utility Boxes**



**Motorfuel Tanks for Under Pickup Tool Boxes**

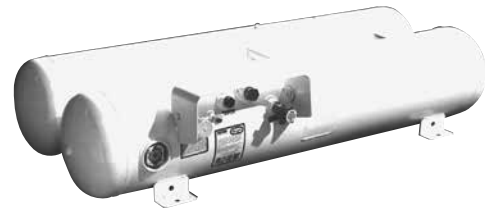

**Standard Type #1-45° Motorfuel Tank for Trucks**



**Underbody, Manifold Motorfuel Tank for Vans (rear mount)**



**Trunk Mount Compact & Mid-Sized Fleet Vehicles**

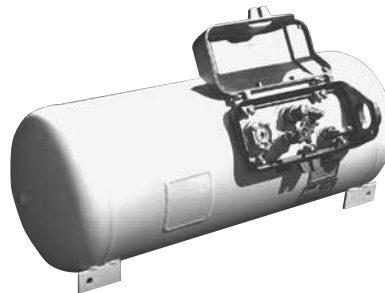

### Repair Parts for 200 Pound Cylinders

CYLINDER TYPE	DESCRIPTION	PART NUMBER
DOT	Multivalve 3/4" for Vapor Withdrawal	8555RT10.6
DOT	Multivalve 3/4" for Vapor Withdrawal	8555RT11.6
DOT/ASME	Service Valve 3/4"	9101RT11.1
ASME	Relief Valve 1", 250 PSI	8544G
DOT	Relief Valve 1", 375 PSI	8544KT
DOT/ASME	Fill Valve 3/4"	7647SCT
DOT/ASME	Float Gauge 1" MNPT	HA180A
DOT/ASME	JR Gauge 24" Dial	JA176B

### Repair Parts for 420 Pound Cylinders

CYLINDER TYPE	DESCRIPTION	PART NUMBER
DOT	Multivalve 3/4"	6533R11.7
ASME	Multivalve 3/4"	6532RT12.0
DOT	Multivalve 1"	6543RT11.7 or 12.0
ASME	Multivalve 1"	8544G
DOT/ASME	Service Valve	9101RT11.1 or 11.7
DOT/ASME	Fill Valve 3/4"	7647SCT
DOT/ASME	Fill Valve 1 1/4"	7579
DOT/ASME	Float Gauge 1" MNPT	HA254J
DOT/ASME	JR Gauge	JA250J

## ASME AutoGas Tanks

### Stock ASME Autogas Tanks

PART #	DIMENSION	WGT	WATER CAPACITY	L.P. CAPACITY	DESCRIPTION	SKID QTY
215547.1	10&10x48	131	30.2	24.2	U45, Remote Fill, Bed Mount Brackets, Under Tool Box	6
23167.1R	12&12x48	148	43.4	34.0	U45, Remote Fill, Bed Mount Brackets, Under Tool Box	6
236147	13&13X32	136	33.0	26.2	L45, Remote Fill, Underbody with Brackets	10
211447	12x48 & 12x60	183	49.1	39.3	U45, Direct Fill, Bed Mount Brackets, Under Tool Box	5
2380417	16x34	91	26.2	21.0	U45, Remote Fill, Vapor Seal Box, Trunk Mount Brackets	8
20067	16X52	152	41.4	33.1	U45, Direct Fill, Bed Mount Brackets, Under Cap or Cover	6
270281	20X48	200	58.4	48.0	U45, Remote Fill, Bed Mount Brackets	4
26087	20x60	231	74.2	59.4	U45, Direct Fill, Bed Mount Brackets	4
23657.1R	24x62	370	109.3	87.5	U45, Direct Fill, Bed Mount Brackets	4

\*NOTE: Contact Customer Service for quote on qualities greater than two skids

### Autogas Accessories

PART #	DESCRIPTION
V13414	Valve 80% Stop Fill Direct
V13415	Valve 80% Stop Fill Remote
G12845	Remote Sender 90 OHM
V13399	Remote Outage Valve

### Non-Stock ASME Autogas Tanks

PART #	DIMENSION	WGT	L.P. CAPACITY (GALLONS)	DIRECT OR REMOTE FIL	DESCRIPTION
2148471	10&10X44	149	22.1	R	U45, Trunk Mount Brackets
270155	10&12X30	115	17.9	R	L45, Underbody with Brackets
270161	11&11x40	130	24.1	R	U45, Trunk Mount Brackets
22987	12x50	70	18.1	D	L45, Underbody with Brackets
230947	13&10X30	104	19.7	R	L45, Underbody with Brackets
270162	13&10X30	135	19.7	R	L45, Underbody with Brackets
256271	14x37	90	17.8	R	U45, Trunk Mount Brackets
23467	16x42	106	26.3	D	U45, Underbody Slick
21077	18X32	105	24.6	D	U45, Underbody Slick
23087	18X36	116	28.1	D	U45, Underbody Slick
23097	18X42	131	33.2	D	U45, Underbody Slick
20727	18x80	221	65.4	D	U45, SCHOOL BUS Slick
23117	20x42	158	40.5	D	U45, Underbody Slick
24457	20x48	176	46.7	D	U45, Bed Mount Brackets, Under Cap or Cover
23127	20x48	177	46.7	D	U45, Underbody Slick
23567	20x60	217	59.4	D	U45, Underbody Slick
200247	20x60	225	59.4	D	U45 W/BRKTS 312 PSI
23257	24x36	205	48.3	D	U45, Underbody Slick
23147	24x48	263	66.2	D	U45, Underbody Slick
220847	12x10&30	114	17.8	R	L45, Underbody with Brackets
211447.1	12x48 with remote	183	39.3	R	U45, Bed Mount Brackets, Under Tool Box
235547	13&13X27	119	21.8	R	L45, Underbody with Brackets
20087	16x62	146	39.8	D	U45, Bed Mount Brackets
20597	24X62	322	87.4	D	U45, Bed Mount Brackets

\*NOTE: Contact Customer Service for quote on qualities greater than 20 pcs.

### Autogas Strap Brackets

PART#	WGT	DESCRIPTION
23964.1	24	10" Standard Strap Brackets
23504.1	25	12" Standard Strap Brackets
2636.1	28	14" Heavy Duty Strap Brackets
2518.1	39	16" Standard Strap Brackets
2506.1	38	18" Standard Strap Brackets
25291.1	62	18" Heavy Duty Strap Brackets
2507.1	40	20" Standard Strap Brackets
25071.1	63	20" Heavy Duty Strap Brackets
2509.1	46	24" Standard Strap Brackets
25091.1	64	24" Heavy Duty Strap Brackets

*All tanks on this page are manufactured to meet or exceed the American Society of Mechanical Engineers (ASME) specifications.*

**Order by phone: 800-922-0724**

## Accessories for Motorfuel Tanks

### Heavy Duty Strap Brackets

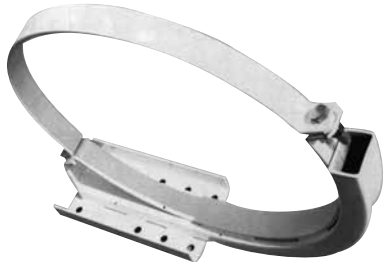

PART NUMBER	SIZE	BRACKETS DESCRIPTION	WEIGHT
2636*	14"	Pair, Standard Duty	36
2518	16"	Pair, Standard Duty	37
2506	18"	Pair, Standard Duty	41
25291	18"	Pair, Heavy Duty for School Bus, etc	82
2507	20"	Pair, Standard Duty	42
25071	20"	Pair, Heavy Duty	84
25091	24"	Pair, Heavy Duty	101

\* Special order.



### RegO Double Check Filler Valve

Designed to provide fast filling of forklift, motor fuel, and recreational vehicle tanks.



PART NUMBER	STYLE	ACME HOSE CONNECTION	TANK CONNECTION
7647SCT	w/ Lanyard & Cap	1 3/4"	3/4" M. NPT

Replacement Fill Cap Only – Part Number: MSCP-M3274-9P  
Replacement Fill Cap with Lanyard – Part Number 3174-93L

### Auto-stop Filler Valve



V13414

PART NUMBER	DESCRIPTION
V13414	CEODEUX 80% Stop-Fill Valve 3/4" MPT

\* Requires a 3/4" fill valve.

### RegO Relief Valves – Fully Internal “Pop Action”

8543 Series relief valves are designed for use as a primary relief valve in larger ASME motor fuel containers such as on buses, trucks and construction equipment.

8544 Series relief valves are designed for use as a primary relief valve in smaller ASME and DOT motor fuel containers such as on tractors, lift trucks, cars and taxicabs.

PART NUMBER	CONTAINER TYPE	START TO DISCHARGE SETTING PSIG	CONTAINER CONNECTION M. NPT	OVERALL HEIGHT (APPROX.)	HEIGHT ABOVE COUPLING (APPROX.)	HEX WRENCHING SECTION	PIPE AWAY ADAPTER	CAP
8544T	ASME	312	1"	5 7/16"	7/8"	1 5/16"	7544-11A*	7544-41
8543T	ASME	312	1 1/4"	5 7/16"	7/8"	1 11/16"	7543-10**	7543-40C

\* 1" MNPT Outlet Connection

\*\* 1 1/4 MNPT Outlet Connection



**Manchester RV ASME Vapor Service Tanks**

PART #	WEIGHT	SIZE	W.C.	LP CAP	DESCRIPTION
6808	31	6X30	3.3	2.64	SF Vapor Appliance & 2 Top Brkts
6811	45	8X42	8.4	6.72	L45 Vapor Appliance & Channel Brkts
6813	40	10X23	6.9	5.52	L45 Vapor Appliance & Channel Brkts
6812	36	10X23	6.9	5.52	SF Vapor Appliance & Channel Brkts
6814	54	10X32	9.9	7.92	L45 Vapor Appliance & Channel Brkts
6815	44	10X32	9.9	7.92	SF Vapor Appliance & Channel Brkts
6856	52	10X32	9.9	7.92	SF Vapor Appliance & Channel Brkts
68045	52	10X32	9.9	7.92	SF Vapor Appliance & Channel Brkts
6801	45	12X24	10.3	8.24	SF Vapor Appliance & Channel Brkts
6840	50	12X28	12.2	9.76	SF Vapor Appliance & Channel Brkts
6817	59	12X32	14.1	11.3	L45 Vapor Appliance & Channel Brkts
6802	60	12X32	14.1	11.3	SF Vapor Appliance & Channel Brkts
6803	65	12X32	14.1	11.3	SF Vapor Appliance & Rear Corner Brkts
6758	90	12X40	17.9	14.3	SF Vapor Appliance & Top Blade Brkts
6820	73	12X42	18.9	15.1	L45Vapor Appliance & 6 Corner Brkts
6819	82	12X42	18.9	15.1	SF Vapor Appliance & Top Angle Brkts
6898	53	12X42	18.9	15.1	SF Vapor Appliance Remote & Top Brkts
68028	75	12X42	18.9	15.1	SF Vapor Appliance & Top Angle Brkts
6822	60	13X26	13.2	10.6	SF Vapor Appliance & Top Angle Brkts
6823	71	13X34	17.6	14.1	SF Vapor Appliance & Top Angle Brkts
6824	54	14X21	11.9	9.52	SF Vapor Appliance & Top Angle Brkts
6761	70	14X30	17.7	14.2	SF Vapor Appliance & Top Angle Brkts
6760	77	14X32	19	15.2	SF Vapor Appliance & Top Angle Brkts
6826	69	14X34	20.3	16.2	SF Vapor Appliance & Top Angle Brkts
6887	69	14X34	20.3	16.2	SF Vapor Appliance Remote & Top Angle Brkts
28026	81	14X40	24.2	19.4	SF Dual Service & 6 Corner Brkts
6828	81	14X40	24.2	19.4	SF Vapor Appliance & 6 Corner Brkts
6829	83	14X40	24.2	19.4	SF Vapor Appliance & Top Angle Brkts
6829.2	83	14X40	24.2	19.4	SF Vapor Appliance Remote Solenoid & Top Angle Brkts
6804	89	14X40	24.2	19.4	SF Vapor Appliance & Top Corner Brkts
6807	84	14X40	24.2	19.4	SF Vapor Appliance & Wing Brkts
68119	84	14X40	24.2	19.4	SF Vapor Appliance & Bottom Blade Brkts
6879	89	14X40	24.2	19.4	SF Vapor Appliance & Top Angle Brkts
68037	103	14X47	28.7	23	SF Vapor Appliance & Rear Blade Brkts
68072	109	14X47	28.7	23	SF Vapor ApplianceE & Back Angle Brkts
6830	90	14X48	29.3	23.4	SF Vapor Appliance & Top Angle Brkts
68120	98	14X48	29.3	23.4	SF Vapor Appliance Remote Solenoid & BTM Teardrop Brkts



## Manchester RV ASME Vapor Service Tanks (cont.)

PART #	WEIGHT	SIZE	W.C.	LP CAP	DESCRIPTION
28001	104	14X48	29.3	23.4	SF Vapor Appliance & Top Angle Brkts
68140	140	14X85	53.1	42.48	EF Vapor Appliance & Bottom Angle Brkts, Remote Sender
6839	82	16X27	20.3	16.2	SF Vapor Appliance & Top Angle Brkts
6842	93	16X32	24.5	19.6	SF Vapor Appliance & Top Angle Brkts
6874.2	91	16X32	24.5	24.5	SF Vapor Appliance & Rear Blade Brkts, Remote Sender
28016	101	16X33	25.4	20.3	SF Liquid Generator & Top Corner Brkts
6809	106	16X33	25.4	20.3	SF Vapor Appliance & Rear Angle Brkts
6847.1	118	16X40	31.3	25	SF Dual SRV Remote, Solenoid & Top Teardrop Brkts
6841	116	16X40	31.3	25	SF Vapor Appliance & Top Angle Brkts
6833	116	16X40	31.3	25	SF Vapor Appliance & Rear Angle Brkts
6867	116	16X40	31.3	25	SF Vapor Appliance Stop Fill & Top Angle Brkts
6845	120	16X42	32.9	26.3	SF Vapor Appliance & Top Angle Brkts
68000	137	16X48	38	30.4	SF Dual SRV Remote, Liq/VAP Solenoid & BTM Teardrop Brkts
68000.2	137	16X48	38	30.4	SF Dual SRV Remote, Solenoid & BTM Teardrop Brkts
68036	130	16X48	38	30.4	SF Vapor ApplianceE & Back Angle Brkts
6866	136	16X48	38	30.4	SF Vapor Appliance & Top Teardrop Brkts
6878	134	16X48	38	30.4	SF Vapor Appliance & Top Angle Brkts
6878.1	134	16X48	38	30.4	SF Vapor Appliance Remote & Top Angle Brkts
68053	137	16X48	38	30.4	SF Vapor Service & Bottom Teardrop Brkts
68052	137	16X48	38	30.4	SF Vapor Service Remote & Top Teardrop Brkts
6853.1	137	16X48	38	30.4	Dual Service Remote, Solenoid & Top Teardrop Brkts
6853.2	137	16X48	38	30.4	Dual SRV Remote, Liq/VAP Solenoid & Top Teardrop Brkts
68154	138	16X50	39.7	31.8	EF Vapor Appliance & Bottom Teardrop Brkts
68007	118	18X36	34.9	27.9	SF Vapor Appliance & Top teardrop Brkts
68026	125	18X36	35.7	28.56	SF Vapor Appliance & Rear Angle Brkts
6837	149	18X48	47.7	38.2	SF Vapor Appliance & Top Angle Brkts
6875	134	20X33	38.7	31	SF Vapor Appliance & Bottom Teardrop Brkts
68124	143	20X36	42.7	34.2	SF Vapor Appliance & Bottom Blade Brkts
28011	176	20X42	50.6	40.5	SF Liquid Gen/Vapor Appliance & Teardrop Brkts
6849.1	156	20X42	50.6	40.5	SF Vapor Appliance & Top Angle Brkts
6880	215	20X56	69	55.2	SF Dual Vapor Appliance & Top Teardrop Brkts

SF = Side Fit (valves are 90 degrees on the horizontal line on the side of the tank)  
 EF = End Fit (valves are in the head)  
 L45 = Lower 45 (valves are in the lower 45 position below the horizontal line)

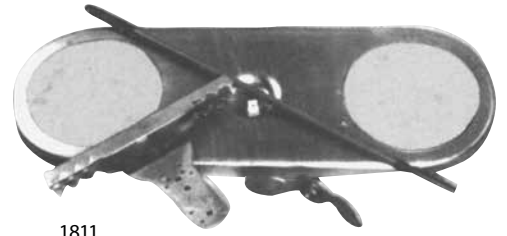

1811

### Cylinders Mounting Brackets for RVs

PART NUMBER	DESCRIPTION
1803	30 LB Dual Rack Complete
1811	40 LB Dual Rack Complete
1805	20 LB Center Rod 3/8" X 18"
1806	30 LB Center Rod 3/8" X 24"
1807	40 LB Center Rod 3/8" X 30"
1809	Wing Nut Only 3/8"
1810	Dual Rack Base with 3/8" Nut
1588	Hold Down Bar
1589	Regulator Mounting Bracket

## RV Tank Accessories and Replacement Parts



### Regulators – Twin Stage

The first stage features a lever arm design that improves both the efficiency and regulation. Combined with the second stage regulator, the overall performance assures even smoother and more continuous flow of gas to all appliances. 160,000 BTU capacity.

PART NUMBER	DESCRIPTION
290-GR9950	Vent Over Outlet
299-GR9959	9 O'clock Vent



### RegO Check Filler Valve

Designed to provide fast filling of forklift, motor fuel, and recreational vehicle tanks.



PART NUMBER	STYLE	ACME HOSE CONNECTION	TANK CONNECTION M. NPT
7647SCT	W/ Lanyard & Cap	1 3/4"	3/4" M.NPT
299-00	9 O'clock Vent	-	-

Replacement Fill Cap Only – Part Number: MSCP-M3274-9P  
Replacement Fill Cap with Lanyard – Part Number 3174-93L



G12653

PART NUMBER	DESCRIPTION
G12653	Dial, gauge ASME

### RegO Relief Valves – Fully Internal "Pop Action"

8543 Series relief valves are designed for use as a primary relief valve in larger ASME motor fuel containers such as on buses, trucks and construction equipment.

8544 Series relief valves are designed for use as a primary relief valve in smaller ASME and DOT motor fuel containers such as on tractors, lift trucks, cars and taxicabs.

PART NUMBER	CONTAINER TYPE	START TO DISCHARGE SETTING PSIG	CONTAINER CONNECTION M. NPT	OVERALL HEIGHT (APPROX.)	HEIGHT ABOVE COUPLING (APPROX.)	HEX WRENCHING SECTION
8544T	ASME	312	1"	5 7/16"	7/8"	1 5/16"
8543T	ASME	312	1 1/4"	5 7/16"	7/8"	1 11/16"



### Extend-A-Stay and Extend-A-Flow

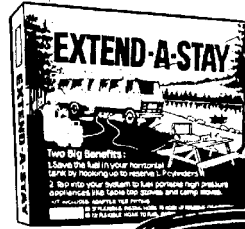

#### Extend-A-Stay

**536-00 Standard Kit** with 5 ft. pigtail and tee fitting

**537-00 Deluxe Kit** with tee fitting, 12 ft. hose and 5 ft. pigtail

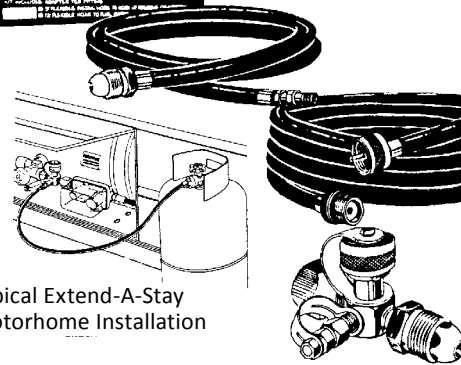

Typical Extend-A-Stay Motorhome Installation



538-00  
Extend-A-Flow Plus  
QCC/TYPE 1

## Underground Anchoring Equipment

### For 500 and 1000 Gallon Tanks

Designed to secure both 500 and 1000 gallon U/G Tanks

PART NUMBER	DESCRIPTION
UG-KIT	(2) 1/2" X 15 FT CABLES (4) 1/2" X 6 TURNBUCKLES (6) 1/2" CABLE CLIPS (4) 1/2" X 9" X 15" ANCHORS



## Minuteman Tank Anchoring System for Flood Plain Tiedown

High waters can dislodge unanchored tanks causing spills, environmental and property damage.

- Loose tanks may explode causing injuries.
- Buried tanks can be pushed to the surface by the buoyant effect of soil saturated by water.
- Floating tanks become battering rams causing property damage.

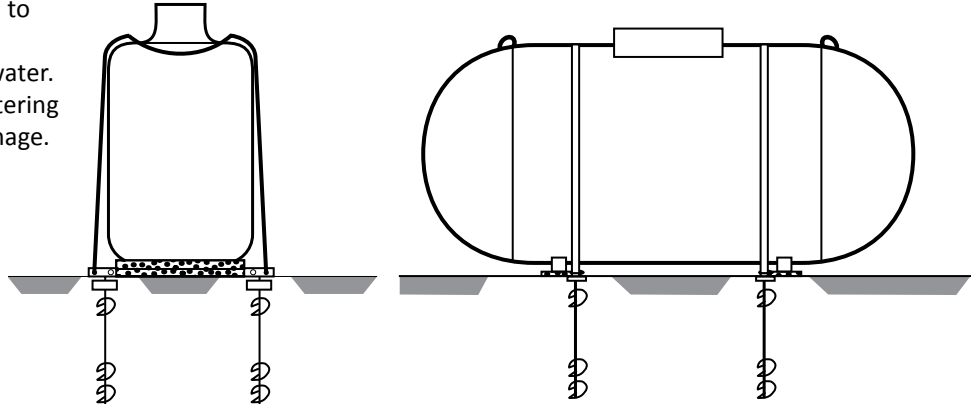

PART NUMBER	DESCRIPTION	USE
1346	36" Earth Anchor w/ 4" & 6" Disks	Dense / Normal Soil
1593	36" Earth Anchor w/ 4" & 6" Disks & Stabilizer	Dense / Medium Soil
1284	50" Earth Anchor w/ Double 4" Disks	Loose to Medium Soil
2391	Dry Concrete Anchor w/ Bolt Expansion Sleeve	Concrete - Dry
2010- Minute	Split Bolt and Nut	All Anchors
2365	Stainless Steel Sling w/ Sheathed Strap & Seals	For Vertical Cylinders
2375	Stainless Steel Strap 100ft Roll	Note: 120 gal. to 350 gal. tanks need 1 strap and 2 anchors. 351 gal. tanks to 1500 gal. tanks require 2 straps and 4 anchors.
2382	Strap Sheathing- 200 Feet	
2730	Minute Man Drive Machine	
2741	Minute Man Anchor Adapter	



## Trinity Underground Tanks

### No Mastic Needed!

### Red Oxide Powder Coating Epoxy Designed for Immediate Burial

- Duplicate Data Plates
- Convenient and Easy Anode Attachment, allows for Testing of Cathodic Protection
- Available 14" or 28" Risers
- Vacuum Pre-purged
- Seamless Dome
- Plastic Rust Free Domes

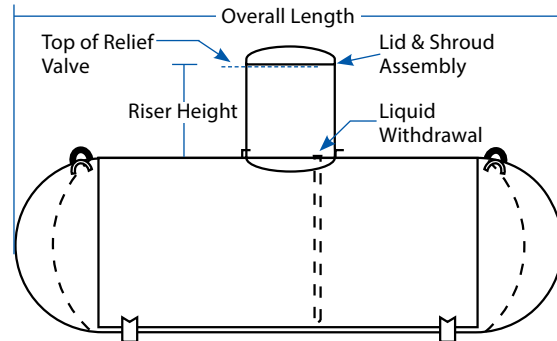

TANK SIZE IN W.G	NUMBER PER		OVERALL LENGTH	OUTSIDE DIAMETER	OVERALL HEIGHT		WEIGHT LBS
	STACK	LOAD			14" RISER	28" RISER	
120 GAL*	9	63	5'5 7/8"	24"	3'9 7/8"	4'8 3/8"	252
250 GAL*	7	35	7'2 1/2"	31.5"	4'5 3/8"	5'3 3/8"	472
320 GAL*	7	28	8'11 3/4"	31.5"	4'5 3/8"	5'3 3/8"	588
500 GAL*	5	25	9'10"	37.42"	4'11 3/8"	5'9 7/8"	921
1000 GAL*	5	15	15' 10 7/8"	40.96"	5'2 7/8"	6'1 3/8"	1731
2000 GAL*	4	8	23'9 3/8"	46.614"	5'8 13/16"	6'7 5/16"	3685

\* Tanks are available with short or long risers

### Replacement Valves for Trinity Underground Tanks

TANK SIZE	MULTIVALVES	REGO CHEK-LOK VALVES	
		BOTTOM 1 1/4"	TOP 3/4"
120 WG	G8475RL	7591UT	7590UT
250 WG	G8475RL	7591UT	7590UT
320 WG	G8475RL	7591UT	7590UT
500 WG	G8475RL	7591UT	7590UT
1000 WG	G8475RL	7591UT	7590UT
2000 WG	G8475RL	7591UT	7590UT

### Replacement Float Gauges for Trinity Underground Tanks

TANK SIZE	TAYLOR FLOAT GAUGES		ROCHESTER FLOAT GAUGES		REPLACEMENT DIAL	
	14" RISER	28" RISER	14" RISER	28" RISER	TAYLOR	ROCHESTER
120 WG	JB213B	JB340A	6281-0490	6281-0491	2700CV	5-01813
250 WG	JB251A	JB376A	6281-0534	6281-0535	2700CV	5-01813
320 WG	JB251A	JB376A	6281-0534	6281-0535	2700CV	5-01813
500 WG	JB277A	JB404D	6281-0427	6281-0426	2700CV	5-01813
1000 WG	JB297A	JB424C	6281-0524	6281-0418	2700CV	5-01813
2000 WG	-	JB450D	-	6281-0534	2700CV	-

*All tanks on this page are manufactured to meet or exceed the American Society of Mechanical Engineers (ASME) specifications.*

## Trinity Aboveground and Above/Underground Tanks

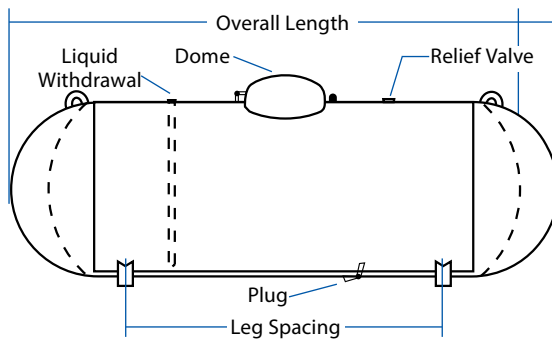

- Powder Coated for Long Lasting Protection
- Vacuum Pre-purged
- AG/UG with Red Oxide Underground Protection
- Available in a Wide Range of Colors
- AG/UG Plastic Rust Free Domes

### Trinity Aboveground and Above/Underground Tanks

TANK SIZE IN W.G	NUMBER PER		OVERALL LENGTH	OUTSIDE DIAMETER	OVERALL HEIGHT	LEG WIDTH	LEG SPACING	WEIGHT LBS
	STACK	LOAD						
120 GAL*	12	96	5'5 7/8"	24"	3'9 7/8"	10 1/8"	3'	245
250 GAL*	9	63	7'2 1/2"	31.5"	4'5 3/8"	12 3/4"	3'6"	472
320 GAL*	9	45	8'11 3/4"	31.5"	4'5 3/8"	12 3/4"	4' 1/4"	588
500 GAL*	6	30	9'10"	37.42"	4'11 3/8"	15"	5'	871
1000 GAL*	5	15	15' 10 7/8"	40.96"	5'2 7/8"	16 1/4"	9'	1729
2000 GAL*	4	8	23'9 3/8"	46.614"	5'8 13/16"	21"	20'	3676

### Replacement Parts for Trinity Aboveground and Above/Underground Tanks

TANK SIZE	MULTIVALVES	REGO CHEK-LOK VALVES		RELIEF VALVE	FILLER VALVE
		BOTTOM 1 1/4"	TOP 3/4"		
120 WG	7556RT DT 6.7	7591UT	7590UT	7583G	7579T
250 WG	7556RT DT 8.5	7591UT	7590UT	7583G	7579T
320 WG	7556RT DT 8.5	7591UT	7590UT	7583G	7579T
500 WG	7556RT DT 10.5	7591UT	7590UT	8684G	7579T
1000 WG	7556RT DT 11.3	7591UT	7590UT	8685G	7579T
2000 WG	7556RT DT 12.7	7591UT	7590UT	8685G	7579T

### Replacement Parts for Trinity Aboveground and Above/Underground Tanks

TANK SIZE	TAYLOR GAUGES 1" MNPT	ROCHESTER GAUGES 1" SCREW	REPLACEMENT DIAL	
			TAYLOR	ROCHESTER
120 WG	HA130A	B8981-1224	2701CV	5-01749
250 WG	HA162A	B8981-1232	2701CV	5-01749
320 WG	HA162A	B8981-1232	2701CV	5-01749
500 WG	HA194A	B8981-1237	2701CV	5-01749
1000 WG	HA210A	B8981-1241	2701CV	5-01749
2000 WG	-	B8981-1146	2701CV	-

*All tanks on this page are manufactured to meet or exceed the American Society of Mechanical Engineers (ASME) specifications.*

**American Welding & Tank Replacement Parts**
**Underground Tank Replacement Parts**

TANK SIZE	MULTIVALVE	DIP TUBE LENGTH	FILLER VALVE	RELIEF VALVE	FLOAT JR SCREW		REPLACE DIAL	LIQUID CHECK VALVE	
					1 1/4"	1"		1-1 1/4" BOT	3/4" TOP
120 GAL	7556RT12.0	7	7579	7583G	TA130A	HA130A	5-01749	N/A	7590U
150 GAL	7556RT12.0	7	7579	7583G	TA130A	HA130A	5-01749	N/A	7590U
250 GAL	7556RT12.0	9	7579	7583G	TA160A	HA160A	5-01749	Optional	7590U
325 GAL	7556RT12.0	9	7579	7583G	TA160A	HA160A	5-01749	Optional	7590U
500 GAL	7556RT12.0	10	7579	8684G	TA194A	HA194A	5-01749	Plugged	7590U
850 GAL	7556RT12.0	11.1	7579	8685G	-	HA210A	5-01749	Plugged	7590U
1000 GAL	7556RT12.0	11	7579	8685G	TA210A	HA210A	5-01749	Plugged	7590U
1450 GAL	7556RT13.0	13	7579	8685G	TA240A	-	5-01749	Plugged	7590U
1990 GAL	7556RT13.0	13	7579	8685G	TA240A	-	5-01749	Plugged	7590U

**Underground Tank Replacement Parts**

TANK SIZE	MULTIVALVE	JR FLOAT GAUGE		REPLACE DIAL
		11 1/4"	18 1/4"	
120 GAL	G8475RL	JB232A	JB302A	5-01813
150 GAL	G8475RL	JB232A	JB302A	5-01813
250 GAL	G8475RL	JB262A	JB332A	5-01813
325 GAL	G8475RL	JB262A	JB332A	5-01813
500 GAL	G8475RI	JB296A	JB370F	5-01813
850 GAL	G8475RI	-	-	5-01813
1000 GAL	G8475RL	JB316C	JB386D	5-01813
1450 GAL	G8475RI	-	-	5-01813
1990 GAL	G8475RI	-	-	5-01813

**Replacement Parts for G8475RV**

PART NUMBER	DESCRIPTION
MV3231G	Relief Valve
19104-80	Service Valve Repair Bonnet
8475-50	Filler Valve Repair
8475-51A	Vapor Equalizing Kit

## Magnesium Anode Bag



5, 9, and 17lb anode with 10ft X #12 gauge electrical lead attached. Bagged and boxed for shipping protection.

Part Numbers:  
MG-5LB  
MG-9LB  
MG-17LB

## Purge-It-Vac Adapter

- No labor
- No wasted propane

The purge-it-vac allows you to insert methanol and your first fill of propane without disconnecting the adapter. The purge-it vac adapter is easy to use and meets NPGA #133-899a) on the purging of LP-Gas containers.

Part Number: Purge-It-Vac



## Anode Monitoring Station

When buried in the ground, provides a central point where 4 or 5 underground tank anodes can be monitored.

- ABS plastic shaft
- PVC terminal board
- Heavy-duty cast iron cover and collar



Part Number: NM-4 4 Terminal  
Part Number: NM-5 5 Terminal

## Electrode Extension



30" long intermediate electrode extension.

Can be used with

MCM model ETM, I.A. and LC series meters or between the electrode and the standard electrode extension so that the electrode can be easily placed at the desired location inside manholes, water tanks, etc. Will fit through a 1" diameter augered hole.

Electrode Part Number: 16203 Cane Adapter Part Number: 16285

## Anode Test Kit

Anode Test Kit includes:

- 6A half cell - reference electrode
- Digital multimeter w/wired probes
- Storage case

Part Number: ATK-1



## Anode Splice

Utilized in conjunction with pre-mounted anode lead wires on Underground Tanks.



BSK-1

Includes burndy crimp and heat-shrink sleeve. Basic pliers or electrical crimp tool provide a solid connection.

## Riser Pipe Clamp



Retrofit anode connection for existing or new underground tanks.

Part Number: RPC.1

PART NUMBER	DESCRIPTION
6A	6A Half Cell Reference Electrode
16906	Copper Sulfate (12 oz.)
17105	Copper Sulfate Anti-Freeze
16281	Telescoping extension pole
16285	Bracket mounting adapter for telescoping extension pole
T&R50300	Copper Sulfate Crystals (1 lb. 3 oz.)
T&R50060	Flat tip assembly for 6A
T&R50070	Pointed tip assembly for 6B
T&R50300	Copper sulfate crystals
T&R50404	Shunt .001 OHM orange



**V-101-113** 10" x 14"  
Aluminum • Printed red and black



**V-127** Red on White Vinyl 30" x 12" with required 2" letters for Emergency Remote Shutdown Station  
**P-127** Red on White Plastic 30" x 12" with required 2" letters for Emergency Remote Shutdown Station



**V-81** 10" x 12"  
Pull to close  
Printed red



**V-82** 10" x 12"  
Push to close  
Printed red



**V-47** 9" x 38" • Printed red



**V-26A** 12" x 18" • **M-26A** 24" x 36"  
Printed red

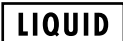

**V-90** 1" x 4" • Printed red



**V-91** 1" x 4" • Printed red



**V90-5** Series of 5 labels  
Each 1" x 4" • Printed red



**V91-5**



**V-28A** 6 3/4" x 27 1/4"  
**V-28B** 5" x 18"  
**V-28BB** 4" x 14"  
**V-28C** 3" x 12"  
**M-28A** 6 3/4" x 27 1/4"  
Printed red



**V-49** 10" x 42" • Printed red



**V-202** 9" x 27" • Printed orange



**V-26B** 12" x 18" • **M-26B** 12" x 18"  
**M-26C** 24" x 36" • Printed red

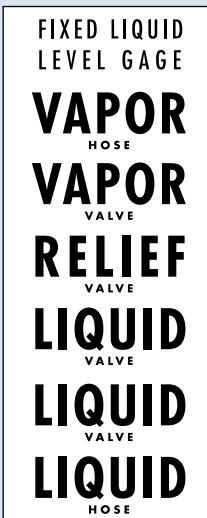

**V-8** Series of 7 labels  
Each 1" x 3"  
Printed red

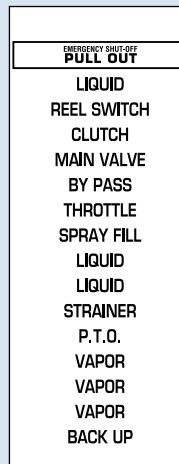

**V-92** Series of 16 labels  
Each 3/8" x 1 3/4"  
Printed red



**V-23A** 6 3/4" x 27 1/2" **V23C** 3" x 14"  
**V-23B** 4 3/4" x 27 1/4" **M-23B** 4 3/4" x 27 1/4"  
**V-23BB** 4" x 22" **M-23BB** 4" x 22"  
Printed red



**PROPANETAG** 100 per roll 1" x 6"  
Black letters on a yellow background

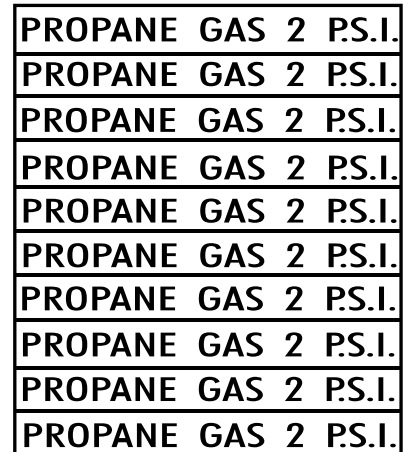

**V-62** 4" x 5 1/2" sheet of 10 labels  
Each 3/8" x 3" • Black on yellow vinyl

**Bobtail Piping and Control Decal**

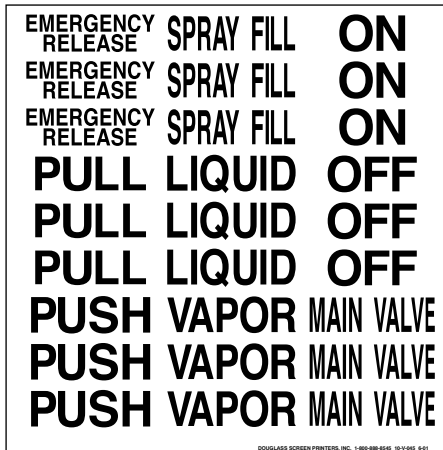

**V-45** 10" x 10" label sheet  
Series of 27 labels  
Each 1" x 3" • Printed red

Custom Signs Available. Call for a Quote.

Use the following legend for all signs and decals:

M	Metal (Aluminum)	A	6" Letters
S	Scotchlite Brand Reflective	B	4" Letters

V	Vinyl (Self-adhesive)	BB	3" Letters
P	Plastic	C	2" Letters
G	Magnetic	D	1" Letters

## V-56R

3 3/8" x 10"

3-In-1 label for commercial portable cylinders, 100 pack

**DA** **FLAMMABLE GAS UNDER PRESSURE • LEAKING LP-GAS CAN CAUSE A FIRE OR EXPLOSION IF IGNITED • CONTACT LP-GAS SUPPLIERS FOR REPAIRS OR DISPOSAL OF THIS CYLINDER OR UNUSED LP-GAS • FOR OUTDOOR USE ONLY • DO NOT USE OR STORE CYLINDER IN A BUILDING, GARAGE OR ENCLOSED AREA.**

### Customer Warning:

- Know the odor of LP-gas. Under certain circumstances, you may not be able to smell the odorant. If you hear or smell leaking LP-gas, immediately get everyone away from the cylinder and call the fire department.
- Caution your LP-gas supplier to:
  - purge the cylinder of trapped air prior to first filling
  - check the cylinder requalification date
  - be certain not to overfill the cylinder
- LP-gas is heavier than air and can settle in low places while dissipating.
- Contact with the liquid contents of the cylinder will cause freeze burns to the skin.
- Do not allow children to tamper or play with the cylinder.
- When the cylinder is not connected for use, keep the valve turned off. If your cylinder valve looks like the POL TYPE (Figure 3) and is of 45 lb. LP-Gas capacity or less, the outlet must also be plugged.
- Do not use, store or transport cylinder where it could be exposed to high temperatures. Relief valve can open allowing a large amount of flammable gas to escape.
- When transporting, keep cylinder secured in an upright position with cylinder valve turned off. If the cylinder is of 45 lb. LP-Gas capacity or less and looks like the POL TYPE (Figure 3), the outlet must also be plugged.
- Self-contained outdoor cooking appliances must be limited to one cylinder of 20 lbs. LP-Gas capacity or less.

### When Connecting for Use:

- Use only in compliance with applicable codes.
- Read and follow appliance manufacturer's instructions. If regulator has an internal threaded coupling nut and the cylinder valve has large outside threads, tighten the coupling nut by turning clockwise (TYPE 1-Figure 1).
- If regulator has a plug-in connection, pull valve sleeve back, insert male plug fully and release valve sleeve (TYPE 2-Figure 2). If the regulator has an external threaded coupling nut, it has left-hand threads and must be tightened by turning counter clockwise (POL TYPE-Figure 3).
- Turn off all valves on appliance.
- Do not check for gas leaks with a match or open flame.
- Apply soapy water at areas marked "X" after opening cylinder valve. If bubbles appear, close valve and have an LP-gas service person make needed repairs. Also check appliance valves and connections for leakage before lighting appliance.
- Light appliance(s) following manufacturer's instructions.
- When appliance(s) is not in use, keep cylinder valve closed.

DO NOT REMOVE, DEFACE OR OBLITERATE THIS LABEL  
EXCEPT AS AUTHORIZED BY NFPA 58 OR B149.2 (in Canada)

DSP-08-V-56R 1-800-888-8545

**LIQUEFIED PETROLEUM GAS UN 1075 PROPANE**

THIS LP TANK IS EQUIPPED WITH A SAFETY RELIEF VALVE. DO NOT PLACE INSIDE ANY ENCLOSED OR HEATED AREA.

**FLAMMABLE GAS 2**

NFPA HAZARD RATING: HEALTH HAZARD 4, FIRE HAZARD 0, REACTIVITY 0, SPECIAL HAZARD 0.

PERSONAL PROTECTION: Goggles, Gloves.

## SP-53R

4" x 9"

Portable cylinder warning label "Duty to Warn"  
Yellow vinyl printed black  
See page 91 for new warning label

**DA** **FLAMMABLE GAS UNDER PRESSURE • LEAKING LP-GAS CAN CAUSE A FIRE OR EXPLOSION IF IGNITED • CONTACT LP-GAS SUPPLIERS FOR REPAIRS OR DISPOSAL OF THIS CYLINDER OR UNUSED LP-GAS • FOR OUTDOOR USE ONLY • DO NOT USE OR STORE CYLINDER IN A BUILDING, GARAGE OR ENCLOSED AREA.**

### Customer Warning:

- Know the odor of LP-gas. Under certain circumstances, you may not be able to smell the odorant. If you hear or smell leaking LP-gas, immediately get everyone away from the cylinder and call the fire department.
- Caution your LP-gas supplier to:
  - purge the cylinder of trapped air prior to first filling
  - check the cylinder requalification date
  - be certain not to overfill the cylinder.
- LP-gas is heavier than air and can settle in low places while dissipating.
- Contact with the liquid contents of the cylinder will cause freeze burns to the skin.
- Do not allow children to tamper or play with the cylinder.
- When the cylinder is not connected for use, keep the valve turned off. If your cylinder valve looks like the POL TYPE (Figure 3) and is of 45 lb. LP-Gas capacity or less, the outlet must also be plugged.
- Do not use, store or transport cylinder where it could be exposed to high temperatures. Relief valve can open allowing a large amount of flammable gas to escape.
- When transporting, keep cylinder secured in an upright position with cylinder valve turned off. If the cylinder is of 45 lb. LP-Gas capacity or less and looks like the POL TYPE (Figure 3), the outlet must also be plugged.
- Self-contained outdoor cooking appliances must be limited to one cylinder of 20 lbs. LP-Gas capacity or less.

### When Connecting for Use:

- Use only in compliance with applicable codes.
- Read and follow appliance manufacturer's instructions.
- If regulator has an internal threaded coupling nut and the cylinder valve has large outside threads, tighten the coupling nut by turning clockwise (TYPE 1-Figure 1).
- If regulator has a plug-in connection, pull valve sleeve back, insert male plug fully and release valve sleeve (TYPE 2-Figure 2). If the regulator has an external threaded coupling nut, it has left-hand threads and must be tightened by turning counter clockwise (POL TYPE-Figure 3).
- Turn off all valves on appliance.
- Do not check for gas leaks with a match or open flame.
- Apply soapy water at areas marked "X" after opening cylinder valve. If bubbles appear, close valve and have an LP-gas service person make needed repairs. Also check appliance valves and connections for leakage before lighting appliance.
- Light appliance(s) following manufacturer's instructions.
- When appliance(s) is not in use, keep cylinder valve closed.

DO NOT REMOVE, DEFACE OR OBLITERATE THIS LABEL  
EXCEPT AS AUTHORIZED BY NFPA 58 OR B149.2 (in Canada)

DSP-SP-53R

**TYPE 1 (Figure 1)**  
PRESSURE RELIEF VALVE, HANDWHEEL, PLASTIC COUPLING NUT, LIQUID LEVEL INDICATOR (OPTIONAL), PROPANE CYLINDER, REGULATOR, VENT

**TYPE 2 (Figure 2)**  
PRESSURE RELIEF VALVE, HANDWHEEL, PLASTIC COUPLING NUT, LIQUID LEVEL INDICATOR (OPTIONAL), PROPANE CYLINDER, REGULATOR, VENT

**POL TYPE (Figure 3)**  
PRESSURE RELIEF VALVE, HANDWHEEL, PLASTIC COUPLING NUT, LIQUID LEVEL INDICATOR (OPTIONAL), PROPANE CYLINDER, REGULATOR, VENT

**LIQUEFIED PETROLEUM GAS UN1075**

**FLAMMABLE GAS 2**

M&J GAS CO.  
2014 Hwy 20, Dallas, TX 75241  
(619) 675-0043

## A-16

Minimum order 3,500  
White vinyl printed red and black

**LIQUEFIED PETROLEUM GAS UN1075**

**LIQUEFIED PETROLEUM GAS UN1075**

**FLAMMABLE GAS 2**

## AA-16

3 3/4" x 2"  
Minimum order 100  
Not available curved  
White vinyl printed red and black  
AA-16R 500 per roll  
White vinyl printed red and black

**PROPANE UN 1075**

KEEP OUT OF REACH OF CHILDREN  
Do not use if you smell gas. If you smell gas, do not touch anything. Do not use if you smell gas. Do not use if you smell gas. Do not use if you smell gas.

**FLAMMABLE GAS 2**

AA16

## CS-33ROLL

500 per roll  
White vinyl printed red and black

**LIQUEFIED PETROLEUM GAS UN1075**

**FLAMMABLE GAS 2**

FLAMMABLE GAS NEVER USE OR STORE INDOORS  
GAS INFLAMMABLE NUNCA SE USE O GUARDE ADENTRO

## AA-16-BI

Minimum order 100  
White vinyl printed red and black

# FLAMMABLE GAS

M-17B 6" x 24" • V-17A 8" x 30"  
V-17B 6" x 24" • V-17C 3" x 12"  
Printed red

# FLAMMABLE

V-24A 7" x 28" • V-24B 5" x 22"  
V-24BB 4" x 22" • V-24C 3" x 14"  
V-48 9" x 38" Printed red

**PROPANE**

NFPA HAZARD RATING: HEALTH HAZARD 4, FIRE HAZARD 0, REACTIVITY 0.

—Extremely Flammable Gas  
—Heavier than Air  
—Simple Asphyxiant  
—Oxidized to warn of its presence  
—Contact with Liquid will cause Freezing of Tissue  
—P.L. 1000 PSI  
—Store container outside and keep cool (under 130°F.)  
—Turn off container valve when not in use

PERSONAL PROTECTION: Goggles, Gloves.

CONSULT CORRESPONDING MSDS FOR FURTHER INFORMATION AND INSTRUCTIONS.  
AFFIX TO ALL PORTABLE CONTAINERS USED BY COMMERCIAL CUSTOMERS.

HZ 116

## HZ-116

2 1/2" x 5"  
Printed blue, yellow, red and black

V-302BB 4" x 36" • V-302C 3" x 24" • Printed red

# LIQUEFIED PETROLEUM GAS

Use the following legend for all signs and decals:

<b>M</b>	<b>Metal (Aluminum)</b>	<b>A</b>	<b>6" Letters</b>
<b>S</b>	<b>Scotchlite Brand Reflective</b>	<b>B</b>	<b>4" Letters</b>

<b>V</b>	<b>Vinyl (Self-adhesive)</b>	<b>BB</b>	<b>3" Letters</b>
<b>P</b>	<b>Plastic</b>	<b>C</b>	<b>2" Letters</b>
<b>G</b>	<b>Magnetic</b>	<b>D</b>	<b>1" Letters</b>



**M-99** 24" x 36"  
Cylinder filling sign  
Red and black printed

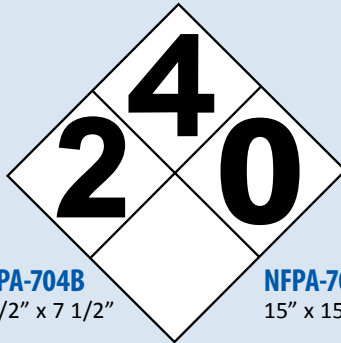

**NFPA-704B**  
7 1/2" x 7 1/2"

**NFPA-704A**  
15" x 15"

NFPA warning storage tanks  
Red, yellow, blue and black on white vinyl

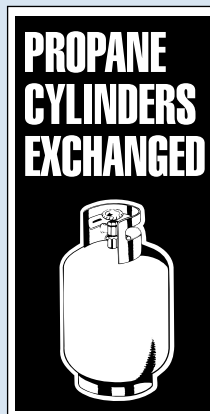
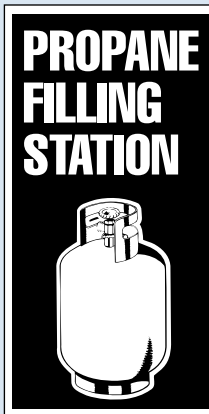

PART NO.	DESCRIPTION
M-93AX	Propane Exchange 2' x 4' Single Face*
M-93AX-D	Propane Exchange 2' x 4' Double Face*
M-97A	Propane Fill 2' x 4' Single Face*
M-97A-D	Propane Fill 2' x 4' Double Face*
M-97-D	In Spanish
M-97B	Propane Fill 3' x 6' Single Face*
M-97-BD	Propane Fill 3' x 6' Double Face*
M-97-FR	Frame Floor Style 2' x 4' with hardware
SF-1	Frame Ground Style 2' x 4'

\* Printed blue

**ALL GATES MUST BE OPEN BEFORE FILLING**

**M632** 27 1/2" x 5 1/2"  
Metal Gate Sign • Printed red

**Does your valve look like this?**

If not, it may not comply with national fire and safety standards. The handwheel pictured is part of an "OPD": Overfilling Prevention Device. An OPD is a safety feature that helps reduce the number of cylinders overfilled. Overfilling of cylinders can result in the release of propane through the relief valve when the propane expands through heating. It can also create higher pressure delivery to appliances through the piping system.

**Here's the facts you need to know!**

- ◆ 4# - 40# new cylinders\* manufactured after October 1, 1998 must have the OPD. The manufacture date is stamped on the cylinder collar.
- ◆ 4# - 40# cylinders\* requalified after October 1, 1998 must have the OPD installed. Requalification is required 12 years after manufacture date and every 5 years thereafter.
- ◆ After April 1, 2002, all cylinders\* must have OPDs and cannot be refilled without them.

\*Exception: All cylinders used in industrial truck service (including forklift truck cylinders) and/or those used for extensive welding and cutting gases are exempt from these requirements.

**Be safe!**  
Call your propane dealer now to get your cylinder fitted with the OPD.

Copyright Douglas Screen Printers, Inc. 1998 Call 1-800-888-8845 and ask for catalog number 11-P-111

**P-111** 16" x 20" OPD alert sign  
4 holes and 2 colors  
Printed red and blue

**Safety is You!**

**SAFETY PROCEDURES FOR FILLING DOT (ICC) AND ASME LP-GAS CONTAINERS**

- Filling Station must be installed and maintained in compliance with local, state and national regulations.
- Remove all combustible litter including dry leaves from within 10' of installation.
- Container filling must not be done within 20' of buildings and line of adjoining property that may be built upon and 20' of exposure of ignition.

**PRIOR TO STARTING FILLING PROCEDURE**

- If filling station is fenced, open both gates.
- All sources of ignition with 25' must be turned off.
- Vehicles with permanently mounted storage tanks must be at least 10' from 2000 GWC tanks during filling. All sources of ignition must be turned off.
- NO SMOKING within 20' of filling operation or equipment.
- Use protective gloves while filling cylinders.
- Fill only the following DOT (ICC) specification cylinders equipped with LP-gas service valves: 4B-240, 4BA-240, 4BW-240, 4B-240, 3B-340.
- Check cylinder for dents, excessive corrosion, leaks at fittings or valves, operable pressure relief device and current DOT regulations. Current regulations require requalification after 12 years if no letter indicates test date (i.e. 12-7-01); 7 years for "E" denoted test date; and 5 years for "E" denoted test date.
- Check tare weight (T.W.) of empty cylinder and water capacity (W.C.), both of which are stamped on cylinder or collar.
- Determine propane capacity from table shown. For other capacities not shown, multiply by .45.

W.C. (lbs)	Propane Capacity (lbs)	W.C. (lbs)	Propane Capacity (lbs)
12	8	72	50
15	10	80	53.9
24	16	90	60
26	18	104	69.8
40	28	120	80
60	42	144	100
67	47	220	150
89	59		

- Add T.W. and propane capacity together to determine total filled wt. of cylinder.
- Set scales to indicate this sight, plus hose & connector.

©2004 ASME SAFETY CENTER, INC. 1-800-888-8845

**V-123** 11" x 12"  
Safety procedures for filling DOT cylinders  
Printed red

**RECOMMENDED PROCEDURES FOR FILLING DOT (ICC) AND ASME LP-GAS CONTAINERS**

KEEP ALL COMBUSTIBLE MATERIAL AT LEAST 10' FROM TANK AND FILLING AREA.

**REMOVE EXCESSIVE LITTER**

- Remove all combustible litter including dry leaves from within 10' of installation.
- Remove all sources of ignition with 25' must be turned off.
- Vehicles with permanently mounted storage tanks must be at least 10' from 2000 GWC tanks during filling. All sources of ignition must be turned off.
- NO SMOKING within 20' of filling operation or equipment.
- Use protective gloves while filling cylinders.
- Fill only the following DOT (ICC) specification cylinders equipped with LP-gas service valves: 4B-240, 4BA-240, 4BW-240, 4B-240, 3B-340.
- Check cylinder for dents, excessive corrosion, leaks at fittings or valves, operable pressure relief device and current DOT regulations. Current regulations require requalification after 12 years if no letter indicates test date (i.e. 12-7-01); 7 years for "E" denoted test date; and 5 years for "E" denoted test date.
- Check tare weight (T.W.) of empty cylinder and water capacity (W.C.), both of which are stamped on cylinder or collar.
- Determine propane capacity from table shown. For other capacities not shown, multiply by .45.
- Add T.W. and propane capacity together to determine total filled wt. of cylinder.
- Set scales to indicate this sight, plus hose & connector.

**DO NOT FILL CYLINDERS BY WEIGHT ALREADY**

©2004 ASME SAFETY CENTER, INC. 1-800-888-8845

**V-206 White** 14" x 21 1/4"  
**P-206 Blue** 14" x 21 1/4"  
Printed red

**NO SMOKING within 25' of filling**

**Filling Procedures ASME (Perm Mounted) Containers**

- Only ASME containers having a minimum design pressure of 250 PSI or 200 PSI under U-68 or U-69 may be filled.
- Check that container is not already full to proper loading point (is there a cloud of visible vapor discharging from the fixed liquid level gauge vent valve?).
- Open liquid outlet valve on storage tank and fill in by-pass return line.
- Connect hose to container fill valve.
- Start pump.
- Open vent valve of fixed liquid level gauge.
- Open valve on end of hose.
- If container fill valve is hand operated, open valve.
- Fill until vapor coming from vent valve is visible, then immediately turn off hose and valve and close vent valve.
- Shut off pump.
- Turn off container valve if hand operated.
- Disconnect hose.
- Check container valves for leaks.

**WHEN FILLING IS COMPLETED OR WHEN STATION IS UNATTENDED**

- Shut off pump.
- Close valves at storage tank.
- Coil hose on rack inside fence protected area and install dust cap or plug in hose filling adaptor.
- Lock fence protected area to secure installation against tampering.

©2004 ASME SAFETY CENTER, INC. 1-800-888-8845

**V-122** 11" x 12"  
Printed red



**12-A-53** 5" x 1 1/4"  
Warning Decal  
Printed black

## NO SMOKING

**CAUTION! Follow This Procedure To Fill Tank.**

1. Turn engine ignition off.
2. Attach liquid line to tank (& vapor if used).
3. Open storage tank valve.
4. Open hose valve.
5. Open 20% gauge on vehicle tank.
6. Start pump.
7. Stop filling when liquid appears at 20% gauge.
8. Close hose valve.
9. Shut 20% gauge on vehicle tank.
10. Shut off pump.
11. Disconnect liquid hose (& vapor if used).
12. Close storage tank valve.

## NO SMOKING

V-30 15" x 22" • Printed red and black



## Filling Procedure Portable Cylinders

1. Open liquid outlet valve on storage tank and valves in by-pass return line.
2. Connect hose to cylinder fill valve.
3. Start pump.
4. Open valve on cylinder.
5. Open valve on end of hose.
6. Close hose valve as soon as scale beam or indicator tips.
7. Close cylinder valve.
8. Disconnect hose.
9. Check weight. Bleed off overfill at a safe location.
10. Check container valves for leaks.

**OPERATOR MUST BE IN ATTENDANCE DURING ENTIRE FILLING PROCEDURE.**

DECKARD'S SIGN SYSTEM, INC. 800-888-8343

V-121 11" x 12" • Printed red

## Do you have your OPD yet?

The Overfill Prevention Device (OPD) is a float-activated device designed to assist propane refilling to safe levels. To comply with new codes, most consumer-style propane cylinders need to be equipped with the OPD.

**Your cylinder may need an OPD as early as March, 1998!**

For your safety the NFPA (National Fire Protection Association) has enacted the following code change. Please read below to see if your cylinder is eligible for this code modification:

- All DOT cylinders sizes 48 to 600 require an OPD. (Excludes any Forthright, Welding and Cutting Gas cylinders.)
- Eligible DOT cylinders will receive an OPD Valve at DOT recertification beginning April 1998 through March, 2002. Recertification is a routine mechanical inspection that makes sure all components of a cylinder are free from defective parts and/or contaminants.
- OPD recertification of a cylinder is required 1 year after the date of original recertification, then every 4 years thereafter. (Photo is left demonstrates where an OPD fills date stamp. Its recertification date also appears here.)
- In April, 2002, all eligible cylinders will require an OPD Valve before filling.

**How to tell if your cylinder already has an OPD Valve:**

Questions about your OPD valve? Ask your local propane distributor, or contact the consumer hotline: 1-800-296-0194

S35483 18" x 24"

OPD metal sign explains the new regulations for 4-40lb cylinders.



S-500 3" x 4 1/2"  
Diamond • Black on reflective with application instructions.

### OUR COMPANY IS CONCERNED FOR YOUR SAFETY

THE EMPLOYEE FILLING THIS PROPANE CYLINDER IS CERTIFIED BY ALL LOCAL, STATE & FEDERAL REGULATIONS TO FILL & MAKE A VISUAL INSPECTION IN ACCORDANCE WITH NFPA 58 STANDARDS & MGA SAFETY BULLETIN NO 118 PLEASE BY LAW NO EXCEPTION

<p>✓ PROTECTIVE COLLAR DOT 2 CYLINDERS WITHOUT COLLAR ARE NOT APPROVED FOR REFILL.</p>	<p>✓ EXCESSIVE RUST DOT 2 CYLINDERS WITH EXCESSIVE RUST ARE NOT APPROVED FOR REFILL.</p>
<p>✓ FOOT RING DOT 2 CYLINDERS WITHOUT FOOT ARE NOT APPROVED FOR REFILL.</p>	<p>✓ DOT LABELS DOT 2 CYLINDERS WITHOUT PROPERLY PLACED DOT LABEL ARE NOT APPROVED FOR REFILL.</p>
<p>✓ GAS VALVE DOT 2 CYLINDERS WITH A REST OR BUSTED GAS VALVE ARE NOT APPROVED FOR REFILL.</p>	<p>✓ POL PLUG FOR VALVE DOT 2 CYLINDERS WITHOUT POL PLUG ARE NOT APPROVED FOR REFILL.</p>
<p>✓ EXCESSIVE DENTS DOT 2 CYLINDERS WITH EXCESSIVE DENTS OR DENTS WITH AN INFERIOR FINISH ARE NOT APPROVED FOR REFILL.</p>	<p>✓ OK CYLINDERS WITH A PROTECTIVE COLLAR, FEET AND BENT GAS VALVE, FEET AND BENT POL PLUG, FEET AND BENT POL PLUG FOR VALVE ARE APPROVED FOR REFILL.</p>

**NOTE:** OVER FILLING OF PROPANE CONTAINER IS IN VIOLATION OF STATE AND FEDERAL LAWS. STATE LAW PROHIBITS THE USE OF PROPANE CYLINDERS FOR REFILL MUST HAVE A VISUAL, EXTERNAL INSPECTION BY A CERTIFIED PROPANE DEALER 12 YEARS AFTER DATE OF MANUFACTURE AND EVERY 5 YEARS THEREAFTER.

**REFERENCE:** DOT AS PUBLISHED IN CODE OF FEDERAL REGULATIONS TITLE 49 PARTS 180-180 SPECIFICATIONS DOT ICC 48.84A, 48.84E AND 26-3000 CYLINDERS WHEN USED IN PROPANE GAS SERVICE.

**LAWS ARE MADE FOR YOUR SAFETY - LIVE CAREFULLY**

V-21, P-21  
18" x 24"

Printed red and black

P-21G

18" x 24"

Printed red and black  
Includes Grommets

## EXCHANGE CHECKLIST

TO ASSURE YOUR SAFETY AND PROPER OPERATION, ALL PROPANE EXCHANGE CYLINDERS MUST MEET LOCAL, STATE & FEDERAL REGULATIONS, IN ACCORDANCE WITH NFPA 58 STANDARDS & MGA SAFETY BULLETIN NO 118 PLEASE BY LAW NO EXCEPTION

<p>✓ PROTECTIVE COLLAR DOT 2 CYLINDERS WITHOUT COLLAR ARE NOT APPROVED FOR REFILL.</p>	<p>✓ EXCESSIVE RUST DOT 2 CYLINDERS WITH EXCESSIVE RUST ARE NOT APPROVED FOR REFILL.</p>
<p>✓ FOOT RING DOT 2 CYLINDERS WITHOUT FOOT ARE NOT APPROVED FOR REFILL.</p>	<p>✓ DOT LABELS DOT 2 CYLINDERS WITHOUT PROPERLY PLACED DOT LABEL ARE NOT APPROVED FOR REFILL.</p>
<p>✓ GAS VALVE DOT 2 CYLINDERS WITH A REST OR BUSTED GAS VALVE ARE NOT APPROVED FOR REFILL.</p>	<p>✓ POL PLUG FOR VALVE DOT 2 CYLINDERS WITHOUT POL PLUG ARE NOT APPROVED FOR REFILL.</p>
<p>✓ EXCESSIVE DENTS DOT 2 CYLINDERS WITH EXCESSIVE DENTS OR DENTS WITH AN INFERIOR FINISH ARE NOT APPROVED FOR REFILL.</p>	<p>✓ OK CYLINDERS WITH A PROTECTIVE COLLAR, FEET AND BENT GAS VALVE, FEET AND BENT POL PLUG, FEET AND BENT POL PLUG FOR VALVE ARE APPROVED FOR REFILL.</p>

**NOTE:** OVER FILLING OF PROPANE CONTAINER IS IN VIOLATION OF STATE AND FEDERAL LAWS. STATE LAW PROHIBITS THE USE OF PROPANE CYLINDERS FOR REFILL MUST HAVE A VISUAL, EXTERNAL INSPECTION BY A CERTIFIED PROPANE DEALER 12 YEARS AFTER DATE OF MANUFACTURE AND EVERY 5 YEARS THEREAFTER.

**REFERENCE:** DOT AS PUBLISHED IN CODE OF FEDERAL REGULATIONS TITLE 49 PARTS 180-180 SPECIFICATIONS DOT ICC 48.84A, 48.84E AND 26-3000 CYLINDERS WHEN USED IN PROPANE GAS SERVICE.

**FOR SERVICE PLEASE CALL - LIVE CAREFULLY**

C-37G  
Coroplast  
12" x 24"

V-14  
12" x 16"  
Printed red and black

### HAZARDOUS MATERIAL SHIPPING PAPER

#### UN 1075 Liquefied Petroleum Gas 2.1 (Flammable Gas)

Product: (Non-Corrosive)  
Volume: "One Truck Load"

EMERGENCY CONTACT (NAME/NUMBER) -  
ERI PROVIDER - (NAME/NUMBER)

POTENTIAL HAZARDS  
**FIRE OR EXPLOSION**  
EXTREMELY FLAMMABLE. Will be easily ignited by heat, sparks or flames. Will form explosive mixtures with air. Vapors from liquid can form explosive mixtures with air and spread along ground.  
CAUTION: Hydrogen (581048), Deuterium (581922), and Methane (581971) are lighter than air and will rise. Hydrogen and Deuterium may be difficult to detect since they burn with an invisible flame. Use an alternate method of detection (thermal camera, infrared bands, etc.)

**HEALTH**  
Inhalation may cause dizziness or respiratory irritation without warning. Some may be sensitive if inhaled at high concentrations. Contact with gas or liquid may cause burns, severe injury and/or frostbite. Fire may produce irritating and/or toxic gases.

**PUBLIC SAFETY**  
CALL Emergency Response Telephone Number on Shipping Paper First, if Shipping Paper not available or no answer, refer to appropriate telephone number listed on the inside back cover of the 2004 Emergency Response Guidebook. As an authorized personnel, always wear eye protection when handling or filling cylinders. Do not spray liquid or gas directly on face, neck, or hands. Do not use compressed gas for cleaning, breathing, or fire fighting. Do not use compressed gas for lifting. Do not use compressed gas for blowing dust or debris. Do not use compressed gas for blowing dirt or debris. Do not use compressed gas for blowing paint or coatings. Do not use compressed gas for blowing liquid or solids. Do not use compressed gas for blowing dust or debris.

**PROTECTIVE CLOTHING**  
Wear protective clothing and equipment when handling or filling cylinders. Do not use compressed gas for cleaning, breathing, or fire fighting. Do not use compressed gas for blowing dust or debris.

**EVACUATION**  
Large Spill - Consider initial downwind evacuation for at least 500 meters (0.5 mile).  
Fire - If tank, rail car or tank truck is involved in a fire, ISOLATE for 1600 meters (1 mile) in all directions; also, consider initial evacuation for 1600 meters (1 mile) in all directions.

**FIRE**  
DO NOT EXTINGUISH A LEAKING GAS FIRE UNLESS LEAK CAN BE STOPPED.  
CAUTION: Hydrogen (581048) and Deuterium (581922) burn with an invisible flame.  
Small Fire - Dry chemical or CO<sub>2</sub>.  
Large Fire - Water spray or fog. Never use water from fire area if you do not know what it is.  
Fire Involving Tank - Fight fire from maximum distance or use unmanned hose holders or monitor nozzles. Cool containers with flooding quantities of water until well after fire is out. Do not direct water at base of tank or safety devices. Do not use water to extinguish. Do not use water to extinguish. Do not use water to extinguish. Do not use water to extinguish. Do not use water to extinguish.

**SPILL OR LEAK**  
ELIMINATE all ignition sources (no smoking, flames, sparks or flames) in immediate area. All equipment used when handling the product must be grounded. Do not touch or walk through spilled material. Stop leak if you can do it without risk. If possible, turn leaking container so that gas escapes rather than liquid. Use water spray to reduce vapor or divert vapor down drift. Avoid allowing water to wash to confined spaces. Do not direct water at base of tank. Prevent spreading of vapor through screens, ventilation systems and confined areas. Isolate area until gas has dispersed.

**CAUTION:** When in contact with refrigeration systems, liquid, very materials become brittle and are likely to break without warning.

**FIRST AID**  
Breathing In - If inhaled, call 911 for emergency medical services. Use artificial respiration if victim is not breathing. Administer oxygen if breathing is difficult. Breathing irritant, move victim to fresh air. Do not use mouth-to-mouth respiration. If victim is not breathing, use artificial respiration. In case of contact with liquid or gas, flush with water. Do not use mouth-to-mouth respiration. Do not use mouth-to-mouth respiration. Do not use mouth-to-mouth respiration.

Marked by DSP 800-888-8343 Emergency Response Guidebook NERG-2008-Guide 115 Cal. P-83 06-10

V-83 7" x 8 1/2"  
Printed red

V-83-CYL 7" x 8 1/2"  
Printed red

CG-126FO  
13 1/2" x 13 1/2"  
1075 Flipover sign

80SM  
Placard holder  
Aluminum

CG-126FO  
13 1/2" x 13 1/2"  
1075 Flipover sign

80SM  
Placard holder  
Aluminum



Use the following legend for all signs and decals:

<b>M</b>	<b>Metal (Aluminum)</b>	<b>A</b>	<b>6" Letters</b>
<b>S</b>	<b>Scotchlite Brand Reflective</b>	<b>B</b>	<b>4" Letters</b>

<b>V</b>	<b>Vinyl (Self-adhesive)</b>	<b>BB</b>	<b>3" Letters</b>
<b>P</b>	<b>Plastic</b>	<b>C</b>	<b>2" Letters</b>
<b>G</b>	<b>Magnetic</b>	<b>D</b>	<b>1" Letters</b>



**M5291** 8" x 2 1/4"  
White arrow on red



**M5291WR** 8" x 2 1/4"  
White arrow on green



**S-22B** 4" x 36"  
Reflective Railroad Crossing  
Printed red



**S-29** 4" x 36"  
Reflective Scotchlite  
Printed red



**S-22C** 8" x 12"  
Printed white on red



**11-V-128** 3 3/4" x 4"  
Printed red

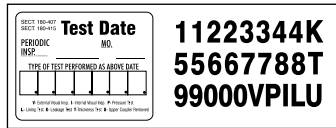

**V-31** 6" x 18"  
Periodic Inspection Kit (Test Date)  
The decal on left of kit sheet is 5 1/4" x 6 1/2". This applies to tank. The numbers are removed from the right and placed in the slots provided for dates and letters for test performed. All parts on kits are thermal die cut for individual removal of part. Printed black

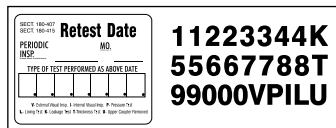

**V-32** 6" x 18"  
5 Year Inspection Kit (Retest Date)  
Printed black



**P-138**  
4" x 12"  
Printed white on red.

CYLINDER FILLING CAPACITY CHART			
W.C.	LBS. PROPANE	W.C.	LBS. PROPANE
2.39	1	35.8	15
4.78	2	38.2	16
7.17	3	40.6	17
9.56	4	43.0	18
11.9	5	45.4	19
14.3	6	47.8	20
16.7	7	59.7	25
19.1	8	71.7	30
21.5	9	78.8	33
23.9	10	83.6	35
26.2	11	95.6	40
28.6	12	105.1	44
31.0	13	119.5	50
33.4	14	239	100

**P-101** 12 1/4" x 12"  
Printed red/blue

### LP Gas



PART NO.	DESCRIPTION
V-1075	Vinyl 1075
P-1075	Poly 1075
G-1075	Magnetic 1075
M-1075	Metal 1075



### Residue

PART NO.	DESCRIPTION
V-1075-R	Vinyl 1075 Residue
P-1075-R	Poly 1075 Residue

10 3/4" x 10 3/4"  
Printed red and black

**V-52** Vinyl  
**P-52** Poly  
10 3/4" x 10 3/4"  
Printed red  
**V-59** 4" x 4"  
Printed red



MONTH	VISUAL REQUALIFIER IDENTIFICATION NUMBER	YEAR
1 2	V000000 E	09/10
3 4		11/12
5 6		13/14
7 8		15/16
9 10		17/18
11/12		19/20

DSP-5-C163

**5-C163** 3" x 1.8756"  
Black on White Vinyl

This tank has been visually reinspected in accordance with 49 CFR 180.209(g)	
<input type="text"/>	Visual Requalifier Identification Number
<input type="text"/> / 05 E	Date/Type of Visual Inspection

5-C86

**5-V86** 3" x 1.8756"  
Black on White Vinyl

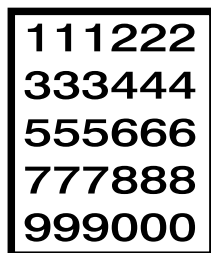

**V-33** Number Sheet Only  
Test/Retest kits for NQT/QT.  
Each kit contains 2 thermal die-cut sheets, shown below.  
Printed black



**V-66**  
6 1/2" x 2 3/4"  
Printed red



**V-65**  
4 1/2" x 2 3/4"  
Printed red

DOT Cylinder Requalification Record			
RIN	Original Inspection	Second Inspection	Third Inspection
<input type="text"/>	<input type="checkbox"/> / <input type="checkbox"/>	<input type="checkbox"/> / <input type="checkbox"/>	<input type="checkbox"/> / <input type="checkbox"/>
			Visual Inspection <b>E</b>

5-C87

**5-V87** 1.5" x 5.25"  
Black on White Vinyl

## Coro-Flo Pumps (C-Model)

### Standard Close-Coupled Coro-Flo Pumps with Starters

MODEL NUMBER	DESCRIPTION
C10FD2A SM-30	Close-coupled pump with 2 hp continuous duty, fan cooled motor and motor mounted starter. (a)
C10FD2A S-30	Close-coupled pump with 2 hp continuous duty, fan cooled motor and separate remote wall mounted starter. (a)
C12FD2A SM-30	Close-coupled pump with 2 hp continuous duty, fan cooled motor and motor mounted starter. (a)
C12FD2A S-30	Close-coupled pump with 2 hp continuous duty, fan cooled motor and separate remote wall mounted starter. (a)
C13FD2A SM-30	Close-coupled pump with 2 hp continuous duty, fan cooled motor and motor mounted starter. Motor starter provides heavy duty switch. (a)
C13FD2A S-30	Close-coupled pump with 2 hp continuous duty, fan cooled motor and separate remote wall mounted starter. Motor starter provides heavy duty switch. (a)

(a) These motors are listed by Underwriters' Laboratories, Inc. and CSA for Class 1, Group D, explosion-proof service.

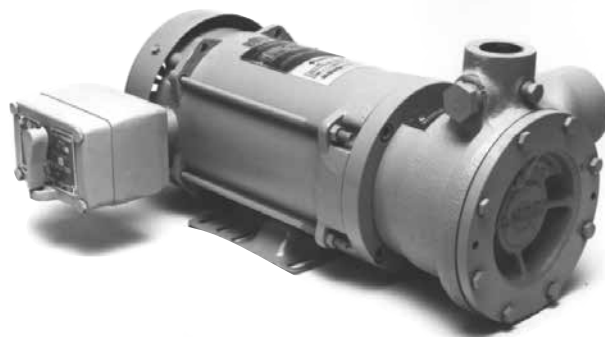

### Accessory Options

PART NUMBER	DESCRIPTION
B166B-.75BAU-Y	3/4" bypass valve purchased with C-Model pump
B166B-1BAU-Y	1" bypass valve purchased with C-Model pump

### Part Options

PART NUMBER	DESCRIPTION
113-CXA	Mechanical seal (Buna-N)
2555	3/4 hp, 60 Hz Coro-Flo motor (REPLACED BY PART #2556)
2556	1 hp, 60 Hz Coro-Flo motor
4261	2 hp, 50/60 Hz Coro-Flo motor
2557	3hp, 50/60 Hz Coro-Flo motor

### Electrical Options

PART NUMBER	DESCRIPTION
2277-X1*	Motor mounted manual starter
2277-X2*	Wall mounted manual starter
2277-X3	Motor mounted manual starter-2 hp
2275-X1	Switch assembly with heater- 3/4 hp
2275-X2	Switch assembly with heater-1 hp
2275-X3	Switch assembly with heater-2 hp

## Models C9 to C14-Parts Details

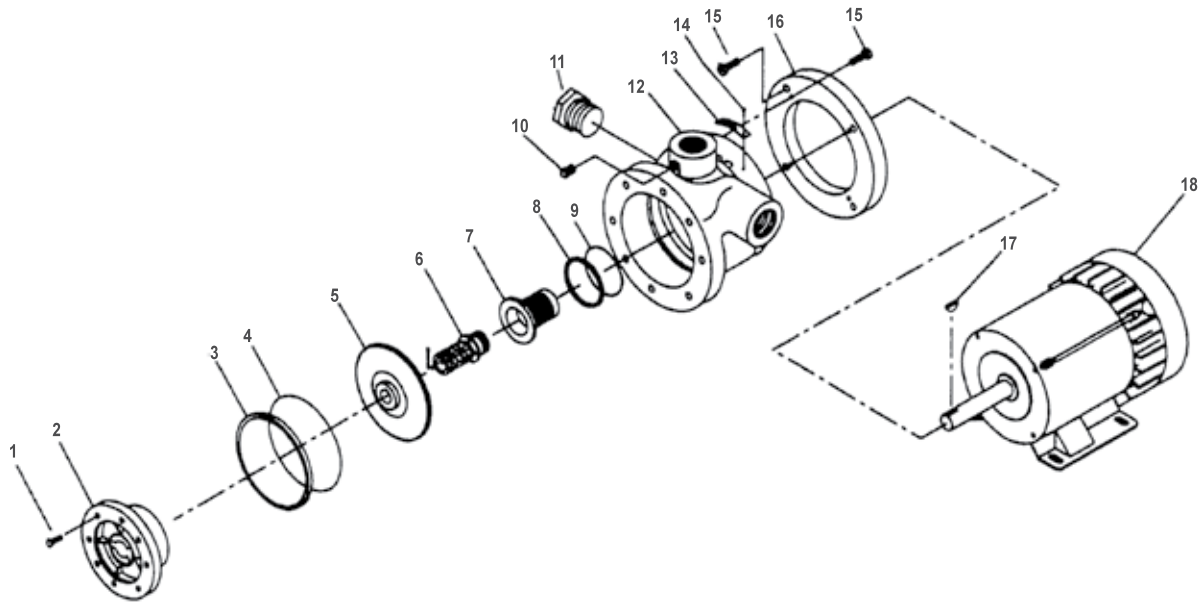

CAUTION: Always relieve pressure in the unit before attempting any repairs.

REF NO.	PART NO.	DESCRIPTION	QTY
1	7001-031NC100A	Hex head cap screw	8
2	1001-09	Cover—model 9	1
	1001-0	Cover—model 10	1
	1001-2	Cover—model 12	1
	1001-3	Cover—model 13	1
	1001-4	Cover—model 14	1
	1001-5	Cover—model 15	1
3	1014	Case clearance shim (.002" red)	As req.
	1014-1	Case clearance shim (.003" green)	As req.
4	2-246_	Case O-ring (non-Teflon®)	1
	2-247E	Case O-ring Teflon®	1
5	1003-09	Impeller, brass—model 9	1
	1003-0	Impeller, brass—model 10	1
	1003-2	Impeller, brass—model 12	1
	1003-3	Impeller, brass—model 13	1
	1003-4	Impeller, brass—model 14	1
	1003-5	Impeller, brass—model 15	1
6	113-CX_	Seal assembly	1
7	1004-1X	Seal housing, steel (non-Teflon® O-rings)	1
	1004-11X	Seal housing, SS (non-Teflon® O-rings)	1
	1004-2X	O-rings	1
	1004-21X	Seal housing, steel (Teflon® O-rings)	1
	1004-21X	Seal housing, steel (Teflon® O-rings)	1
8	1013	Housing adjustment shim (0.010")	1
	1013-1	Housing adjustment shim (0.020")	1

REF NO.	PART NO.	DESCRIPTION	QTY
9	2-224_	Housing O-ring	1
10	3442	Pipe plug, 1/4" NPT	1
11	3444	Pipe plug, 3/4" NPT	1
12	1002-09	Case—model 9	1
	1002-0	Case—model 10	1
	1002-2	Case—model 12	1
	1002-3	Case—model 13	1
	1002-4	Case—model 14	1
	1002-5	Case—model 15	1
13	1914-1	Nameplate	1
14	7012-006SF019E	Phillips head screw 6-32 X 1/4"	2
15	7002-037NC087A	Socket head cap screw	8
16	1015	Adapter ring	1
	2497	Woodruff key, steel	1
17	2497-1	Woodruff key, SS	1
	2555	Motor 3/4 hp models 9, 10	1
18	2556	Motor 1 hp model 12	1
	2557	Motor 3 hp models 14, 15	1
	2895	Motor 3/4 hp, obsolete models 9E, 10	1
	2896	Motor 1 1/2 hp, obsolete model 12E	1
	4261	Motor 2 hp model 13	1

### Balanced Seal Assembly 113-CX

Models C9 to C15, DS/DL9 to DS/DL15, F9 to F15, F109 to F115

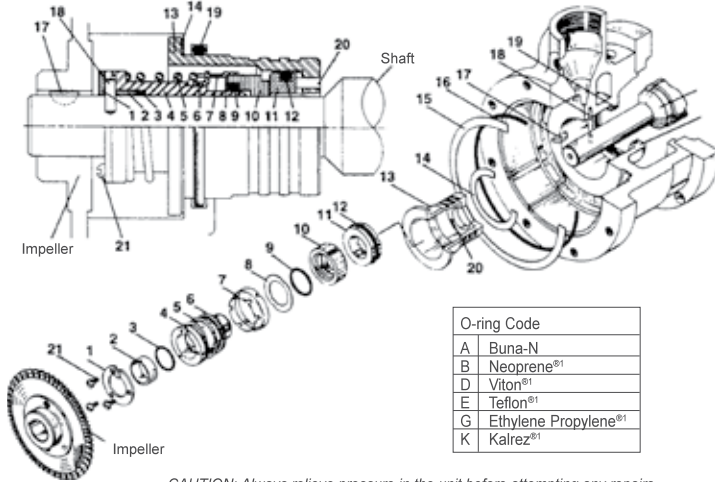

CAUTION: Always relieve pressure in the unit before attempting any repairs.

ASSEMBLY NO.	ASSEMBLY NAME
113-CX_	Seal assembly with 1007-X, 1008, 1009, 1014, 1014-1, 1080, 2497, 2736, 2737, 2739-X, 2-018, 2-224, 2-246
1007-X	Seal sleeve assembly with 1007, 2734, 2735
1007-2X	Seal sleeve assembly, stainless steel, with 1007-2, 2734, 2735
2739-X_	Rotor-seat assembly, cast iron, with 2738, 2739, 2-118, 2-216
2739-1X_	Rotor-seat assembly, ceramic, with 2738, 2739-1, 2-118, 2-216
2739-2X_	Rotor-seat assembly, ni-resist, with 2738, 2739-2, 2-118, 2-216
2739-3X_	Rotor-seat assembly, stainless steel, with 2738, 2739-3, 2-118, 2-216
2739-4X_	Rotor-seat assembly, tungsten carbide, with 2738, 2739-4, 2-118, 2-216

REF NO.	PART NO.	DESCRIPTION	QTY
1	1008	Seal clamp ring	1
2	1080	Follower, aluminum	1
	1080-1	Follower, stainless steel	1
3	2-018_	Follower O-ring	1
4	1007	Seal sleeve, aluminum	1
	1007-2	Seal sleeve, stainless steel	1
5	2734	Spring	1
6	2735	Driveband	1
7	2736	Retainer	1
8	2737	Disc	1
9	2-118_	Rotor O-ring	1
	2343-X	Coro-seal (not shown)	1
11	2739	Seat, cast iron	1
	2739-1	Seat, ceramic	1
	2739-2	Seat, ni-resist	1
	2739-3	Seat, stainless steel	1
	2739-4	Seat, tungsten carbide	1
12	2-216_	Seat O-ring	1
13	1004-1X	Seal housing, steel (with pin)	1
	1004-11X	Seal housing, stainless steel (with pin)	1
	1004-2X	Seal housing, steel	1
	1004-21X	Seal housing, stainless steel	1
14	1013	Housing adjustment shim (0.010")	As req.
	1013-1	Housing adjustment shim (0.020")	As req.
15	1014	Case clearance shim (0.002)	As req.
	1014-1	Case clearance shim (0.020)	As req.
16	2-246	Case O-ring (Non-Teflon <sup>®</sup> )	1
	2-247E	Case O-ring, Teflon <sup>®</sup>	1
17	2497	#5 Woodruff key, steel	1
	2497-1	#5 Woodruff key, stainless steel	1
18	1009	Seal drive pin	1
19	2-224_	Seal housing O-ring	1
20	3520	Roll pin (included with seal housing)	1
21	7012-006NC025B	Screw, 6-32 x 1/4" phillip pan head	3

### Coro-Flo Pump Motors-Parts Details

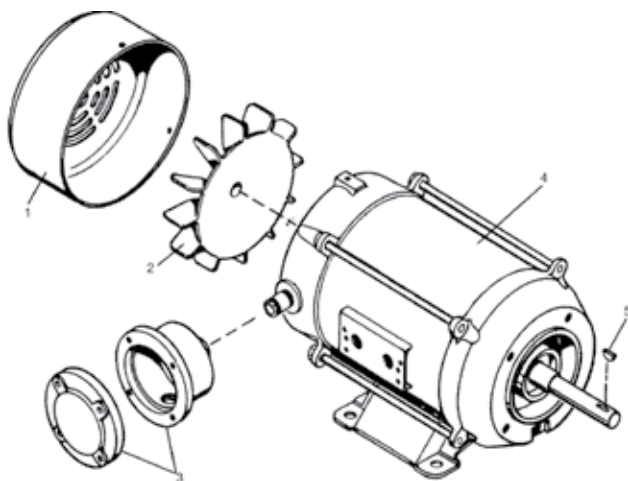

REF NO.	PART NO.	DESCRIPTION
1	2660-2	Fan guard, Franklin (models C9, C10, C12)
2	3547	Fan—Franklin (models C9, C10, C12)
3	2686-X	Conduit box assembly (model C14 only)
4	2555	Motor—3/4 hp (models C9, C10)
	2556	Motor—1 hp (model C12)
	2557	Motor—3 hp (model C14)
	4261	Motor—2 hp (model C13)
5	2497	Key

CAUTION: Always relieve pressure in the unit before attempting any repairs.

CAUTION: To help prevent shock or ignition of hazardous atmospheres, always disconnect and lock out power circuit.

## Z-Series Stationary Pumps

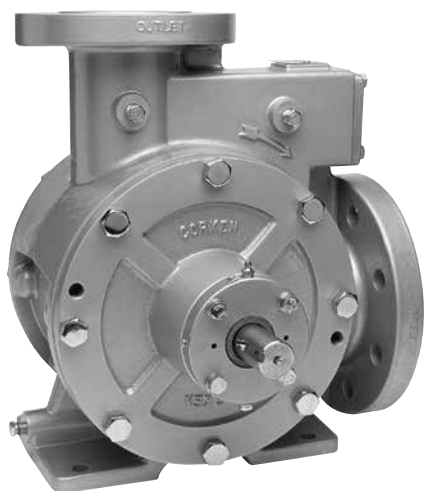

### Coro-Vane Pumps

PART NUMBER	INLET	OUTLET	INTERNAL RELIEF VALVE
521	2 1/2" NPT	2" NPT	Yes
1021	3" NPT	3" NPT	Yes
F1021	3" ANSI 300 lb.	2 1/2" ANSI 300 lb.	No
Z2000	2" NPT	2" NPT	Yes
Z3500	3" NPT	3" NPT Elongated	Yes
Z4500	4" ANSI 300 lb.	3" ANSI 300 lb.	Yes

### Part Options

PART NUMBERS	DESCRIPTION	MODEL NUMBER
2904-X2	Recommended Repair Kit - LPG/NH3 - Includes seals, blades, sideplates, bearings and gaskets	521
2906-X2		1021, F1021
2907-X3		F1521
3195-X2	Recommended Repair Kit - LPG/NH3 - Includes seals, blades, bearings and gaskets	Z3500
3197-X1		Z4500

### Standard Mounting Options

PART NUMBER	DESCRIPTION	MODEL REFERENCE	MAX. DRIVER SIZE (HP)
103-9-	Mounting set-up for <b>V-Belt Drive</b> . Includes steel baseplate, adjustable motor slide base, V-belt drive and enclosed beltguard. PUMP AND MOTOR NOT INCLUDED	521 Z2000	254T (w/521)
			254T (Z2000)
103-10-		184T (w/1021)	
		184T (w/F1021)	
		184T (w/Z3500)	
		215T (w/1021)	
		215T (w/F1021)	
		215T (w/Z3500)	
		284T (w/1021)	
284T (w/F1021)			
284T (w/Z3500)			
103-15-	Z4500	256T	
		284T	
102-	Mounting set-up for use with <b>Engine Driver</b> through " <b>V-Belt Drive</b> ". Includes steel baseplate, flexible coupling, and coupling guard. PUMP AND MOTOR NOT INCLUDED	521, Z2000, 1021, F1021	-

### Industrial Mounting Options

PART NUMBER	DESCRIPTION	MODEL REFERENCE	MAX. DRIVER SIZE (HP)
101GRB-	Mounting set-up for <b>Direct Drive</b> . Includes size "B" gear reducer, steel baseplate mounting, reducer bracket, couplings and coupling guard. PUMP AND MOTOR NOT INCLUDED	521	182T-254T
101GRB-		Z2000	182T-254T
101GRB-		1021	182T-254T
101GRB-		F1021	182T-254T
101GRB-		Z3500	182T-254T
101GRB-		Z4500	182T-254T
101GRC-		Mounting set-up for <b>Direct Drive</b> . Includes size "C" gear reducer, steel baseplate mounting, reducer bracket, couplings and coupling guard. PUMP AND MOTOR NOT INCLUDED	521
101GRC-	Z2000		213T-324T
101GRC-	1021		213T-324T
101GRC-	F1021		213T-324T
101GRC-	Z3500		213T-324T
101GRC-	Z4500		213T-324T

## Z-Series Stationary Pumps - Parts Details

### Models 521 and 1021

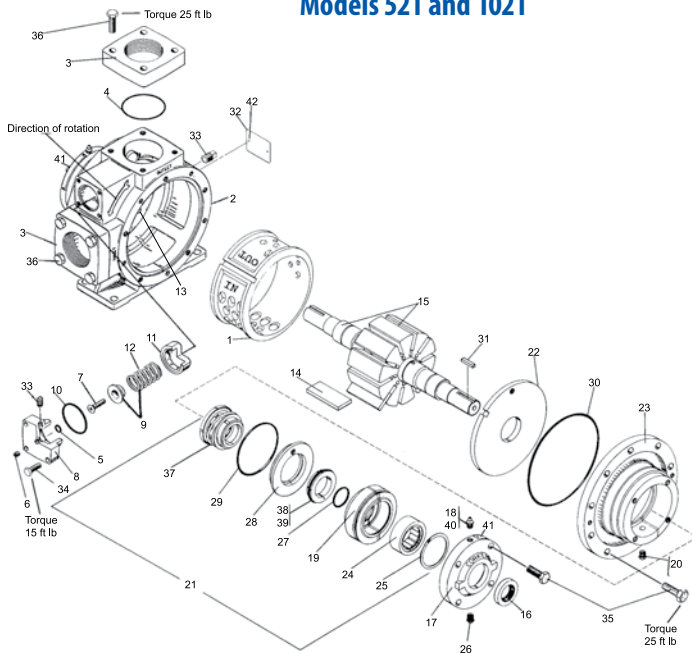

REF NO.	PART NO.	DESCRIPTION	QTY
1	1162-2 1201-2	Cam (521) Cam (1021)	1 1
2	2832 2841	Case (521) Case (1021)	1 1
3	1172-2.5	2.5" Flange (521) 2" Flange (521) 3" Flange (1021)	1 1 2
4	2-234_ 2-245_ 2-249_	Flange O-ring (521) Flange O-ring 3" (1021) Flange O-ring 4" (1021)	2 2 2
5	2-112_	Adjusting screw O-ring	1
6	2590	Flush seal plug 1/8" NPT	1
7	2252	Relief valve adjusting screw	1
8	1174 1207	Valve cap (521) Valve cap (1021)	1 1
9	1242-X 1227	Relief valve spring & guide (521) Relief valve spring & guide (1021)	1 1
10	2-224_ 2-228_	Relief valve cap O-ring (521) Relief valve cap O-ring (1021)	1 1
11	1241 1224	Relief valve (521) Relief valve (1021)	1 1
12	1242 1226	Relief valve spring (521) Relief valve spring (1021)	1 1
13	1170 1309	Cam key (521) Cam key (1021)	1 1

REF NO.	PART NO.	DESCRIPTION	QTY
14	1168-7 1308-9	Blade (521) Blade (1021)	10 10
15	1166-1X1R 1208-1X1R	Rotor & shaft assembly (521) Rotor & shaft assembly (1021)	1 1
16	1358	Grease seal	2
17	1164-1	Bearing cap	2
18	2158	Grease zerk 1/8" NPT	2
19	1769	Bearing housing	2
20	1343	Relief fitting (seal vent)	2
21	1769-X 1769-XR	Seal assembly Seal assembly—replacement	2 2
22	1163-2 1209-1	Sideplate (521) Sideplate (1021)	2 2
23	1161-4 1205-4	Head (521) Head (1021)	2 2
24	2754-X 2755 2754	Roller bearing—complete Bearing inner race Bearing outer race	2 2 2
25	2760-244	Retainer ring	2
26	1343	Relief fitting (grease)	2
27	2-128_	Shaft O-ring	2
28	1882	Seat adapter plate	2
29	2-240_	Adapter plate O-ring	2
30	2-261_ 2-268_	Case O-ring (521) Case O-ring (1021)	2 2
31	2270	1/4" Key	2
32	2949	nameplate	1
33	3442	1/4" NPT plug	1
34	7001-031 NC125A 7001-037 NC125A	Hex hd bolt 5/16-18x1-1/4 (521) Hex hd bolt 3/8-16x1-1/4 (1021)	4 4
35	7001-037 NC125A 7001-037 NC125A	Hex hd bolt 3/8-16x1-1/4 (521) Hex hd bolt 3/8-16x1-1/4 (1021)	28 32
36	7001-037 NC150A	Hex head bolt 3/8-16x1-1/2	8
37	-----	Retainer	2
38	-----	Seal seat	2
39	2-227_	Seal seat O-ring	2
40	2159	Lubricap #2	2
41	1359	Lubrication instruction tag	2
42	7003-004 DR0198	Round head plated drive screw 4 x 3/16	2

## Z-Series Stationary Pumps - Parts Details

### Models F1021

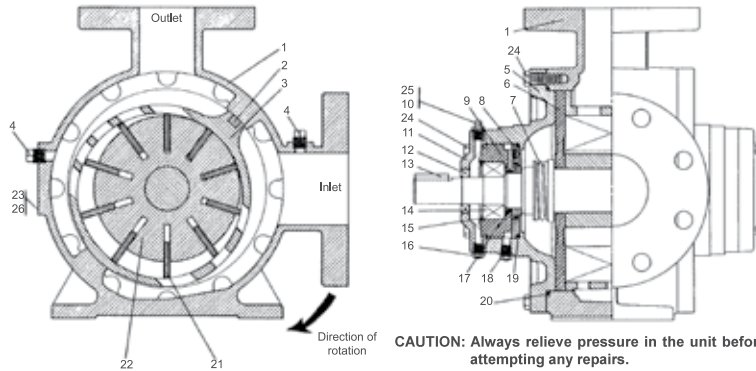

CAUTION: Always relieve pressure in the unit before attempting any repairs.

REF NO.	PART NO.	DESCRIPTION	QTY	REF NO.	PART NO.	DESCRIPTION	QTY
1	2433	Case	1	14	2754-X	Rikker bearubg—complete Bearing	2
2	1309	Cam key	1	2755		inner race	2
3	1201-2	Cam	1	2754		Bearing outer race	2
4	3442	1/4" NPT plug	2	15	2760-244	Retainer ring	1
5	1205-4	Head	2	16	1343	Relief fitting (grease)	2
6	1209-1 <sup>5</sup>	Sideplate	2	17	2-128_4	Shaft O-ring	1
7	1769-X <sub>1,2</sub> 1769-XR <sub>1,2</sub>	Seal Assembly Seal replacement kit	2 2	18	1343	Relief fitting (seal vent)	1
8	1822	Seat adapter plate	2	19	2-240_2	Adapter plate O-ring	1
9	1769	Bearing house	1	20	2-268_2	Case O-ring	2
10	2158	Grease zerk 1/8" NPT	1	21	1308-9	Vane	10
11	1164-1	Bearing cap	2	22	1208-1X1R	Rotor and shaft assembly with 2755	1
12	1358	Grease seal	1	23	2649	Nameplate	1
13	2270	1/4" Key	1	24	7001-037 NC125A	Hex hd bolt 3/8-16x1-01/4"	32
				25	2159	Lubricap #2	2
				26	7012-006 SF019E	Drive screw 6-32x3/16 pan head	6

## Z-Series Truck Pumps

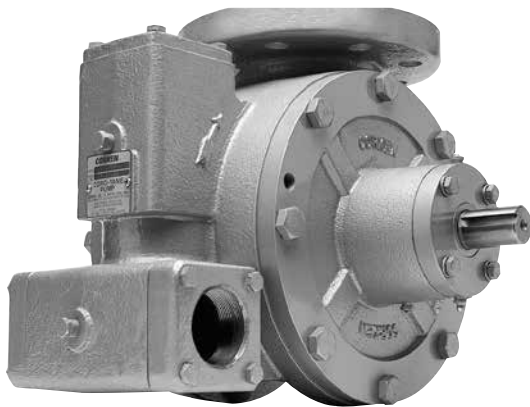

### Part Options – Repair/Rebuild Kits Etc.

PART NUMBER	DESCRIPTION	MODEL REFERENCE
2904-X2	Recommended Repair Kit* - LPG/NH <sub>3</sub> Includes seals, blades, sideplates, bearings and gaskets.	522
2906-X2		1022
3193-X1	Recommended Repair Kit* - LPG/NH <sub>3</sub> Includes seals, blades, blade drivers, bearings and gaskets.	Z2000, ZH2000, ZX2000, ZXH20090
3195-X1		Z3200, ZH3200
3197-X1		Z4200, ZH4200, Z4500
3194-X1	Rebuild Kit* - LPG/NH <sub>3</sub> Includes seals, blades, blade drivers, sideplates, cams, bearings, and gaskets.	Z2000, ZH2000, ZX2000, ZXH20090
3196-X1		Z3200, ZH3200
3198-X1		Z4200, ZH4200, Z4500
4915-X1	Adjustable bearing cap	522, 1022

PART NUMBER	INLET	OUTLET	AUXILLARY INLET	INTERNAL RELIEF VALVE
Z2000	2" NPT	2" NPT	None	150 psi
ZX2000	2" NPT	2" NPT	None	175 psi
Z3200	3" ANSI 300 lb.	2" EII	2" NPT	150 psi
Z4200	4" ANSI 300 lb.	Dual 2" NPT	2" NPT	150 psi

### Accessory Options – Hydraulic Drive Adaptor Kits

PART NUMBER	DESCRIPTION	MODEL REFERENCE
4496-X1	Hydraulic drive adapter option***	Z2000, ZX2000, Z3200
4496-1X1		Z4200

## Models Z/ZH3200 – Parts Details

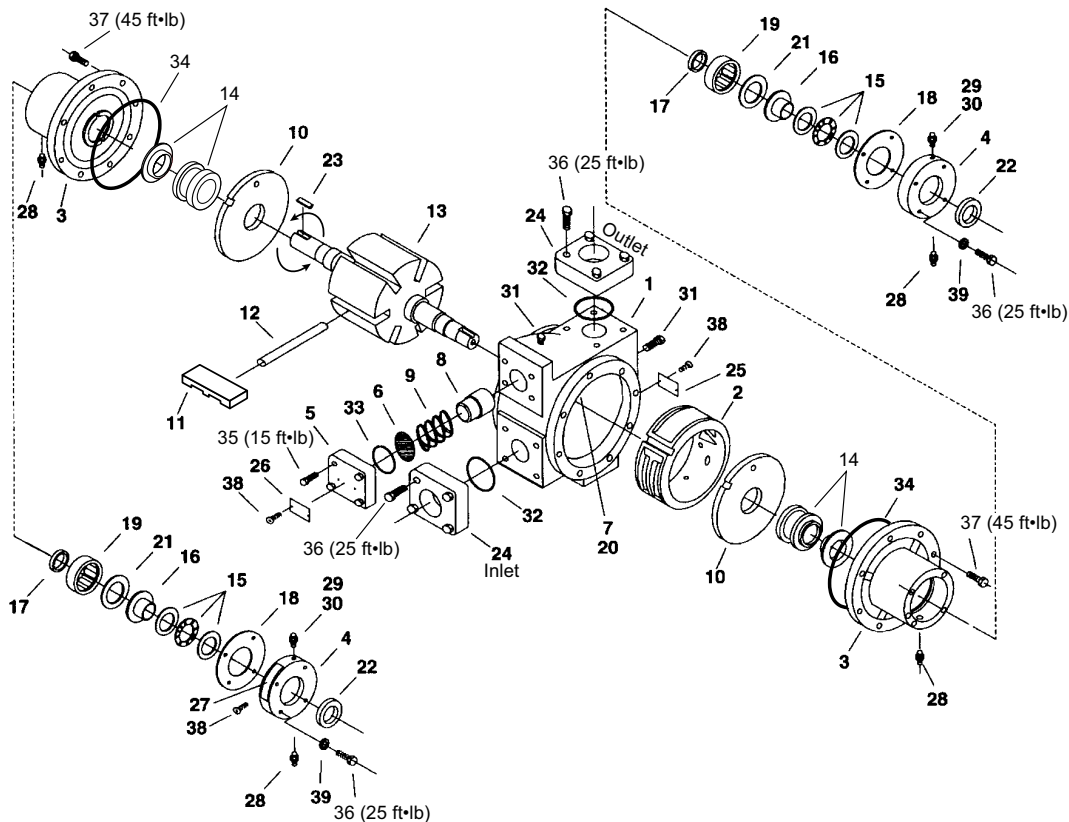

REF NO.	PART NO.	DESCRIPTION	QTY	REF NO.	PART NO.	DESCRIPTION	QTY
1	4413	Case	1	20	3253	Cam key pin	2
2	4414	Cam	1	21	2760-244	Retainer ring	2
3	4416	Head	2	22	4441	Grease seal	2
4	4417	Bearing cap	2	23	2270	Shaft keyz—1/4" x 1-9/16"	2
5	1174-3	Relief valve cap	1	24	4479-2	Flange—2"NPT	2
6	4282	Shim (Z2000, ZH2000)	1		4479-2S	Flange—2" welded	
		Shim (ZX2000, ZXH2000)	3	25	2649	Nameplate	1
7	4424	Cam key	1	26	4248	Relief valve nameplate	1
8	4425	Relief valve	1		4248-1	Relief valve nameplate (ZX2000, ZXH2000)	1
9	4426	Relief valve spring (Z2000, ZH2000)	1				
	1240	Relief valve spring (ZX2000, ZXH2000)	1	27	1359	Lubrication instruction plate	2
10	4427	Sideplate	2	28	1343	1/8" NPT relief fitting	4
11	4428	Vane <sup>2</sup>	6	29	2158	1/8" NPT grease zerk	2
12	4262-X	Vane driver	3	30	2159	Lubricap	2
13	4430-X2R	Rotor—shaft assembly	1	31	3442	1/4" NPT pipe plug	2
14	4431-X2R	Mechanical seal assembly	2	32	2-231_	O-ring—flange	2
15	4432	Thrust bearing assembly	2	33	2-224_	O-ring—relief valve cap	1
16	4435	Bearing race mounting ring	2	34	2-261	O-ring—case	2
17	4438	Grease seal	2	35	7001-031-NC125A	Bolt—hexagon head	4
18	4439	Bearing cap shim (.002) red	As req.	36	7001-037-NC150A	Bolt—hexagon head	16
	4439-1	Bearing cap shim (.010) brown		37	7001-043-NC125A	Bolt—hexagon head	16
	4439-2	Bearing cap shim (.020) yellow		38	7012-006-SF025E	Screw	8
19	2754-X	Bearing	2	39	7206-037A	Lockwasher	8



**Models Z/ZH3500 – Parts Details**

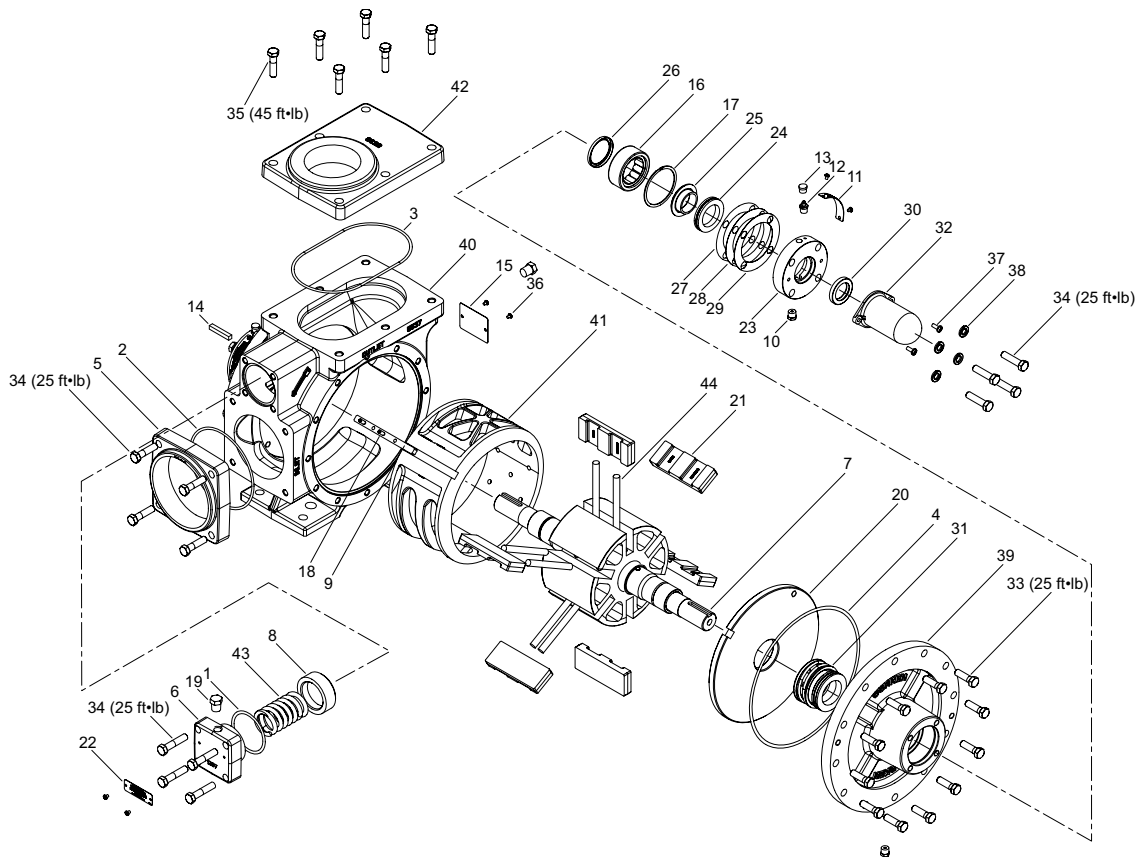

REF NO.	PART NO.	DESCRIPTION	QTY	REF NO.	PART NO.	DESCRIPTION	QTY
1	2-228	O-ring	1	22	4248	Relief valve warning tag	2
2	2-245	O-ring	1	23	4417	Bearing cap	2
3	2-259	O-ring	1	24	4432	Thrust bearing assembly	2
4	2-268	O-ring	2	25	4435	Thrust bearing mounting ring	2
5	1206-3	Inlet flange—3" NPT	1	26	4438	Grease seal / Oil seal	2
	1206-4	Inlet flange—4" NPT	1	27	4439	Bearing cap shim—0.002"	2
	1206-3S	Inlet flange—3" WF	1	28	4439-1	Bearing cap shim—0.010"	2
	1206-4	Inlet flange—4" WF	1	29	4439-2	Bearing cap shim—0.020"	2
6	1207-2	Relief valve cap	1	30	4441	Grease seal	2
7	1208-1X6R	Rotor shaft assembly	1	31	4431-X2	Mechanical seal assembly	2
8	1224	Relief valve	1	32	4985	Coro-Vane shaft cover	1
9	1309	Cam key	1	33	7001-037NC125A	Hex head bolt	24
10	1343	Grease relief fitting	4	34	7001-037NC150A	Hex head bolt	16
11	1359	Lubrication plate	2	35	7001-043NC150A	Hex head bolt	64
12	2158	Grease zerk	2	36	7012-006SF019E	Screw	9
13	2159	Lubricap	2	37	7012-010SF050E	Screw	2
14	2270	Shaft key—1/4"	1	38	7206-037A	Lock washer—0.375"	8
15	2649	Nameplate	1	39	5534	Head	2
16	2754	Outer bearing	2	40	5537	Case	1
17	2760-244	Retainer ring	2	41	5539	Cam	1
18	3253	Cam key pin	2	42	5538	Outlet flange—3" NPT Elongated	1
19	3442	Pipe plug—1/4" NPT	2		5538-3S	Outlet flange—3" WF Elongated	1
20	3935	Sideplate	2	43	5548	Spring	1
21	3936	Vane <sup>3</sup>	6	44	5554-X	Vane driver	6

PUMPS, MOTORS & BYPASS VALVES

## Models Z/ZH4200 – Parts Details

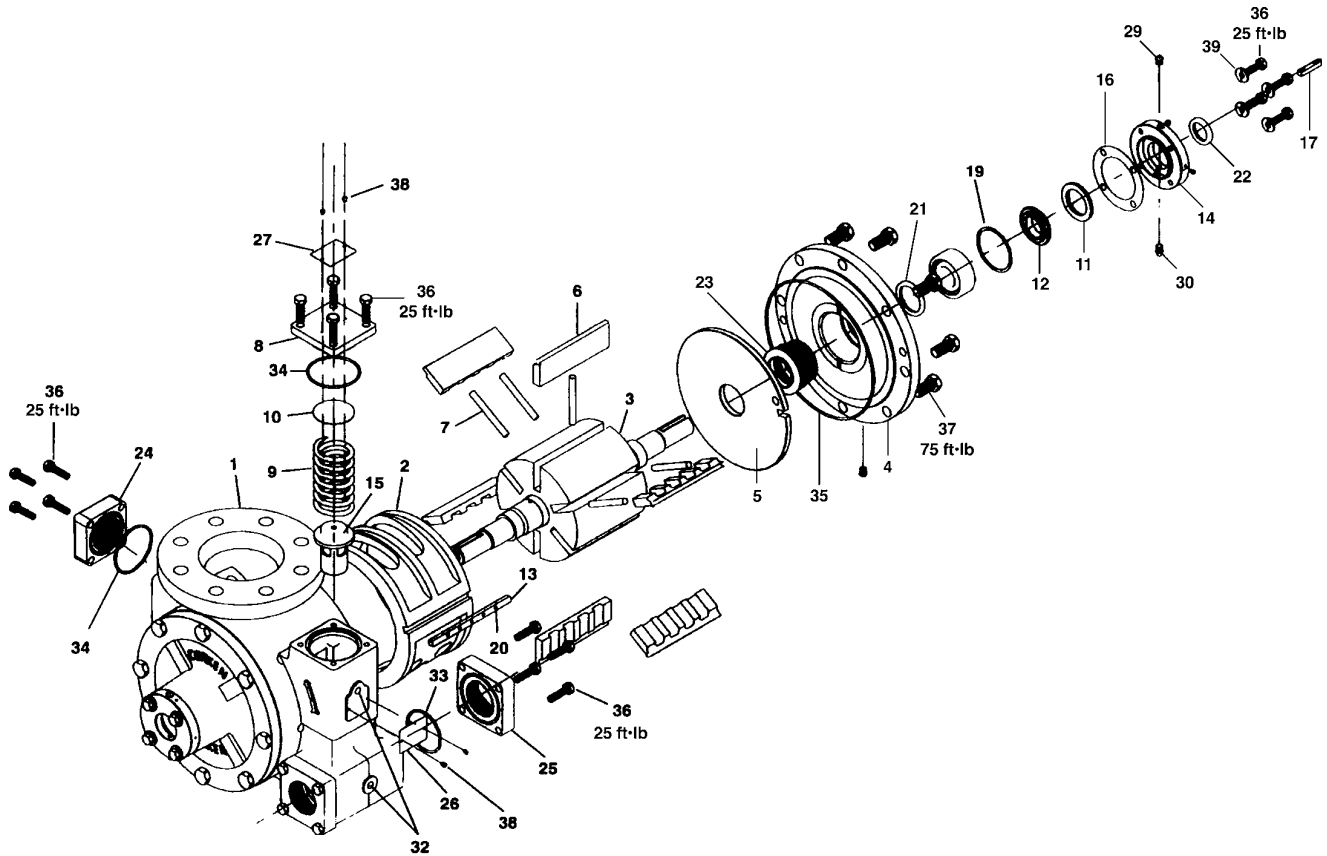

REF NO.	PART NO.	DESCRIPTION	QTY	REF NO.	PART NO.	DESCRIPTION	QTY
1	4442	Case	1	22	4463	Grease Seal	2
2	4443	CAM	1	23	4464-X_2	Mechanical Seal Assembly	2
3	4444-X2R	Rotor-Shaft Assembly	1	24	1172-2	AUX. Inlet Flange—2" NPT	1
4	4445	Head	2		1172-2S	AUX. Inlet Flange—2" WF	1
5	4446	Sideplate	2		1920-3	AUX. Inlet Flange—blind	1
6	4448	Vane	6	25	4479-2S	Discharge flange—2" WF	2
7	4449-X	Vane Driver	5		4981-2	Discharge flange—2" NPT	
8	4450	Relief Valve Cap	1	26	2649	Nameplate	1
9	4451	Relief Valve Spring	1	27	4248	Relief Valve Nameplate	1
10	4452	Shim	1	28	1359	Lubrication Instruction Plate	2
11	4453	Thrust Bearing Assembly	2	29	1343	1/8 NPT Relief Fitting	4
12	4454	Bearing Race Mounting Ring	2	30	2158	1/8 NPT Grease Zerk	2
13	4455	CAM Key	1	31	2159	Lubricap <sup>2</sup>	2
14	4456	Bearing Cap	2	31	2159	Lubricap <sup>2</sup>	2
15	4457	Relief Valve	1	32	3442	1/4 NPT Pipe Plug	2
	4458	Bearing Cap Shim (.002) red		33	2-231_	O-Ring Discharge Flange	2
16	4458-1	Bearing Cap Shim (.010) brown	As req.	34	2-234_	O-Ring Aux. Inlet Flange	1
	4458-2	Bearing Cap Shim (.020) yellow		35	2-270_	O-Ring- Case <sup>2</sup>	2
17	4459	Shaft Key -5/16 x 1 3/4	1	36	7001-037NC150A	Bolt - Hexagon Head	24
18	4460-X	Roller Bearing	2	37	7001-062NC125A	Bolt - Hexagon Head	16
19	2760-283	Retainer Ring	2	38	7012-006SF019E	Screw	8
20	3253	CAM Key Pin	5	39	7206-037A	Lockwasher	8
21	4462	Grease Seal	2				

**Models Z/ZH4500 – Parts Details**

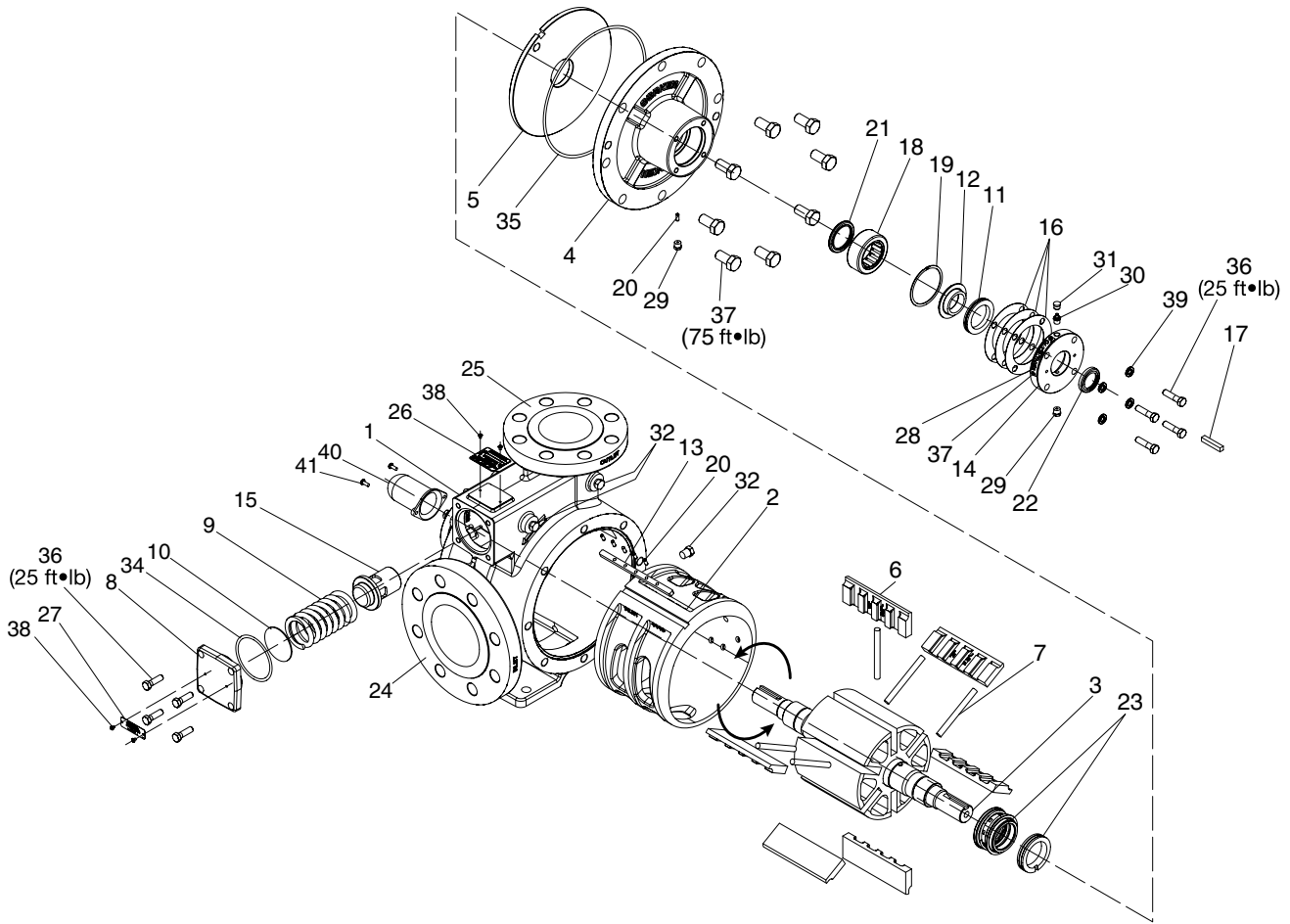

REF NO.	PART NO.	DESCRIPTION	QTY	REF NO.	PART NO.	DESCRIPTION	QTY
1	5522	Case	1	21	4462	Grease seal	2
2	4443	Cam	1	22	4463	Grease seal	2
3	4444-X2R	Rotor-shaft assembly	1	23	4464-X_2	Mechanical seal assembly2	2
4	4445	Head	2	24	---	Inlet flange—4" ANSI	1
5	4446	Sideplate	2	25	---	Outlet flange—3" ANSI	2
6	4448	Vane	6	26	2649	Nameplate	1
7	4449-X	Vane driver	5	27	4248	Relief valve nameplate	1
8	4450	Relief valve cap	1	28	1359	Lubrication instruction plate	2
9	4451	Relief valve spring	1	29	1343	1/8 NPT relief fitting	4
10	4452	Shim	1	30	2158	1/8 NPT grease zerk	2
11	4453	Thrust bearing assembly	2	31	2159	Lubricap	2
12	4454	Bearing race mounting ring	2	32	3442	1/4 NPT pipe plug	2
13	4455	Cam key	1	33	2-231_	O-ring—discharge flange	2
14	4456	Bearing cap	2	34	2-234_	O-ring—auxiliary inlet flange	1
15	4457	Relief valve	1	35	2-270_	O-ring—case	2
16	4458	Bearing cap shim (.002) red	As req.	36	7001-037NC150A	Bolt—hexagon head	24
	4458-1	Bearing cap shim (.010) brown		37	7001-062NC125A	Bolt—hexagon head	16
	4458-2	Bearing cap shim (.020) yellow		38	7012-006SF019E	Screw	8
17	4459	Shaft key—5/16 x 1-3/4	1	39	7206-037A	Lockwasher	8
18	4460-X	Roller bearing	2	40	4985	Shaft cover	1
19	2760-283	Retainer ring	2	41	7012-010SF050E	Screw	2
20	3253	Cam key pin	5				

## Small Capacity Stationary

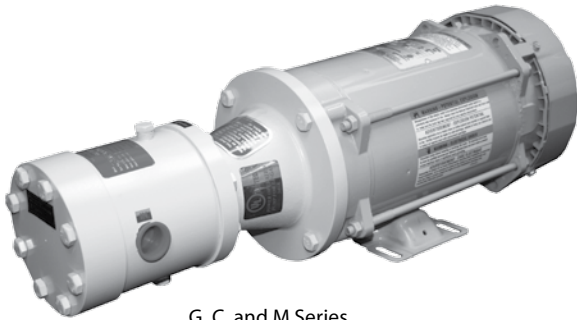

G, C, and M Series

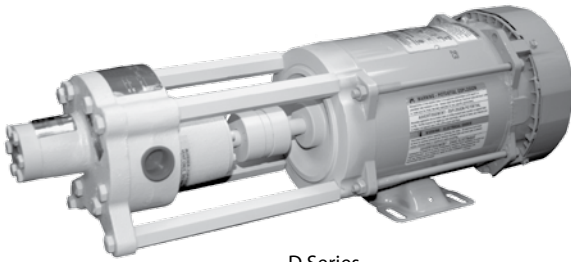

D Series

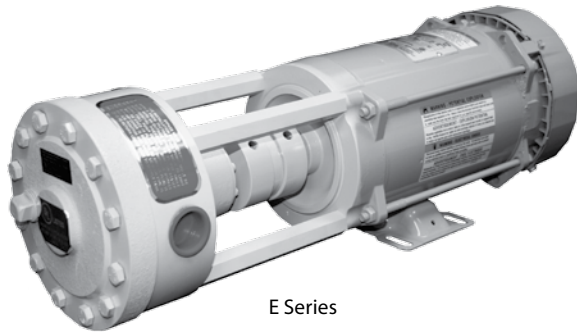

E Series

PART NUMBER	DESCRIPTION	MOTOR	VOLT	WORKS WITH
MC-1Z	Pump only	-	-	-
MC1-M5B	Pump with Motor	1 1/2 HP	115/208/230	-
GC-1	Pump Only	-	-	-
GC-1LZ-EM1-3B	3/4" Pump with Superseal	1 HP	115/208/230	-
GC-1LZ-EM-6B	3/4" Pump with Superseal	1 1/2 HP	-	-
GC-1LZ-M	Pump with Motor	1 1/2 HP	115/208/230	-
EG-1Z	Pump only	-	-	-
EG-1Z-M	Pump with Motor	1 HP	-	-
E-100ZX	Exchange, Shaft-Seal Assembly	-	-	EG-1
E-100HZX	Exchange, Shaft-Seal Assembly	-	-	EC-H
DW-1Z	Pump only	-	-	-
DW-1Z-M	Pump with Motor	1 HP	115/208/230	-
DW-HZ	Pump only	-	-	-
DW-HZ-M	Pump with Motor	1 1/2 HP	115/208/230	-

MODEL	MOTOR SPEED	AVERAGE DELIVERY RATE, 3600 RPM		INTERNAL BYPASS RELIEF SETTINGS	MAX. DIFFERENTIAL PRESSURE	INLET/OUTLET SIZE	MOTOR	PUMP ROTATION
		40 PSID	75 PSID					
GC-1*	3600 RPM	9 GPM	8 GPM	GC-1-90 psi MC-1 Adjustable	125 psi	3/4" FNPT	1 HP	GC-1-CW MC-1-CCW
MC-1*	3600 RPM	9 GPM	8 GPM	GC-1-90 psi MC-1 Adjustable	125 psi	3/4" FNPT	1 HP	GC-1-CW MC-1-CCW
GC-1LZ*	3600 RPM	11 GPM	9 GPM	150 psi	125 psi	3/4" FNPT	1 1/2 HP	CW
EG-1	3600 RPM	8 1/2 GPM	7 GPM	90 psi	125 psi	3/4" FNPT	1 HP	CW
ECH-1	3600 RPM	13 1/2 GPM	12 GPM	90 psi	125 psi	1" FNPT	1 1/2 HP	CW
DW-1	3600 RPM	8 1/2 GPM	7 GPM	90 psi	125 psi	3/4" FNPT	1 HP	CCW
DW-H	3600 RPM	13 1/2 GPM	12 GPM	90 psi	125 psi	1" FNPT	1 1/2 HP	CCW

\*External bypass valve required with GC-1, MC-1, GC-1LZ

### Small Capacity Stationary – GC and MC Series Parts Detail

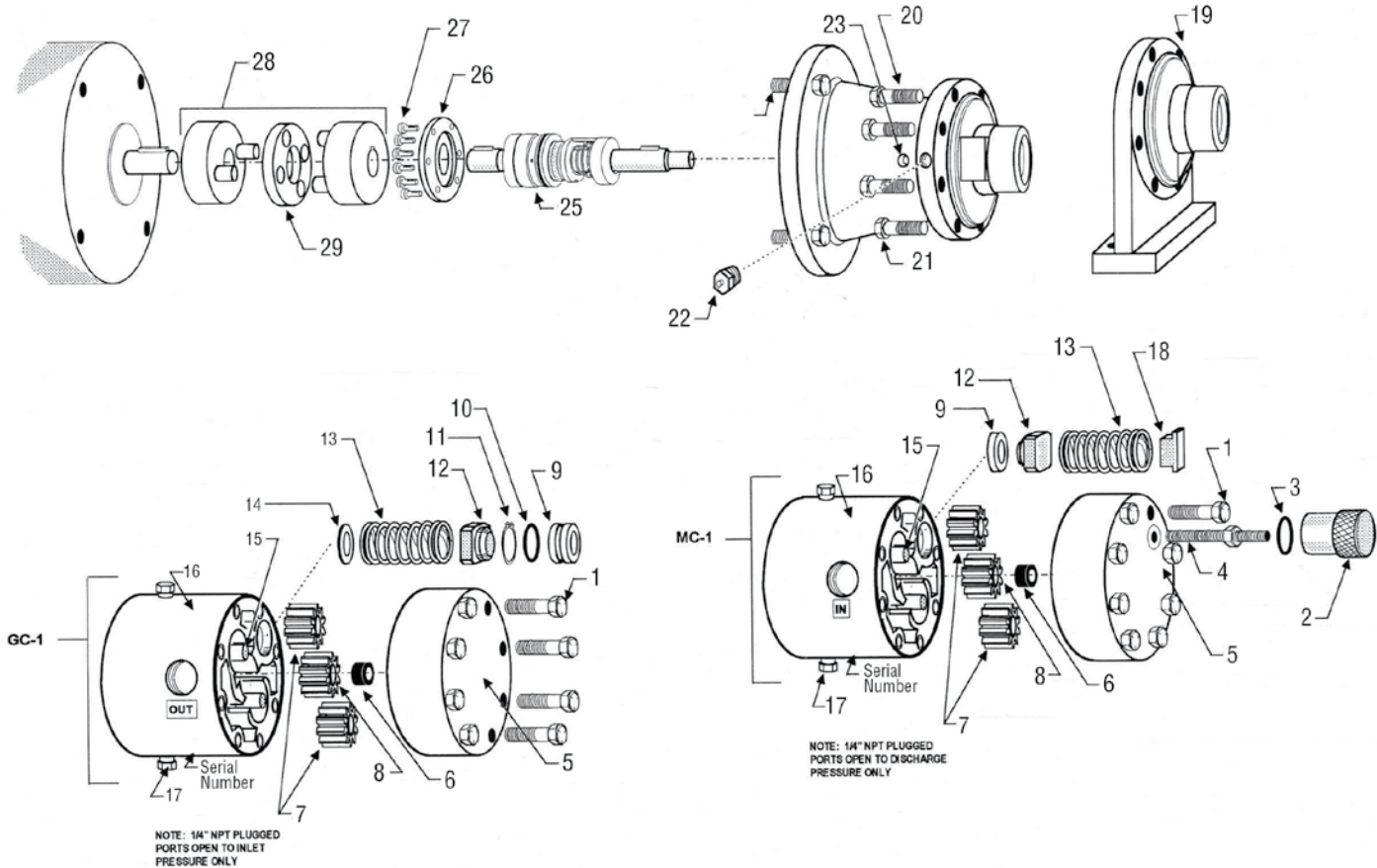

REF. NO.	PART NUMBER	DESCRIPTION	QTY	REF. NO.	PART NUMBER	DESCRIPTION	QTY
1	3/8-16Tx1-3/4L	Cap screws for gear end cover	8	17	14PLUG	1/4" Pipe plugs	2
2	649-30	Valve cap	1	18	649-40	Bypass valve spring retainer	1
3	6227-12	O-ring	1	19	649-3D**	Foot mount shaft end cover (optional)	1
4	649-42	Valve adjusting screw with nut	1	20	649-3C	Flanged shaft end cover mounts directly to fractional hp, NEMA C-face motor	1
5	649-42	Gear end cover for MC-1	11	21	3/8-16Tx1-1/4L	Cap screws	8
5	649-2G	Gear end cover for GC-1		22	FITTING1827**	Optional leak detect port bleed fitting	1
6	649-11	Main shaft bushing for cover	1	23		5/16" access port for coupling set screw	1
7	649-6	Idler gears with bushing	2	24	3/8-16Tx1-1L	Cap screws for motor mounting	4
8	649-5	Drive gear	1	25	MC1-100	Shaft-seal assembly for GC-1 and MC-1	1
9	649-29S	Bypass valve seat, MC-1	1	26	649-15	Bearin retainer plate	1
9	649-29	Bypass valve seat, GC-1		27	10-32Tx1/2L	Fillister head screws for bearing retainer plate	6
10	6227-14	O-ring for valve seat	1	28	VC-20	Complete drive coupling, 5/8" x 5/8"	1
11	5008-100	Lock ring	1	29	FD-20	Coupling insert	1
12	649-41	Bypass valve	1		FD-20T**	---	-
13	649-31	Bypass valve spring	1				
14	649-29A**	Bypass valve spring spacer (optional)	1				
15	649-9	Idler gear shafts	2				
16	649-1	Main Housing	1				

\*\*Parts or model types for special or heavy duty applications

## Small Capacity Stationary – D Series Parts Detail

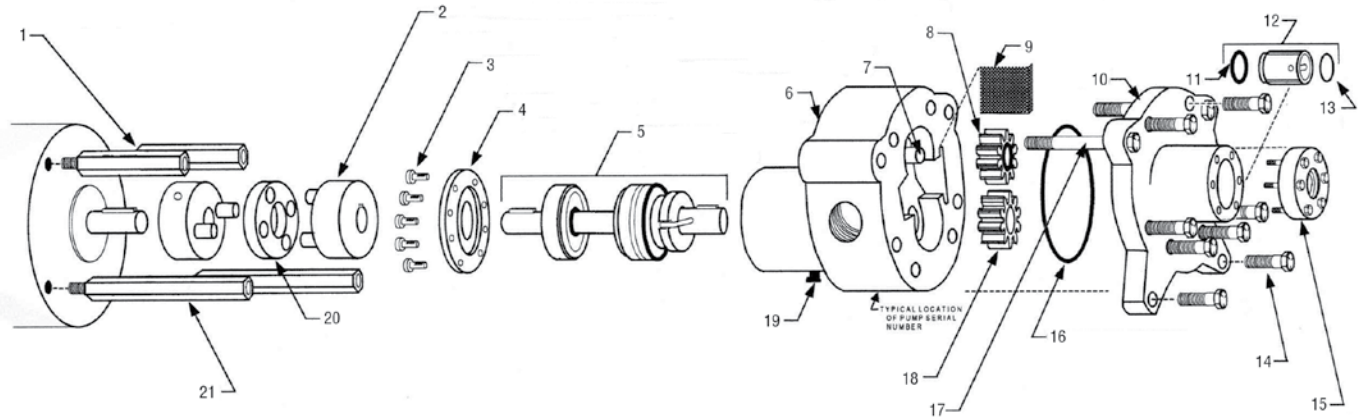

REF. NO.	PART NUMBER	DESCRIPTION	QTY	REF. NO.	PART NUMBER	DESCRIPTION	QTY
1	D-3S	Mounting Spacers (Short) with studs	2	12	E-20ASSY	Bypass valve cartridge (includes o-rings)	1
2	VC-20	Complete drive coupling (electric motor use)	1	13	568-118	Top o-ring	1
3	10-32Tx1/2L	Fillister head screws for bearing retainer plate	8	14	3/8-16Tx1-1/4L	Short GR.5 cap screws	8
4	E-15	Bearing retainer plate	1	15	D-3	Bypass flange with 1/2" NPT outlet	1
5	E-100Z	Shaft - Seal assembly for DW-1Z	1		1/4-20Tx1-1/4L	Small GR.5 cap screws	6
	E-100HZ	Shaft - Seal assembly for DW-HZ		16	6230-14	O-ring for gear end cover	1
6	D-1	Main Housing for DW-1Z	1	17	3/8-16Tx3-1/4L	Long GR.5 cap screws for mounting to spacers	2
	D-1H	Main Housing for DW-HZ		18	EG-5	Drive gear for DW-1Z	1
7	E-9	Idler Gear Shaft	1		EC-5H	Drive gear for DW-HZ	1
8	EG-6	Idler Gear w/ E-10 brushing for DW-1Z	1	19	105CUP	Leak detection port with bleeder cup	1
	EC-6H	Idler Gear w/ E-10 brushing for DW-HZ		20	FD-20	Coupling insert	1
9	D-21	Strainer screen	1	21	D-3L	Mounting spacers (long) with studs for DW-1Z	2
10	D-2	Gear end cover	1		D-3LH	Mounting spacers (long) with studs for DW-HZ	2
11	6227-17	Bottom o-ring	1				

### Small Capacity Stationary – E Series Parts Detail

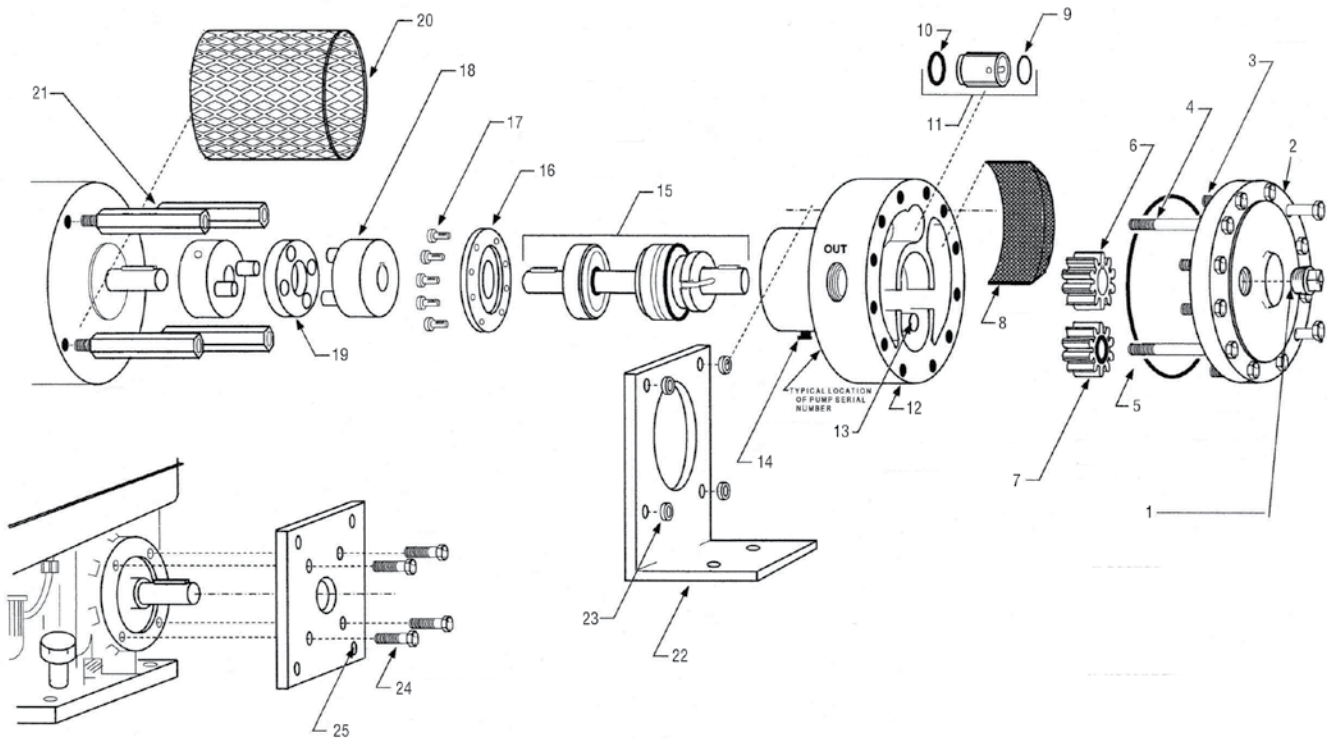

REF. NO.	PART NUMBER	DESCRIPTION	QTY	REF. NO.	PART NUMBER	DESCRIPTION	QTY
1	12 PLUG	3/4" NPT square head steel pipe plug for EG-1*	1	15	E-100	Shaft Seal Assembly for EG-1	1
	34 PLUG	3/4" NPT square head steel pipe plug for EC-H*	1	E100[H]	Shaft Seal Assembly for EC-H	1	
2	E-2	Gear end cover	1	16	E-15	Bearing Retainer Plate	1
3	3/8-16Tx1-1/2L	Short GR.5 cap screws for gear and cover	8	17	10-32Tx1/2L	Fillister Head Screws for Bearing Retainer Plate	8
4	3/8-16Tx3-1/2L	Long GR.5 cap screws for mounting to spacers	4	18	VC-20	Complete Drive Coupling (electric motor use) EG-1**	1
5	6230-28	O-ring for gear end cover	1		VC-30	Complete Drive Coupling (electric motor use) EC-H**	1
6	EG-5	Drive gear for EG-1	1	19	FD-20	Coupling Insert for EG-1	1
	EC-5H	Drive gear for EC-H	1		FD-30	Coupling Insert for EC-H	1
7	EG-6	Idler Gear w/ E-10 brushing for EG-1	1	20	CG-E	Optional-Coupling Guard Screen	1
	EC-6H	Idler Gear w/ E-10 brushing for EC-H	1	21	E-3	Mounting Spacers with Studs	4
8	EC-21	Strainer screen	1	22	E-52	Optional - Foot Mounting Bracket	1
9	568-118	Top O-ring	1	23	R3-21	Spacers for Optional Foot Mount Bracket	4
10	6227-17	Bottom o-ring	1	24	5/16-24Tx1L	Gr.5 Cap Screws for Mounting Spacers (see 21)	4
11	E-20ASSY	Bypass valve cartridge (includes o-rings)	1				
12	E-1	Main housing for EG-1	1	25	---	Threaded Holes for E-3 Mounting Spacers (see 21)	4
	E-1H	Main housing for EC-H	1				
13	E-9	Idler Gear Shaft	1	26	E-51	Engine Adapter Plate	1
14	105CUP	Leak detection port with bleeder cup	1				

## Medium Capacity Stationary – Small Bulk Plant Installations

### Shaft Seal Assembly

PART NO.	WORKS FOR
MC-101	MC-1044
	MC-1044H
MC-102	MC-2

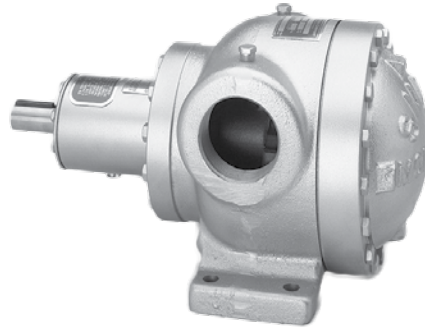

MC-2

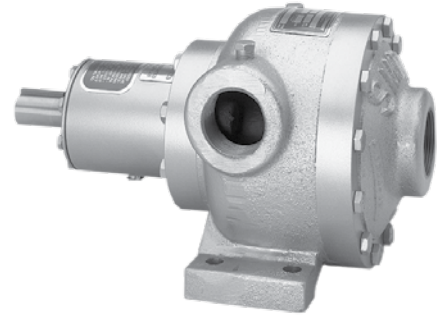

MC-1044

### Parts

MODEL	DESCRIPTION	AVERAGE DELIVERY RATE, 1800 RPM		MAX. DIFFERENTIAL PRESSURE	INLET/OUTLET SIZE	MOTOR	PUMP ROTATION
		40 PSID	75 PSID				
MC-1044	Pump	17 GPM	14 GPM	125 psi	1½" FNPT	1½ HP to 40 psid, 2 HP over 75 psid	Reversible
MC-1044H	Pump	30 GPM	25 GPM	125 psi	1½" FNPT	2 HP to 40 psid, 3 HP over 75 psid	Reversible
MC-2	Pump	42 GPM	35 GPM	125 psi	2½" FNPT	3 HP to 40 psid, 5 HP over 75 psid	Reversible

## Large Capacity Stationary – Heavy Duty

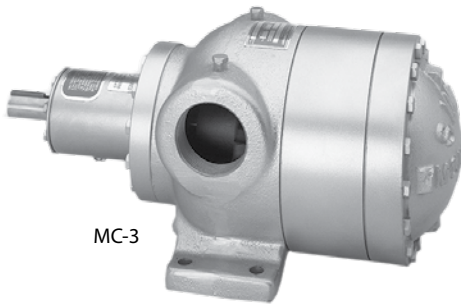

MC-3



MC-4

### Shaft Seal Assembly

PART NO.	WORKS FOR
MC-103	MC-3
MC-104	MC-4
MC-105	MC-5

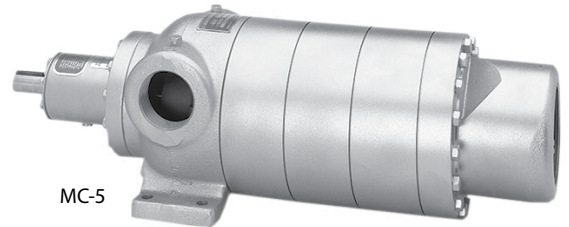

MC-5

### Parts

MODEL	DESCRIPTION	AVERAGE DELIVERY RATE, 1800 RPM		MAX. DIFFERENTIAL PRESSURE	INLET/OUTLET SIZE	MOTOR	PUMP ROTATION
		40 PSID	75 PSID				
MC-3	Pump	84 GPM	70 GPM	125 psi	2 1/2" FNPT	5 HP TO 40 PSID, 7 1/2 HP OVER 75 PSID	Reversible
MC-4	Pump	125 GPM	105 GPM	125 psi	4" FNPT inlet, 2 1/2" FNTP Outlet	7 1/2 HP TO 40 PSID, 10 HP OVER 75 PSID	CCW
MC-5	Pump	167 GPM	142 GPM	125 psi	4" FNPT inlet, 2 1/2" FNTP Outlet	10 HP TO 40 PSID, 15 HP OVER 75 PSID	CCW



## Truck Pumps – Foot Mounts

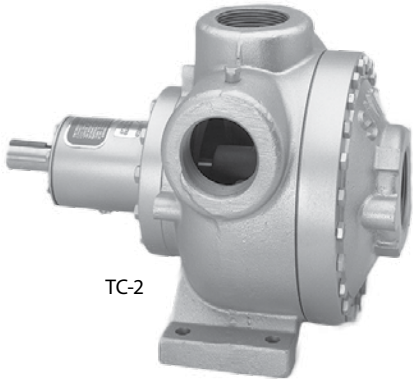

TC-2

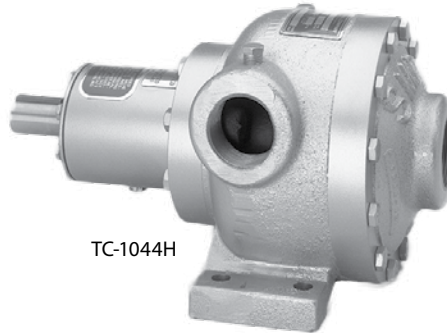

TC-1044H

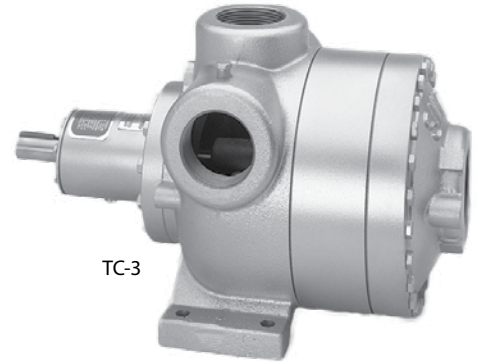

TC-3

### Parts

MODEL	DESCRIPTION	AVERAGE DELIVERY RATE, 1800 RPM		MAX. DIFFERENTIAL PRESSURE	INLET/OUTLET SIZE	MOTOR	PUMP ROTATION
		40 PSID	75 PSID				
TC-1044H	Pump	30 GPM @ 900 RPM	25 GPM @ 900 RPM	125 psi	1½" FNPT	50 lbs.	Reversible
TC-2	Pump	42 GPM @ 500 RPM	35 GPM @ 500 RPM	125 psi	2½" FNPT	100 lbs.	Reversible
TC-3	Pump	86 GPM @ 500 RPM	70 GPM @ 500 RPM	125 psi	2½" FNPT	135 lbs.	Reversible

### Shaft Seal Assembly

PART NO.	WORKS FOR
MC-101	TC-1044H
MC-102	TC-2
MC-103	TC-3

## Truck Pumps – Flange Mount

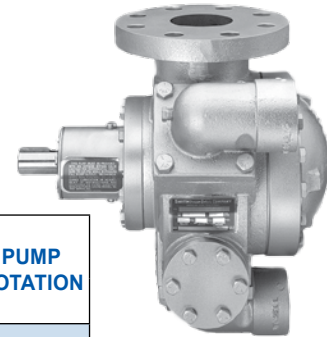

MODEL	DESCRIPTION	AVERAGE DELIVERY RATE, 1800 RPM		MAX. DIFFERENTIAL PRESSURE	INLET/OUTLET SIZE	MOTOR	PUMP ROTATION
		40 PSID	75 PSID				
MCAT-2L	Pump	39 GPM @ 700 RPM	35 GPM @ 700 RPM	125 psi	2" FNPT threaded, 90° elbow	108 lbs.	Left
MCAT-2R	Pump	39 GPM @ 700 RPM	35 GPM @ 700 RPM	125 psi	2" FNPT threaded, 90° elbow	108 lbs.	Right
MCAT-3L	Pump	78 GPM @ 700 RPM	70 GPM @ 700 RPM	125 psi	2" FNPT threaded, 90° elbow	137 lbs.	Left
MCAT-3R	Pump	78 GPM @ 700 RPM	70 GPM @ 700 RPM	125 psi	2" FNPT threaded, 90° elbow	137 lbs.	Right

## Coro-Flo Pumps (Models 060 & 075 AutoGas)

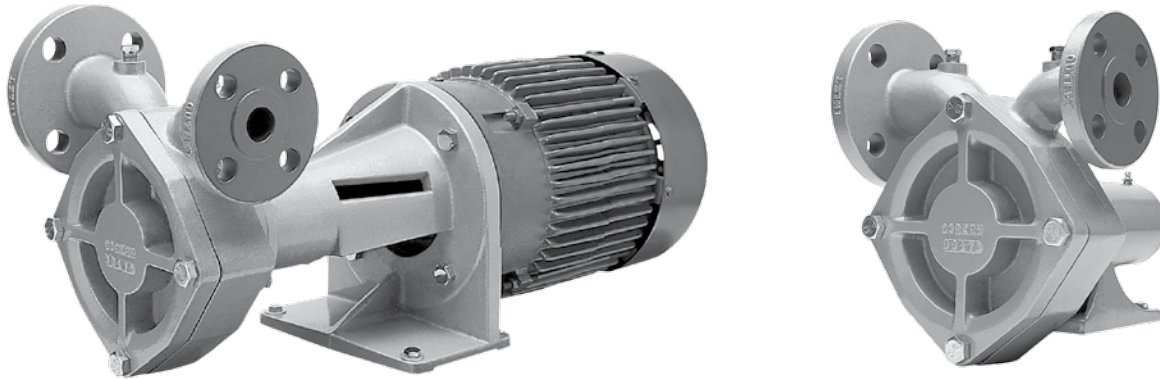

PART NUMBER	DESCRIPTION	INLET	OUTLET	MOUNTING OPTIONS		
				PART NUMBER	DESCRIPTION	MAXIMUM MOTOR FRAME SIZE
FF060	Frame mounted ANSI flange	1 1/2" ANSI*	1" ANSI*	101-14	Mounting set-up for direct drive. Includes steel baseplate, flexible coupling, and coupling guard. (pump and motor not included)	184T, 215T, 256T
FF075						
FD060	Frame mounted DIN flange	40 mm PN40 DIN 2635	25 mm PN40 DIN 2635			
FD075						
DLF060**	Direct mount pump with C-Face frame ANSI flange	1 1/2" ANSI*	1" ANSI*			
DLF075**						
DLD060**	Direct mount pump with C-Face frame DIN flange	40 mm PN40 DIN 2635	25 mm PN40 DIN 2635			
DLD075**						

\*All standard ANSI port sizes are 300 lbs.

\*\*Accommodates NEMA motors up to and including 10 hp (215 TC frame size).

PART NUMBER	DESCRIPTION	MODEL REFERENCE
<b>SINGLE PHASE APPLICATIONS</b>		
HDPFF060-1P53	Pump, 101 mounting, B166B-1CAU, 5 hp Exp. 60Hz 3 ph motor and Variable frequency drive	FF060CD6A
HDPDLF060-1P53	Pump, coupling, B166B-1CAU and 5 hp Exp. 60 Hz 3 ph C-face motor and Variable frequency drive	DLF060CD6A
HDPFF060-1P51	Pump, 101 mounting, B166B-1CAU and 5 hp Exp. 60Hz 1 ph motor	FF060CD6A
HDPDLF060-1P51	Pump, coupling, B166B-1CAU and 5 hp Exp. 60 Hz 1 ph C-face motor	DLF060CD6A
HDPFF075-1P75	Pump, 101 mounting, B166B-1CAU, 7.5 hp Exp. 60Hz motor and Variable frequency drive	FF075CD6A
HDPDLF075-1P75	Pump, coupling, B166B-1CAU and 7.5 hp Exp. 60 Hz C-face motor and Variable frequency drive	DLF075CD6A
<b>THREE PHASE APPLICATIONS</b>		
HDPFF060-3P53	Pump, 101 mounting, B166B-1CAU and 5 hp Exp. 60Hz 3 ph motor	FF060CD6A
HDPDLF060-3P53	Pump, coupling, B166B-1CAU and 5 hp Exp. 60 Hz 3 ph C-face motor	DLF060CD6A
HDPFF075-3P75	Pump, 101 mounting, B166B-1CAU, 7.5 hp Exp. 60Hz motor	FF075CD6A
DLF075CD6A	Pump, coupling, B166B-1CAU and 7.5 hp Exp. 60 Hz C-face motor	DLF075CD6A

### Part Options

PART NUMBER	DESCRIPTION	WORKS FOR
6133-X1	Companion Flange Kit (FF/DLF)	
1345-2	Coupling (182/184 TC NEMA frame size)	DLF060/DLF075
1345-1	Coupling (213/215 TC NEMA frame size)	DLF060/DLF075
1345	Special bore coupling (all other NEMA and IEC size C-face motors)	DLF/DLD060/DLD075

**Bypass Valves**



B166



B177



T166

PART NUMBER	INLET	OUTLET	SLIP-ON WELD FLANGE	DIFF. PRESSURE RANGE PSI (BAR)	O-RING MATERIAL OPTIONS
B166	3/4", 1"	3/4", 1"	No	25-225 (1.7 - 15.5)	Buna-N (standard), Neoprene, PTFE, Viton, ethylene-propylene
T166	1 1/4", 1 1/2"	1 1/4", 1 1/2"	No	25-225 (1.7 - 15.5)	
B177	1 1/4", 1 1/2", 2", 2 1/2"	1 1/4", 1 1/2", 2", 2 1/2"	2", 2 1/2"	20-160 (.7 - 11)	



PART NUMBER	SIZE	FLOW (GPM)
WW-120	1/2" x 1/2"	5 - 10
WW-340	3/4" x 3/4"	10-15
WW-100	1" x 1"	20-35
WW-114	1 1/4" x 1 1/4"	35-50
WW-112	1 1/2" x 1 1/2"	50-100
WW-200	2" x 2"	100-150
WW-212	2 1/2" x 2 1/2"	150-250

PART NUMBER	SIZE	PUMP SIZE	PRESSURE SETTING	ADJUST. RANGE	CAP.
BV-3/4	3/4"	1 1/4" - 1 11/2"	95 psi	70-100 psi	50 GPM
BV-1	1"	1 1/4" - 1 11/2"	95 psi	70-100 psi	50 GPM
BV-1 1/4	1 1/4"	1 1/2" - 2"	95 psi	70-100 psi	125 GPM
BV-1 1/2	1 1/2"	2" - 3"	95 psi	70-100 psi	125 GPM
BV-2-95	3"-4"	3" - 4"	95 psi	90-125 psi	225 GPM



## Blackmer Pumps and Kits

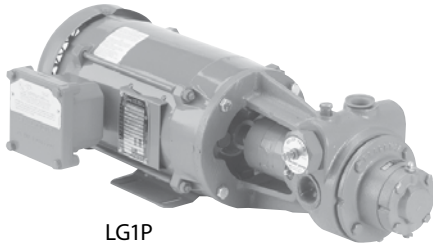

LG1P



TLGF3

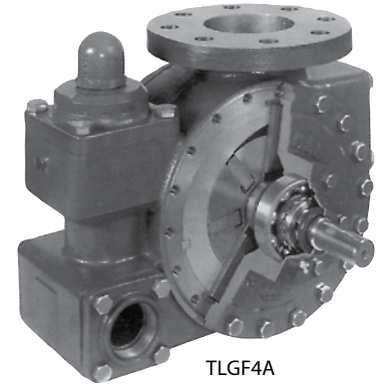

TLGF4A

### Cylinder and Motor Fueling Pump

PART NUMBER	CAPACITY GPM PROPANE	INLET / OUTLET	MOTOR HP	MOTOR MOUNTING
LGF1	8	1"	1	C-Face
LGF1P	13	1"	1 1/2	C-Face
LGRLF1.25	16	1 1/4"	1 1/2	C-Face
LGLF1.25	21	1 1/4"	1 1/2	C-Face
LGL1.25	21	1 1/4"	1 1/2	Foot
LGL1.5	33	1 1/2"	3	Foot

### Stationary Pumps

PART NUMBER	CAPACITY GPM PROPANE	INLET / OUTLET	MOTOR HP	MOTOR MOUNTING
LGLD2E	67	2" NPT	2" NPT	5
LGLD3E	133	3" NPT	3" NPT	10
LGLD4	270	4" Flange	3" Flange	20

### Truck Pumps

PART NUMBER	CAPACITY GPM PROPANE	INLET / OUTLET	MOTOR HP	MOTOR MOUNTING
TLGLF3	93	3" Flange	2" NPT	2" NPT
TLGLF4	280	4" Flange	2" NPT	Dual 2" NPT

### Maintenance Kits

PART NUMBER	FOR PUMP
898994	LGF1E and PE - 4 Vane
898994	LGF1E and PE - 6 Vane
898917	LGRLG-1 1/4 - 4 Vane
898918	LGL-1 1/4 - 4 Vane
898919	LGL-1 1/2 - 4 Vane
898976	LGRLF-LGL 1 1/4 and LGL 1's - 8 Vane
898979	LGLD2E
898981	LGLD3E
898922	LGLD4
898980	TLGLF3C
898922	TLGLF4A
899224	TLGF4B

### Rebuild Kits

PART NUMBER	FOR PUMP
899076	LGRLG-1 1/4 - 4 Vane
899077	LGL-1 1/4 - 4 Vane
899078	LGL-1 1/2 - 4 Vane
899076	LGRLF- 1/4 - 8 Vane
899077	LGL-1 1/4 - 8 Vane
899078	LGL-1 1/2 - 8 Vane
899079	LGLD2E
889081	LGLD3E
899080	TLGLF3C
899022	TLGLF4A and LGLD-4
899124	TLGLF4B

**Repair Kits**

**-Pump Repair Kits**

PART NUMBER	MODEL NUMBERS	SEAL ASSEMBLY	BEARINGS	GREASE SEALS	GREASE SEAL	BLADES	SIDEPLATES	FLANGE GASKET	CASE O-RING
2904-X2	521E, 522E, T522E, TR522E	1769-XRA (2)	2754-X (2)	1358 (2)	2014	1168-7 (10)	1163-2 (2)	2010 (3)	2-261A (2)
3109-X1	T522G, TR522G	1769-XRA (2)	2754-X (2)	1358 (2)	2014	4000 (6)	3932 (2)	2010 (2)	2-261A (2)
2905-X5	T722G, TR722G	1769-XRA (2)	2754-X (2)	1358 (2)	2014	3981 (6)	3932 (2)	2010 (2)	2-261A (2)
2906-X2	1021E, 1022E, F1021E, F1022E	1769-XRA (2)	2754-X (2)	1358 (2)	2014	1308-9 (10)	1209-1 (2)	-	2-268A (2)
2907-X3	F1521F, F1522F, T1522F, TR1522F	1769-XRA (2)	2754 (2)	1358 (2)	2014	3477 (6)	3476 L/R (1/1)	-	2-268A (2)
3193-X1	Z2000	4431-XA2	2754-X (2)	4441 (2)	-	4428 (6)	4427 (2)	-	2-261A (2)
3195-X1	Z3200	4431-XA2	2754-X (2)	4441 (2)	-	4232 (6)	4231 (2)	-	2-261A (2)
3197-X1	Z4200	4464-XA2	4460-X (2)	4463 (2)	-	4448 (6)	4446 (2)	-	2-270A (2)

**Pump Repair Kits (continued)**

PART NUMBER	MODEL NUMBERS	FLANGE O-RING			R.V. O-RING			ROTOR AND SHAFT		CAM
		TYPE 1	TYPE 2	TYPE 3	TYPE 1	TYPE 2	TYPE 3	TYPE 1	TYPE 2	
2904-X2	521E, 522E, T522E, TR522E	2-234A (2)	-	-	2-224A	2-112A	2-227A (2)	1166-1X1R	1166-1X2R	1162-2
3109-X1	T522G, TR522G	2-234A	-	-	-	-	2-227A (2)	-	116-1X8R	1162-2
2905-X5	T722G, TR722G	2-234A	-	-	-	-	2-227A (2)	-	3983-X2R	1849-1
2906-X2	1021E, 1022E, F1021E, F1022E	2-245A (2)	2-249A (2)	-	2-228A	2-112A	-	1208-1X1R	1208-1X2R	1201-2
2907-X3	F1521F, F1522F, T1522F, TR1522F	2-245A	2-234A (3)	2-249A	-	-	2-238A	3350-X1R	3350-X2R	1792-1
3193-X1	Z2000	2-231A (2)	-	-	2-224A	-	-	4430-X2R	-	4414
3195-X1	Z3200	2-234A (2)	-	-	2-224A	-	-	4495-X2R	-	4242
3197-X1	Z4200	2-231A	2-234A	-	2-234A	-	-	4444-X2R	-	4443

**Pump Repair Kits (continued)**

PART NUMBER	MODEL NUMBERS	MOUNTING RING	PIN DRIVERS	SHIM		
				0.002	0.010	0.020
2904-X2	521E, 522E, T522E, TR522E	-	-	-	-	-
3109-X1	T522G, TR522G	-	-	-	-	-
2905-X5	T722G, TR722G	-	-	-	-	-
2906-X2	1021E, 1022E, F1021E, F1022E	-	-	-	-	-
2907-X3	F1521F, F1522F, T1522F, TR1522F	-	-	-	-	-
3193-X1	Z2000	4432 (2)	4262-X (3)	4439 (8)	4439-1 (2)	4439-2 (2)
3195-X1	Z3200	4432 (2)	4262-X (3)	4439 (8)	4439-1 (2)	4439-2 (2)
3197-X1	Z4200	4453 (2)	4449-X (3)	4458 (8)	4458-1 (2)	4458-2 (2)

Quantities larger than 1 are shown in parenthesis

**Seal Assemblies**

PART NUMBER	MODEL NUMBERS	SEAL SLEEVE	SEAL CLAMP RING	RETAINER RING	SEAL DRIVE PIN	CASE CLEARANCE SHIM		SEAL FOLLOWER	O-RING			SEAL	SHAFT KEY	PAN HEAD PHILLIPS SCREW 6-32X1/4	ROLL PIN
						0.002	0.003		TYPE 1	TYPE 2	TYPE 3				
113-CX	All C-F-DS-DL	1007-X	1008	-	1009	1014	1014-1	1080	2-018	2-224	2-246	2296-X_2	2497	7012-006NC025B (3)	-
5264X_3	All 150	5243	-	2760-88	-	5248	-	-	2-018	2-113	2-260	5242-X_3	4244	-	4984

Quantities larger than 1 are shown in parenthesis

**PUMPS, MOTORS & BYPASS VALVES**



## Swing Check Valves

Swing check valves are used on compressor installations, multiple pump systems and on pumping systems with long discharge lines. Rated 1000 PSI at -20 degrees to 150 degrees F ASTM B-61



PART NUMBER	SIZE
B-375-3/4	3/4" FPT
B-375-1	1" FPT
B-375-1-1/4	1 1/4" FPT
B-375-1-1/2	1 1/2" FPT
B-375-2	2" FPT

## Sight Flow Indicators

The sight flow indicators on this page with the exception of the Taylor, function as a back check valve as well as a flow indicator. Only RegO lets you actually see the product flowing to provide maximum pump efficiency.

### RegO Sight Flow with Back Check

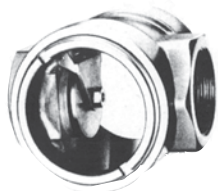

PART NUMBER	INLET/OUTLET
A7794	2" FNPT
A7796	3" FNPT

REPLACEMENT PARTS	
PART NUMBER	INLET/OUTLET
A7794-8	Indicator Assembly, 2"
A7794-9SS	SS Pin, 2"
A7794-10	O-ring, 2"
A7794-11	2" Replacement Glass (2 required)
A7794-12K	2" Gasket (2 required)
A7794-13	2" Retainer Ring (2 required)
A7795-14	Retainer Ring Set Screw 2" and 3"
A7795-8	Indicator Assembly, 3"
A7795-9SS	SS Pin, 3"
A7795-10	O-ring, 3"
A7795-11	3" Replacement Glass
A7795-12K	3" Gasket

### Corken Flo-Chek with Indicator



PART NUMBER	FNPT
FC125	1 1/4"
FC150	1 1/2"
FC200	2"
FC250	2 1/2"
FC300	3"

### Pump Out Adapter with 1" Sight Glass



PART NUMBER	REPLACEMENT PARTS
7550P	Transfer Valve 3/4"
7590U-10	Adapter for Check Lock
5765D	Acme Adapter 1 3/4" M.ACME x 3/4" MPT

*We have everything you need to update your plant.  
Call us for assistance!*

**Strainers**

Protects your pump and meter from foreign material. Ductile iron body with stainless steel 20 mesh screen. Replacement screens and other mesh sizes are available.



PART NUMBER	SIZE
N260-02	1/4" FPT
N260-04	1/2" FPT
N260-06	3/4" FPT
N260-08	1" FPT
N260-10	1 1/4" FPT
N260-12	1 1/2" FPT
N260-16	2" FPT
N260-16F	2" FLANGE
N260-24	3" FPT
N260-24F	3" FLANGE
N260-32F	4" FLANGE

**Flexible Connectors**

Stainless steel braid with schedule 80 nipples for liquid propane. Protects piping from vibration and thermal expansion. Should not be used to correct misaligned piping greater than 3/4" offset. 350 PSI or greater working pressure.



Other sizes available

PART NUMBER	SIZE	LENGTH
FLX1/2-12	1/2" MPT	12"
FLX3/4-12	3/4" MPT	12"
FLX1-12	1" MPT	12"
FLX1-1/4-12	1 1/4" MPT	12"
FLX1-1/4-18	1 1/4" MPT	18"
FLX1-1/2-12	1 1/2" MPT	12"
FLX1-1/2-18	1 1/2" MPT	18"
FLX2-18	2" MPT	18"
FLX2-18-HD**	2" MP	18"
FLX3-22*	3" MPT	22"
FLX2-18F	2" Flanged	18"
FLX3-18F*	3" Flanged	18"
FLX3-24-F*	3" Flanged	24"
FLX4-24F*	4: Flanged	24"

\* Double braided  
Available with weld and flange ends and in different lengths.  
\*\* Heavy Duty

**Scrubbers**



Remove heavy ends from propane vapor. Bottom drain. Top inlet and outlet.

PART NUMBER	DESCRIPTION	BTU
1 SCRUB	Scrubber 1" M.NPT	4,250,000
2 SCRUB	Scrubber 2" M.NPT	14,460,000
3 SCRUB	Scrubber 3" Flange	91,000,000

## Breakaway Stanchion-Bulk Truck and Transport

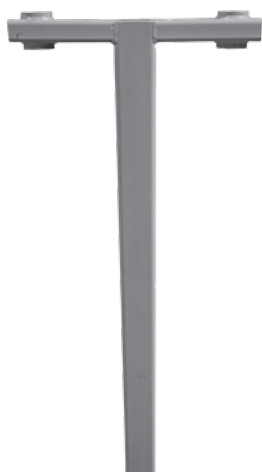

Our B-STAN provides two 2" outlet breakaway protection for standard bulk truck loading. The B-STAN-D has three 2" outlets for combination transport unloading and bobtail loading using a common vapor connection.

PART NUMBER	DESCRIPTION
B-STAN	4" x 4" x 6' Stanchion w/ 2 outlet
B-STAN-D	4" x 4" x 6' Stanchion w/ 3 outlet

## Pull-Away Valves for Transfer Operations

Designed especially to provide pull-away protection for LP-gas and anhydrous ammonia transfer operations including transport and delivery truck loading and unloading, engine fuel container filling and miscellaneous cylinder filling operations.



Brackets

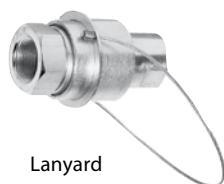

Lanyard

PART NUMBER	INLET/OUTLET CONNECTIONS (F.NPT)	DISCONNECT FORCE (APPROX-LBS)	RECONNECT FORCE (APPROX-LBS)	MOUNTING CONNECTION
A2141A6	3/4"	130	80	Bracket
A2141A6L	3/4"	130	80	Lanyard
A2141A8	1"	75	50	Bracket
A2141A8L	1"	75	50	Lanyard
A2141A10	1 1/4"	160	25	Lanyard
A2141A16	2"	300	50	Lanyard



**Weather Caps**



Provides protection of vertical relief valve riser pipes against rain and foreign material.

PART NUMBER	PIPE SIZE
P770-1-1/8	3/4"
P770-2-3/8	2"
P770-3-1/2	3"
P770-4-1/2	4"

**3-Way Dump Valve for ESV Systems**



This 3-way valve can be used for remote shutdown on pneumatic ESV systems. The 3 openings provide for supply pressure in, line out to ESV or internal valves and exhaust. Can be piped as "Push to Close" or "Pull to Close."

Part Number: 3331

**Nitrogen Tank**



Inert nitrogen gas is the preferred method of charging pneumatic controls for internal and ESV systems in Propane plants. Refillable 60 cu. ft. capacity.

Part Number: Nitro Tank

**Nitrogen Regulator**



Economical, compact single stage design provides efficient and dependable control of inert, nitrogen gas for pneumatic systems controlling internal and ESV systems. Solid brass construction. CGA 580 connects to our Nitro Tank.

Part Number: W-423

**Storage Tank Thermometers**

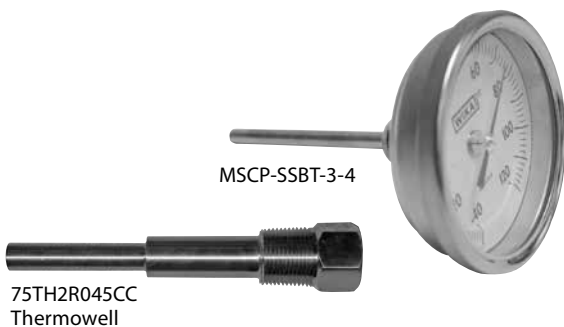

These storage tank thermometers feature a 3" diameter dial with calibration of -40 degrees to 160 degrees F. Sealed dial chamber is dust and waterproof.

PART NUMBER	STEM LENGTH	CONTAINER CONNECTION
MSCP-SSBT-3-4	4"	1/2" MNPT
MSCP-SSBT-3-6	6"	1/2" MNPT

## Corken Compressors

Compressors are extremely versatile as they can be used to transfer liquids between tanks, off-load liquids, recover residual vapor and evacuate vapors for cylinder maintenance. Many propane tanks such as railcars and buried tanks have top unloading connections. A compressor can be the perfect solution for transferring liquids to and from such tanks.

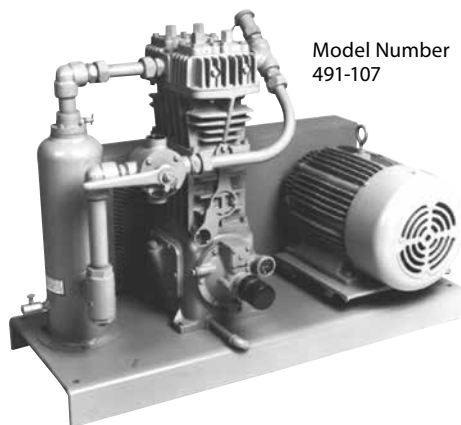

Model Number  
491-107

Add 107 to the model number to include the following: complete gas compressor bulk plant unit with pressure gauges, steel base plate, liquid trap, 4-way valve, strainer, interconnecting piping, adjustable driver slide base, V-belt drive and enclosed belt guard – ready to receive an electric motor driver. Relief valve not included. Corken suggests a 250 PSI relief.

### Mechanical Specifications

SPECIFICATIONS	MODEL SIZE			
	91	291	491	691
Number of Stages	1	1	1	1
Number of Cylinders	1	2	2	2
Bore of Cylinder, Inches (cm)	3 (76.2)	3 (76.2)	4 (101.6)	4 1/2 (114.3)
Stroke, inches (cm)	2 1/2 (63.5)	2 1/2 (63.5)	3 (76.2)	4 (101.6)
Min at 400 RPM	4 (113)	8 (227)	17 (481)	29 (821)
Max at 825 RPM	8 (227)	16 (453)	36 (1020)	60 (1699)
Max Discharge Pres. PSIG (bars)	335 (23.1)	335 (23.1)	335 (23.1)	335 (23.1)
Continuous Duty	5	5	5	5
Intermittent Duty	7	7	7	7
Maximum Allowable Driver Size, HP	7 1/2	15	15	30
Maximum Flow - Propane GPM (m3/hr)*	50 (11.4)	101 (22.9)	215 (48.8)	361 (82.0)

\* Maximum flow is based on 825 RPM or maximum HP, 30 PSID. Capacities are based on 100°F and will vary depending on piping and conditions. Use 5w30 or 10w30 Non-detergent motor oil.

## Corken LPG Compressor Repair Kits

KIT NUMBER FOR COMPRESSOR	3549-X1	3550-X1	3551-X1	3552-X1	3552-X2
MODEL NUMBER	91J3	291	491	690K&P	691M
Suction Valve Assembly	3483-1X	3483-1X	2532-1X	3948-X	3948-X
Discharge Valve Assembly	3485-X	3485-X	2439-X	3857-X	3857-X
Connection Rod Bearing	1367	1367	1491	1719	3542
Packing Sets	1452-1X1	1452-1X1	1452-1X1	1725-2X	1725-2X
Piston Rings	1772	1772	1773	1739	1739
Ring Expander	1775	1775	1776	1740	1740
Gasket Set	2526-XA	1281-XA	1481-X6A	1744-X1A	1744-X3A

## Corken 4-Way Valves

PART NUMBER	DESCRIPTION	USED WITH
3989-X	1" four way valve	Repair Kit 3122-X
3990-X	1 1/4" four way valve	Repair Kit 3123-X
4059-X	2" four way valve	Repair Kit 3130-X

*Krug makes evacuating tanks in the field a snap... saves wear and tear on your bobtails too!*

## Krug Portable Compressor

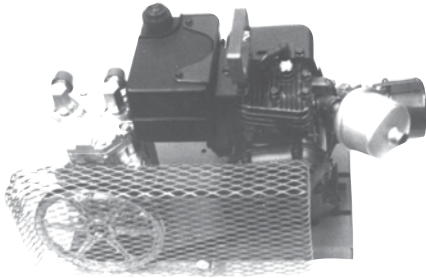

### Tank Evacuation Vapor Compressor

Save your expensive truck pump from damage when evacuating tanks in the field at an 8 to 15 GPM flow rate. Uses include on-site upgrading or downgrading size of storage in the field, and emptying cylinders or tanks in need of repair. This compressor transfers liquid by increasing vapor pressure in tank being emptied and decreasing it in tank being filled. The liquid can be moved into a bulk truck or another bulk tank.

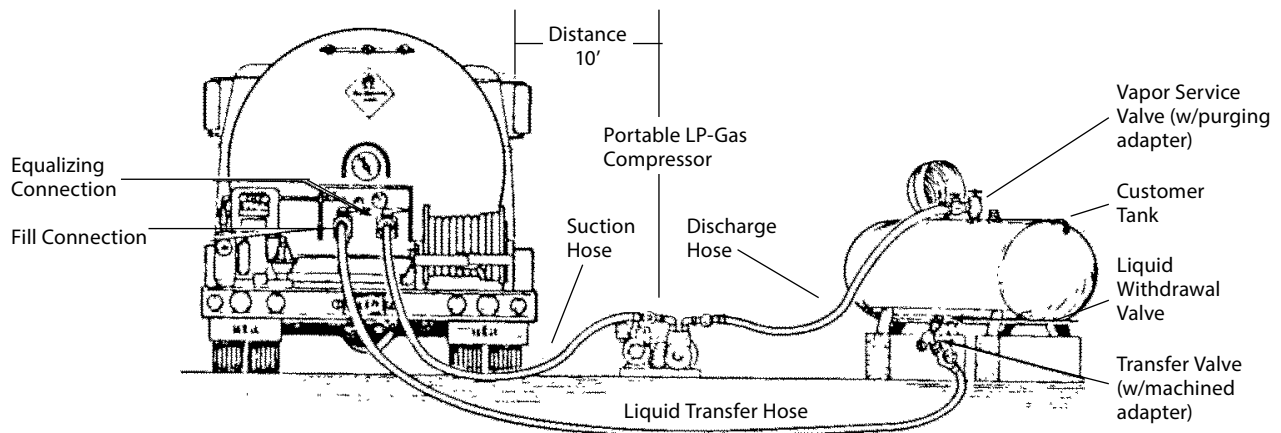

### Using a Portable LP-Gas Compressor

Use 30w or 40w Non-detergent motor oil.

PART NUMBER	FUEL	INLET/OUTLET
H50LPH	Propane	1/2" NPT
*K-GAS	Gasoline	1/2" NPT
*K-EPM	1 HP Explosion Proof Electric Motor	1/2" NPT
16771	Compressor Only	-
PK-C	Valve/Hose Kit (see chart for components)	-
3x927	Pulley 8" Compressor	-
6K041-9	Electric Motor 1 HP	-
029-9888	Key Way for Compressor Pulley	-
4L390	Replacement Belt	-
35411	Shroud	-

\* Complete unit-type indicated

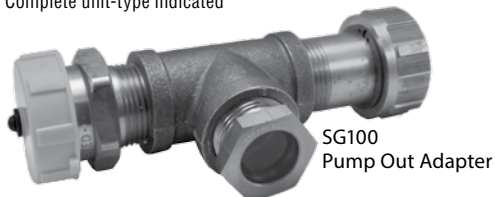

### PK-C Includes:

PART NUMBER	QTY	DESCRIPTION
SG100	1	Pump Out Adapter w/ 1" Sight Glass
LPH-1/2X18P	2	18ft. 1/2" hoses w/ends LPH-1/2" X 18P
LPH-3/4X40P	1	40ft. 3/4" hose w/ends LPH-3/4" X 40P
3171A	2	1 1/4" F.ACME X 1/2" MPT
7572C-14A	1	Check Lok Adapter 3/4" MNPT X 3/4" FNPT
3175	2	1 3/4" F.ACME x 3/4" MPT
3175B	1	1 3/4" F.ACME X 1/2" MPT
75900-10	1	Check Lok Adapter (Union Style) 1 5/8" UNF X 3/4" FNPT
3127U	1	Hydrostatic Relief Valve 450 PSI 1/4" MPT
7550P	1	Transfer Valve 3/4"
5765D	1	1 3/4" M.ACME x 3/4" MPT
600120	1	Coupling SCH 80 3/4"
A7705P	1	Globe Valve 3/4" FPT
A7704P	2	Globe Valve 1/2" FPT

## Purge-It-Vac Adapter



- No labor
- No wasted propane

The purge-it-vac allows you to insert methanol and your first fill of propane without disconnecting the adapter. The purge-it vac adapter is easy to use and meets NPGA #133-899a) on the purging of LP-Gas containers.

Part Number: Purge-It-Vac

## Krug Hand Pump

Simple piston hand pump for uses in filling portable and motor fuel cylinders. Six gallon capacity at 40 strokes per minute. Can also be used to pump methanol into systems. No electricity required.

PART NUMBER	INLET	OUTLET
K-HP	1" F.NPT	3/4" FNPT
K-HPRK	PUMP REPAIR KIT	-

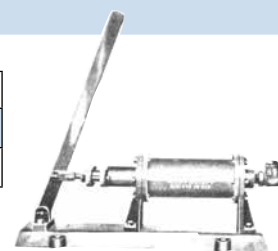

## Purge-It-Safe Cylinder Purge System

Mounts with ease and makes purging of propane cylinders fast and easy! Utilizes vapor as per Pamphlet 58. 3-way valve system includes:

- RegO 3-way valve—A7853A
- Regulator with gauge—597FA
- 4' vent pipe
- Hose 12' with POL fill (2)

Part Number:  
PURGE-IT-SAFE



## Purge Kit LP

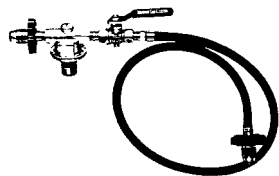

Mounts with ease and makes purging of propane cylinders fast and easy! 3-Way Valve utilizes vapor as per Pamphlet 58.

Part Number: PurgeKitLP

## Pump Station Hose



Completely assembled and ready to use! Dispenser hose 1/2" x 18' with RegO Snap Acting Valve and POL Fill Adapter.

Part Number: PS-Hose

## Liquid Meters

Designed for retail sales dispensing units, the Liqua-Tech Model LPM-102 offers the widest flow range (3-18gpm) available in a meter this size and contains all required accessories including vapor eliminator, strainer and differential valve. ATC available.



**LPM-102 Flowmeter**

PART NUMBER	DESCRIPTION
090534-102	LPM-102 1" Meter

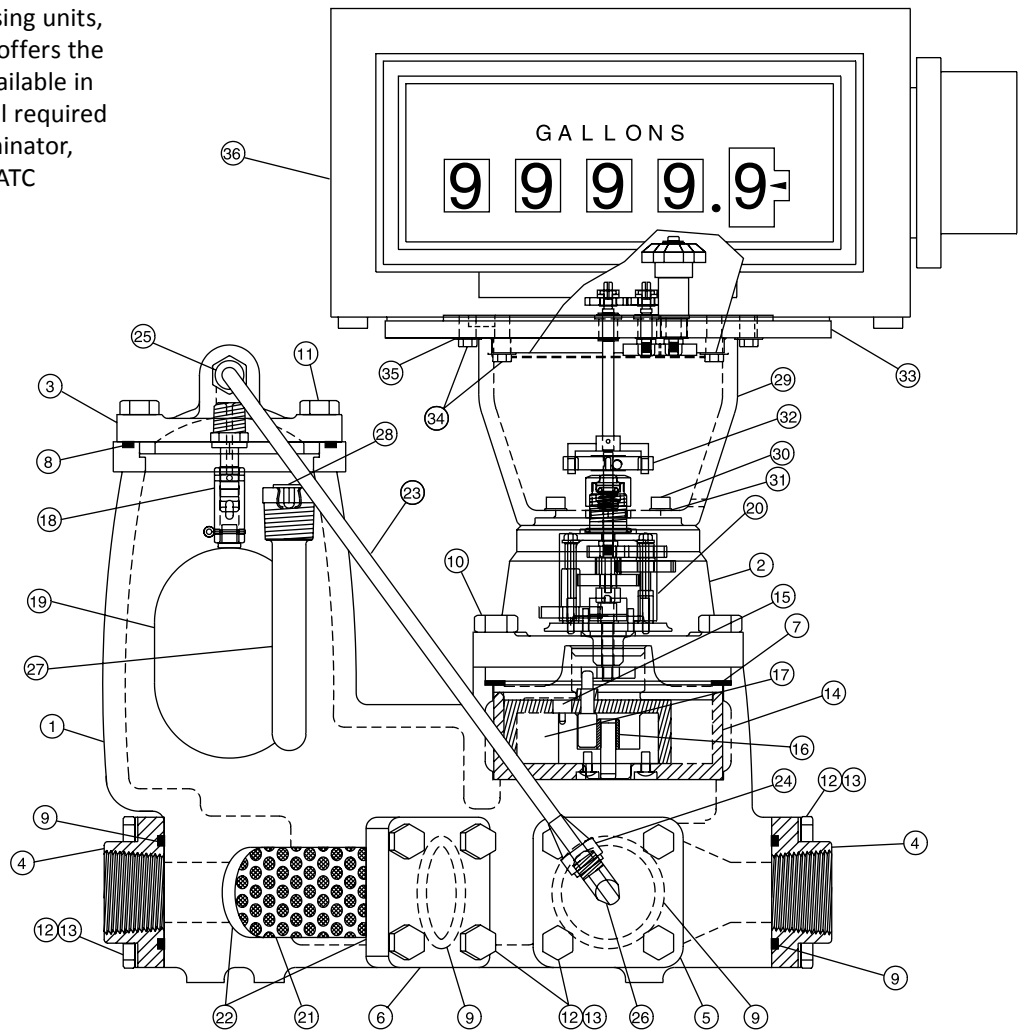

INDEX NO.	DESCRIPTION	PART NO.	INDEX NO.	DESCRIPTION	PART NO.	INDEX NO.	DESCRIPTION	PART NO.
	LPM-102 w/rest register (w/o temp comp) complete	L090028-101	12	Bolt, Hex Head, 5/16 NC x 1	L100063-26	26	900 Elbow, 1/8 NPT x 1/4 Tube	L087195-000
			13	Lockwasher, split 5/16	L100121-010	27	Thermowell	L086666-702
1	Main case housing	L400027-00	14	Measuring chamber	L042075-101	28	Cover, thermowell	L083732-000
2	Cover, main case	L087173-710	15	Seal pin	L042792-000	29	Register adapter tower	L886150-000
3	Cover, vapor eliminator	L087193-710	16	Roller, control	L042086-010	30	Sockethead screws, 10-32 x 3/8	L088524-010
4	Flanges, inlet/outlet	L087180-710	17	Diaphragm	L042791-000	31	Lock washers, split #10	L041211-000
5	Flange, differential valve	L087179-710	18	Vapor return valve	L087190-000	32	Star Drive, with set screw	L082976-001
6	Flange, strainer	L400025-001	19	Float	L087189-001	33	VRA-101-Register gear plate adapter (w/o Temp. comp)	L886101-001
7	Gasket, main case	L004861-016	20	Gear Train, 43.5 ratio, US Gal	L080905-017	34	Cap screws, 1/4-28 x 5/8	
8	O-ring, vapor eliminator flange	L100139-012	21	Stainer 80 Mesh	L101738-001		Drilled	L100061-101
9	O-ring, inlet/outlet flange	L100139-007	22	O-ring, strainer endcaps	L100139-006		Undrilled	L100061-100
10	Bolt, Hex Head 7/16 x 1-1/4		23	Tube assembly, vapor release	L087196-001	35	Lock washers, ext 1/4	L100123-100
	Drilled	L040237-005	24	Nut, flared	L087198-000	36	Register complete, Veeder Root (non printing)	Model # 788700-002
	Undrilled	L040237-004	25	Male connector, 1/8 NPT x 1/4 Tube	L084826-100			
11	Bolt, Hex Head, 3/8 NC x 1	L100067-027						



**Krug makes evacuating tanks in the field a snap... saves wear and tear on your hobbtails too!**

## MA7 and MA15 Meters

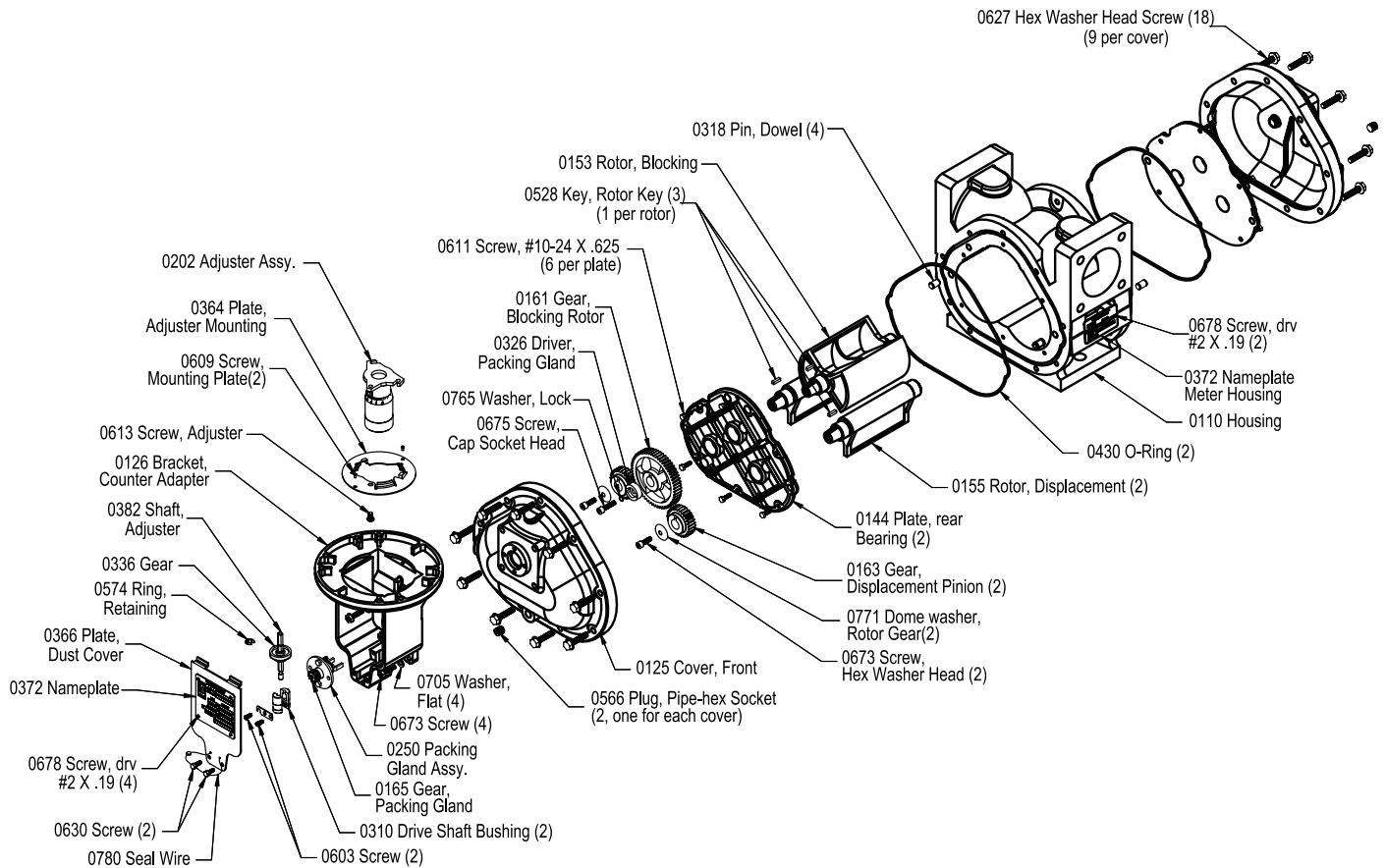

ITEM #	DESCRIPTION	MA7	MA15	ITEM #	DESCRIPTION	MA7	MA15
0110	Housing	49445	501154	0364	Adjuster Mounting Plate	-	42660
0123	Cover	48301	501033	0382	Adjuster Drive Shaft	48287	48287
0125	Rear Cover	48302	501034	0430	O-Ring	09258	09200
0144	Bearing Plate	47668	46732	0528	Key for Blocking and Displacement Rotors	48332	501030
0153	Blocking Rotor	48306	501026	0566	Pipe Plug	06790	06790
0155	Displacement Rotor	48366	501028	0574	Retaining Ring	02188	02188
0161	Gear	47633	47419	0609	Screw	-	00362
0163	Gear	47646	47422	0611	Screw	09079	09079
0202	Adjuster Asseby	49403	49403	0627	Screw	09080	09080
0250	Packing Gland	49561	48616	0630	Screw	09093	09093
0310	Adjuster Drive Bushing	41786	41786	0673	Screw	09027	09084
0326	Driver Packing Gland	48756	48756	0771	Washer	48348	48348
0366	Plate Assembly	49390	49390				

**A8302 Optical Vapor Eliminator**

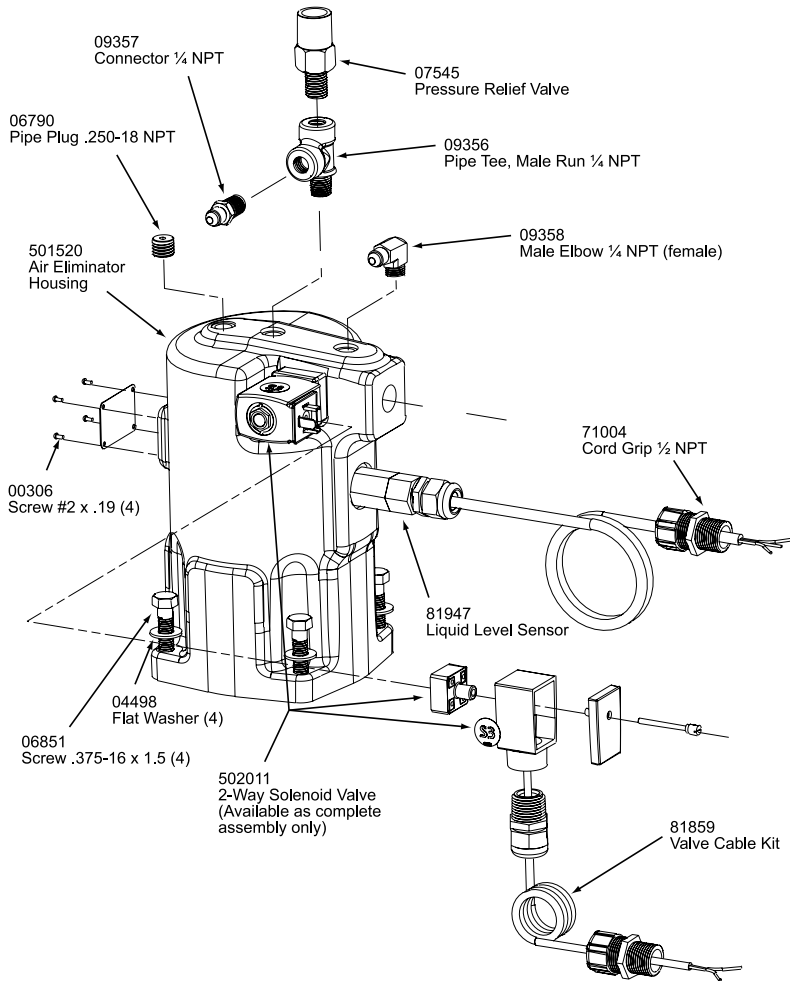

ITEM #	DESCRIPTION
00306	Screw #2 x .19
04498	Flat Washer
06790	Pipe Plug .250-18 NPT
06851	Screw .375-16 x 1/5
07545	Pressure Relief Valve
09356	Pipe Tee, Male Run 1/4 NPT
09357	Connector 1/4 NPT
09358	Male Elbow 1/4 NPT (female)
501520	Air Eliminator Housing
502011	2 Way Solenoid Valve
71004	Cord Grip 1/2 NPT
81859	Valve Cable Kit
81947	Liquid Level Sensor

**A8340A Mechanical Vapor Eliminator**

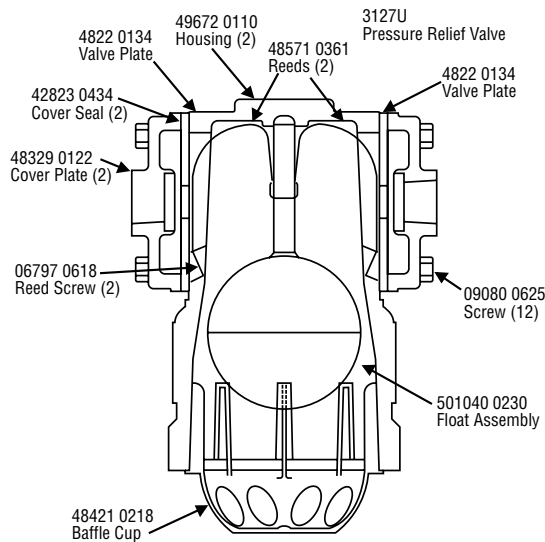

ITEM #	PART	DESCRIPTION
0110	49672	Housing
0361	48571	Reeds
0565	3127U	Pressure Relief Valve
0134	42822	Valve Plate - Standard Vent
0625	09080	Cover Screw
0230	501040	Float and Reed Assembly
0218	48421	Baffle Cup
0618	06797	Reed Screw
0122	48329	Cover Plate
0434	42823	Cover Seal
0136	42824	Valve Plate - Limited Bleed

## FA-7 Strainer

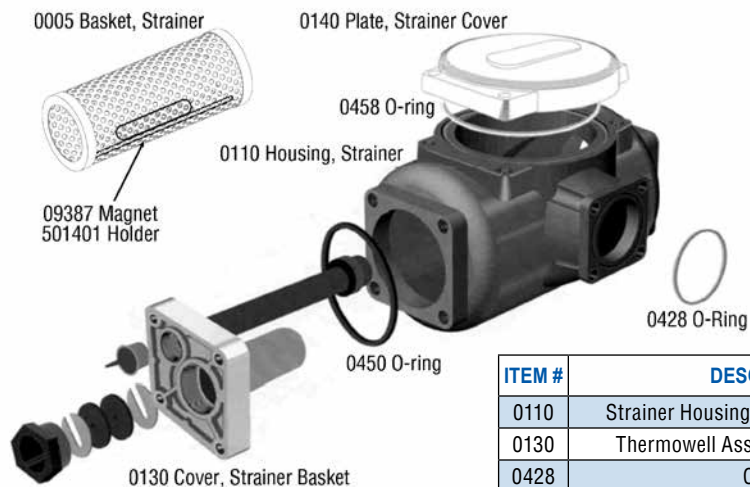

ITEM #	DESCRIPTION	A2343A	A3340A	A3366A
0110	Strainer Housing (Anodized Aluminum)	49425	49426	49426
0130	Thermowell Assembly (Strainer End)	45420	42987	49423
0428	O-Ring	06854	04474	04474
0450	O-Ring	09338	06798	09201
0458	O-Ring (Strainer Cover Plate)	09335	09335	09335
0140	Strainer Cover Plate (Aluminum)	48861	48299	-
0005	Basket Strainer, 40 Mesh SS	-	-	A3430
0005	Basket Strainer, 80 Mesh SS	A2431	A3431	A3431
0005	Basket Strainer, 100 Mesh SS	A2432	A3432	A3432

## A2843 - Differential Valve

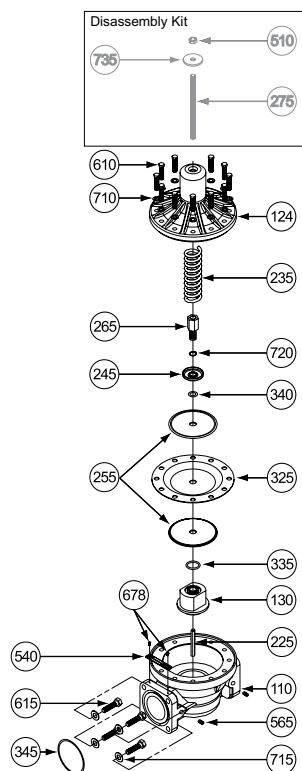

ITEM #	PART #	DESCRIPTION
110	47096	Valve Housing Assembly
124	47302	Valve Cover
130	49947	Piston
235	47305	Spring
245	47307	Spring Retainer
255	47308	Back-up Plate
265	47309	Stand-Off
275	47098	Rod Assembly
325	502078	Diaphragm
335	6856	O-Ring
340	7900	O-Ring
345	7838	O-Ring
510	6055	Nut
565	4759	Plug
610	4655	Screw
615	6851	Screw
678	00306S	Screw
710	9360	Flat Washer
715	4498	Flat Washer
720	6070	Lock Washer
735	6663	Flat Washer

## A2845 - Check Valve

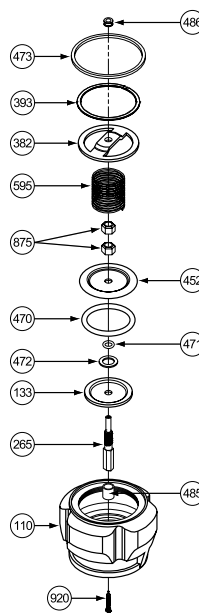

ITEM	DESCRIPTION	PART #
486	Bearing	-
473	O-Ring	06854
393	Spiral Retaining Ring	09137
382	Valve Spring Holder	48337
595	Compression Spring	09138
875	Self Locking Nut (2)	09143
452	O-Ring Retainer	47974
470	O-Ring	09131
471	O-Ring	09140
472	Spacer	47295
133	Piston	47975
265	Valve Stem	-
485	Bushing	07867
110	Check Valve Housing	47973
920	Valve Core	-

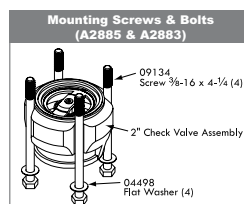



**Liqua-Tech Replacement Parts for Neptune**

PARTS DESCRIPTION	1"	1 1/4"	1 1/2"	2"
Measuring chamber complete	042075-101	043260-101	083271-101	045806-101
Gear train assembly	080905-017	083501-000	084981-000	083502-000
Strainer	087185-000	101433-704	101433-704	101462-004
Vapor release-lower valve housing complete w/float	087188-001	086797-001	086797-001	086798-001
Vapor release main valve complete	-	089274-006	089274-006	089274-006
Vapor check valve	-	084828-000	084828-000	084828-000
Float bulb only	-	082476-001	082476-001	082476-001
Inlet check valve complete	-	084983-704	084983-704	084813-702
U-cup seal	100025-002	100025-002	100025-002	100025-002
Temperature compensator	101080-005	086600-201	-	086702-301
Differential valve stem assembly	100028-011	083768-002	083768-002	083927-002
Reset knob kit improvement 600 reg	101035-005	-	-	-
Improvement kit 600 reg	101035-001	-	-	-
Register mounting studs	084435-000	084435-000	084435-000	084435-000
Thermometer well	086666-702	086666-702	086666-702	086666-702
Thermostat	086646-000	086646-000	086646-000	086646-000
Lower drive bracket comp. 200T gear	084913-000	084913-002	084913-002	084913-002
Lever arm assembly and mounting plate	086649-002	086649-002	086649-002	086649-002
Cover, lever arm mounting plate	086665-000	086665-000	086665-000	086665-000

**Neptune - Veeder Root Conversion Adapters**

PART NUMBER	DESCRIPTION
886100-002	1" Neptune
886101-001	1" Liqua-Tech
886105-001	3/4"-1" ATC Neptune & Liqua-Tech
886205-001	1 1/4"-2" ATC Neptune & Liqua-Tech

**Meter Registers**
**Veeder Root Registers**

788700-002



789002-002

**Neptune Registers**

600 SERIES



800 SERIES

PART NUMBER	DESCRIPTION
788700-002	Veeder Root Register Only
789002-002*	V.R. Register Printer-Face Up Ticket – Right Hand**
100498-009	3/4" Neptune 631 (Code AEAAD)
100498-016	1" Neptune 631 (Code AAAAD)
880030-000	1 1/4"-2" Neptune 833 (Code O)

\* Factory rebuilt register available. Core return required.

 \*\* Left hand register available – special order.  
 Part Number: 789022-701



**Non-locking insulated unions in the Pipe and Fittings Section.**

## Vapor Meters

### Domestic and Commercial Meters

American Meter has a full line of vapor meters. Domestic and commercial meters are compact, lightweight, rugged die-cast aluminum alloy construction. Meters are temperature compensated for accurate measurement.

We carry a complete line of new and reconditioned vapor meters from 3/4" to 4" size. All meters are fully guaranteed for two years from date of installation.



AM250



AC250

### Vapor Meters

PART NUMBER	METER CONNECTION	CONNECTION POSITION	WORKING PRESSURE	MAX INDEX READING	SCFH PROPANE	BTUS PROPANE	CFM AT 60°/11"WC	BTUS AT 60°/11"WC	CFM AT 60°/10 PSI	BTUS AT 60°/10 PSI
AM250	3/4" FNPT	SIDE	5#	Direct Read/CF	160	404,300	-	-	-	-
AC250	1" M. Connector	TOP	5#	Direct Read/CF	160	404,300	-	-	-	-
425HP	1 1/4" M. Connector	TOP	24#	Direct Read/CF	270	694,000	-	-	-	-
425	1 1/4" M. Connector	TOP	10#	Direct Read/CF	260	652,500	-	-	-	-
3000	2" OR 3" FNPT	SIDE	100#	Direct Read/CF	-	-	1860	4,650,000	2370	5,925,000
5000	3" OR 4" FNPT	SIDE	100#	Direct Read/CF	-	-	3100	7,750,000	3950	9,875,000

**SPECIAL SIZES AND LARGER COMMERCIAL AND INDUSTRIAL VAPOR METERS AVAILABLE UPON REQUEST**

### Meter Bars

PART NUMBER	DESCRIPTION
AC250MB	1" Meter Bar for AC250 Meters
RM-MCB-2	2 Meter Setup
RM-MCB-3	3 Meter Setup
20LT	Connectors 1"
30LT	Connectors 1"



AC250MB



RM-MCB-3

## Flathead Lockwing Service Valve 25 PSIG Bronze

Most often used with vapor meters but should be used on all installations to provide a convenient method to shut off and lock service line.



PART NUMBER	SIZE
10621-1/2	1/2"
10621-3/4	3/4"
10621-1	1"
10621-1-1/4	1 1/4"
10621-1-1/2	1 1/2"
10621-2	2"

## Flathead Lockwing Service Valve 100 PSIG Black Iron with Insulated Union

Locking valve plus insulated union. An insulated union should be used any time metallic piping goes underground and then enters a building.

PART NUMBER	SIZE
6266B-3/4	3/4"
6266B-1	1"



## Breakaway Lock

Hidden breakaway feature allows fire department or emergency response personnel access to valves, plant gates, etc. Lock shackle breaks away when struck with hammer or chisel.



PART NUMBER	DESCRIPTION
500BRK	Breakaway Lock

## Barrel Lock



Secures locking valves in closed position. Prevent unauthorized turn-ons when houses or apartments are vacated or when credit is a problem.



PART NUMBER	DESCRIPTION
93180800-X	Barrel Lock
93480800	Key for Barrel Lock

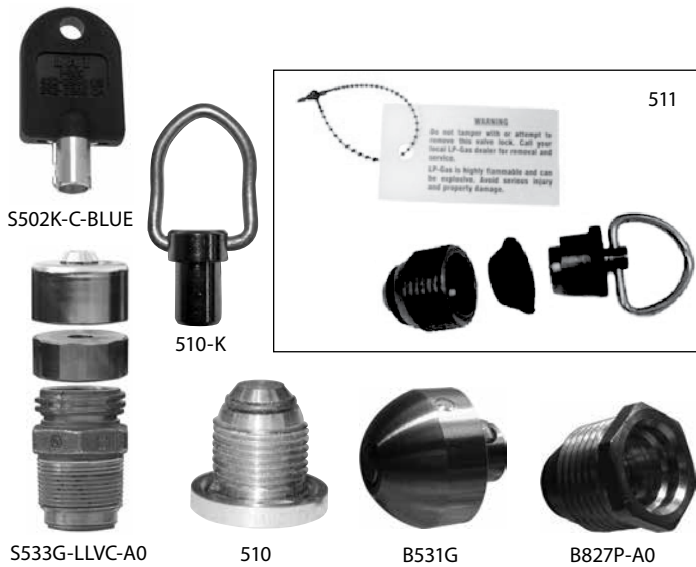

PART NUMBER	DESCRIPTION
510	POL Lock Package (12 Brass Plugs, 12 Lock Collars, 12 Tamper Seals, 12 Warning Tags, Instruction Sheet and 510-K Key)
510-K	POL Lock Key
511	POL Lock Package (12 Brass Locks, 12 Warning Tags & Ties, 36 Seals and 1 Key)
511-K	POL Lock Key
B531G & B827P-A0	POL Lock complete with lock and plug for LP outlet valve keyed alike (key not included)
S502K-C-BLUE	Key (when ordered with lock order) cut uniquely with coe for each company
S533G-LLVC-A0	1 3/4" ACME valve cap lock with brass cap and slip ring with lock keyed alike (key not included)

## Meter Brackets

For American and Invensys vapor meters. Secures vapor meter to house or post.

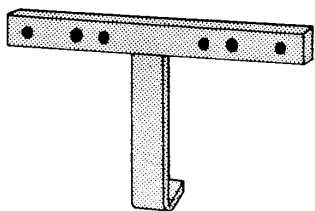

PART NUMBER	SIZE
RW-B	Rockwell/ Equimeter/ Invensys
AM-B	American

## Regulator Assembly LV4403B66RA REG, 6266B-3/4 Valve 2-4" Nipples



Save time and money with our assembled angle regulator manifold. Perfect for vapor meter installations.

PART NUMBER	SIZE
RP-750	3/4"



Check out our fully assembled cabinet on page 134.

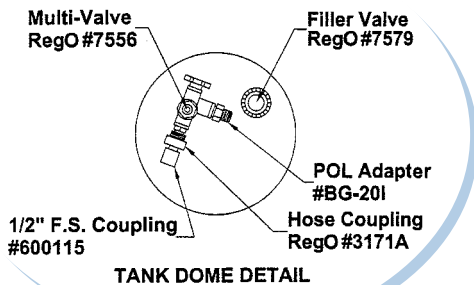
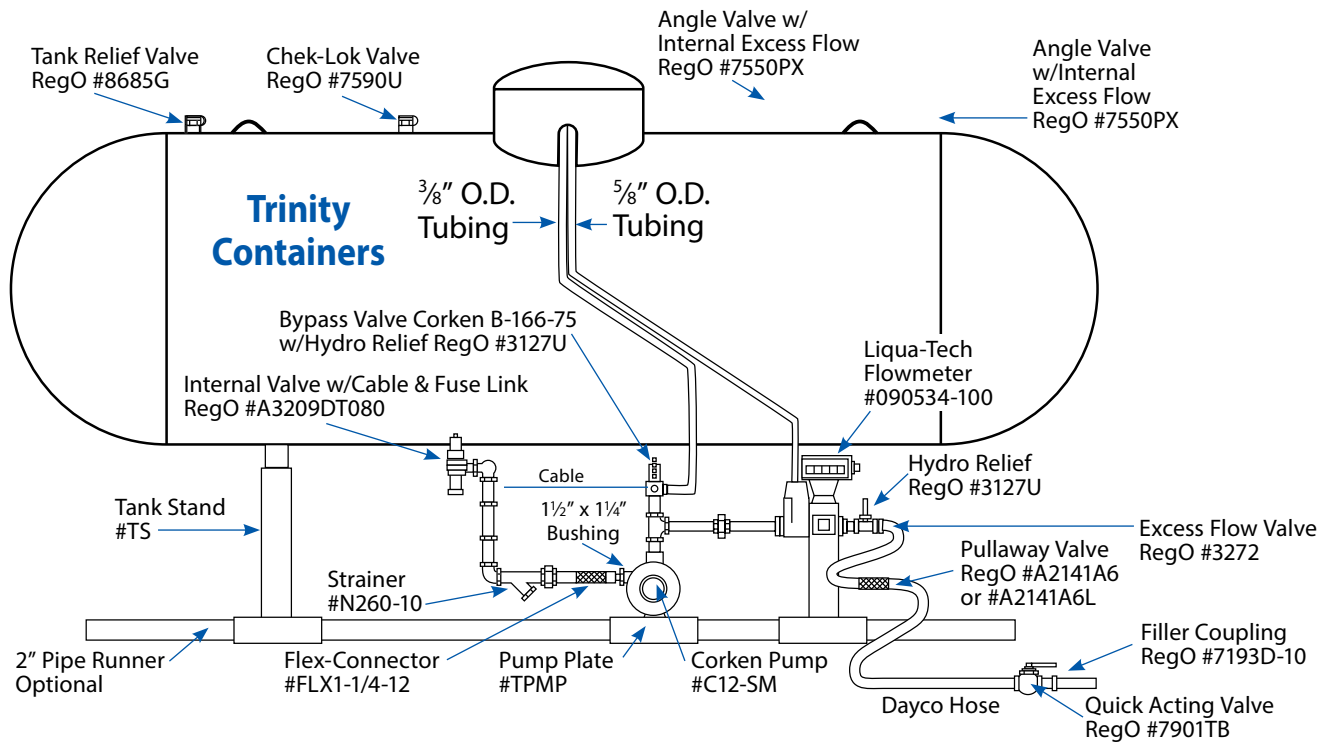

## Tanks for Pump Stations

TANK SIZE	LENGTH	LIQ. OPENING	TOP VAPOR
500	119"	1 1/4"	3/4"
1000	193"	1 1/4"	3/4"

## General Information for Pumping Station Design

1. Choose the proper size tank for the operation, with a 1000 gallon tank for a large industrial motor fueling or a 500 gallon tank for a small 20 LB. refilling.
2. Always use a tank with a bottom withdrawal, preferably a new one. If a used tank is to be used, remove as many heavy ends as possible.
3. Size the pump to the operation. Try to consider future expansion. If a meter is to be used, be sure to use a large enough pump, such as a Corken C12 or larger C13 or C14.
4. Couple the pump to an external by-pass, DO NOT rely on an internal by-pass on the pump.
5. If a meter is to be used be sure it is designed for the operation. Use Liqua-Tech LPM102 or Liquid Controls MA4.
6. Piping should be the same size as your pumps and meters, never smaller. Schedule 80 pipe and Type K copper tubing is required.
7. Safety is a major consideration. Be sure a fire extinguisher and proper warnings and decals are used.

**Call or contact your Sales Representative at Tarantin Industries for further help in designing the best possible system for your operation.**

## Basic Cylinder Filling Valve and Nipple Kit for Corken C-9, C-10 and C-12 Pumps

For installation under tank as pictured on the previous page. Kits are also available for forklift cylinder and motor fueling.

### Corken Pump Options

PART NUMBER	DESCRIPTION
PK-BK	Basic Valve & Nipple Kit
LCMK-01	Meter Piping Kit

Note: Customer supplies 2" pipe for tank stands, Type K Copper and Schedule 80 Black Iron Pipe as needed to suit application.

### PK-BK Basic Valve and Nipple Kit

LEGEND: ❶ = To be used on suction side of pump ❷ = To be used on discharge side of pump  
❸ = To be used on Pump Bypass system

QTY	PART NUMBER	DESCRIPTION
1	A3210A065	1 1/4" Internal Valve ❶
15'	1/8-C	1/8" Galvanized Cable ❶
4	1/8-CC	1/8" Cable Clamps ❶
1	N260-10	1 1/4" Y Strainer ❶
1	600520	3/4" Forged Steel Plug for Strainer ❶
1	FLX1-1/4-12	1 1/4" SS Flex Line ❶
1	603235	1 1/2" x 1 1/4" Forged Steel Bushing ❶ *
2	611029	1 1/4" Forged Steel 90° Ell ❶
2	612235	1 1/4" x 3" Sch. 80 Nipple ❶
2	612265	1 1/4" x 6" Sch. 80 Nipple ❶
1	660130	1 1/4" Forged Steel Union ❶
1	611160	1/4" Forged Steel 90° Street Ell ❷
1	B25-G	1/4" x 1/4" Pressure Gauge Snubber ❷
1	GS-400	400 PSI Pressure Gauge ❷
2	3127U	1/4" Hydrostatic Relief Valve ❷
1	611171	3/4" Forged Steel Tee ❷
2	603125	3/4" x 1/4" Forged Steel Bushing ❷

QTY	PART NUMBER	DESCRIPTION
1	3272G	3/4" Excess Flow, 20 GPM ❷
2	612105	3/4" x 2" Sch. 80 Nipple ❷
3'	LPH-3/4"LT	3/4" x 3' Hose with Ends ❷
1	A2141A6L	3/4" Breakaway ❷
2	603145	3/4" x 1/2" Forged Steel Bushing ❷ ❸
18'	LPH-1/2"	1/2" x 18" Dispensing Hose with Ends ❷
1	7901TB	1/2" x 1/4" Quick Acting Valve ❷
1	7193D-10	POL x 1/4" POL Filler Coupling ❷
1	7193T-10	QCC Type 1 x F.POL Filling Adapter ❷
1	7550PX	3/4" Angle Valve with Excess Flow ❸
1	49IK	5/8" Flare x 3/4" M.NPT Brass Adapter ❸
1	45IIF	5/8" x 5/8" x 1/2" M.NPT Tee ❸
4	NS4I	5/8" Forged Flare Nuts ❸
1	BG20I	5/8" Flare x M. POL Adapter ❸
1	620030	1" x 3/4" Sch. 80 Sch. 80 Swage Nipple ❸
1	600115	1/2" Forged Steel Coupling ❸

\* Omit for C-9 and C-10 Pump Installations

PART NUMBER	DESCRIPTION
TS	Tank Stand Pair W/Meter Plate
TS-1	Tank Stand Pair No Meter Plate
TS-HD	Tank Stand Pair Heavy Duty 1800-1990
TPMP	Pump Plate
TST-1	Step

### OPTIONAL Meter Piping Kit LCMK-01

For installation on tank stand plate

QTY	PART NUMBER	DESCRIPTION
1	A7506AP	3/4" Angle Valve
1	80-103-01	1/2" Ball Valve
1	3171A	1 1/4" Acme x 1/2" M.NPT Vapor Adapter
2	NS4E	3/8" Forged Flare
1	48EF	3/8" Flare x 1/2" M.NPT Adapter
1	48EC	3/8" Flare x 1/4" M.NPT Adapter
1	611014	1/2" Forged Steel 90° Ell
1	611019	3/4" Forged Steel 90° Ell
1	612050	1/2" x 2" Sch. 80 Nipple
2	612115	3/4" x 3" Sch. 80 Nipple
1	660120	3/4" Forged Steel Union

## Valving Kit PK-01

PART NUMBER	DESCRIPTION	QTY
A8017DP	Valve Liquid	1
N260-08	Strainer 1" F.NPT	1
FLX1-12	Flex Conn 1x12" SS	1
3272G	Excess Flow 3/4" MPT x FPT	1
LPH-1/2X10P	1/2" x 10' Hose w/crimped ends	1
7901TB	Quick Act Valve 1/2" x 1/4"	1
7193D-10	POL Fill Adapter	1
7550PX	Angle Trans Valve 3/4" w/excess flow	1
3127U	Hydrostatic Relief Valve	1
H124	Relief Valve 1/4" NPT	1
B25-G	Snubber 1/4" x 1/4"	1
GS-400	Gauge 0-400 1/4"	1
603170	1" x 3/4" Bushing	1
611160	1/4" F.S. 90° Street Ell	1

## Hose Kit PF-01B

PART NUMBER	DESCRIPTION	QTY
LPH3/4" LT	3/4" x 3' Hose w/ends	1
603145	Hex Bush SCH 80 3/4"x1/2"	1
611171	Tee SCH 80 3/4"	1
3127U	Hydrostatic Relief Valve	1
603125	Hex Bush 3/4" x 1/4"	1
612115	3/4" x 3" Nipple sch80	1

## Pipe and Nipple Kit PF-01

PART NUMBER	DESCRIPTION	QTY
611024	Elbow SCH 80 1"	1
611081	Elbow 45 SCH 80 1"	1
612185	Nipple SCH 80 1" x 3"	1
660125	Union SCH 80 1"	1
612215	Nipple SCH 80 1" x 6"	1
603170	Bush Hex 80 1" x 3/4"	1
612115	Nipple SCH 80 3/4" x 3"	1
600609	Reduce Coup SCH 80 3/4" x 1/2"	1
48IF	Connector, 5/8" Flare x 1/2" M.NPT	1
NS4I	5/8" Flare Nut	1
48IK	Conn 5/8" Flare x 3/4" M.NPT	1
612170	Nipple SCH 80 1" Close	1

## Meter Kit - NMK-01

PART NUMBER	DESCRIPTION	QTY
611170	Tee SCH 80 1/2"	1
612050	Nipple, SCH 80 1/2" x 2"	1
600515	Plug Hex SCH 80 1/2"	1
660120	Union SCH 80 3/4"	1
612115	Nipple SCH 80 3/4" x 3"	3
611019	Elbow SCH 80 3/4"	2
3171A	ACME Coupling 1 1/4" F.ACME x 1/2"	1
49EC	Elbow, 3/8" Flare x 1/4" M.NPT	1
48EF	Connector, 3/8" Flare x 1/2" M.NPT	1
102-103	Ball Valve 1/2"	1
612105	Nipple SCH 80 3/4" x 2"	1
NS4E	3/8" Flare Nut	2

## Breakaway Kit PK-01A

PART NUMBER	DESCRIPTION	QTY
A2141A6	Pullaway Valve 3/4"	1

**Tank Stands and Step**

PART NUMBER	DESCRIPTION
TS	Tank Stand Pair w/Meter Plate
TS-1	Tank Stand Pair w/o Meter Plate
TS-HD	Tank Stand Pair Heavy Duty 1800-1990
TPMP	Pump Plate
TST-1	Step
HDP Plate	Dump plate to fit high differential pump
SUBSPP1	Tank Step 12" x 12" w/ 16" Riser

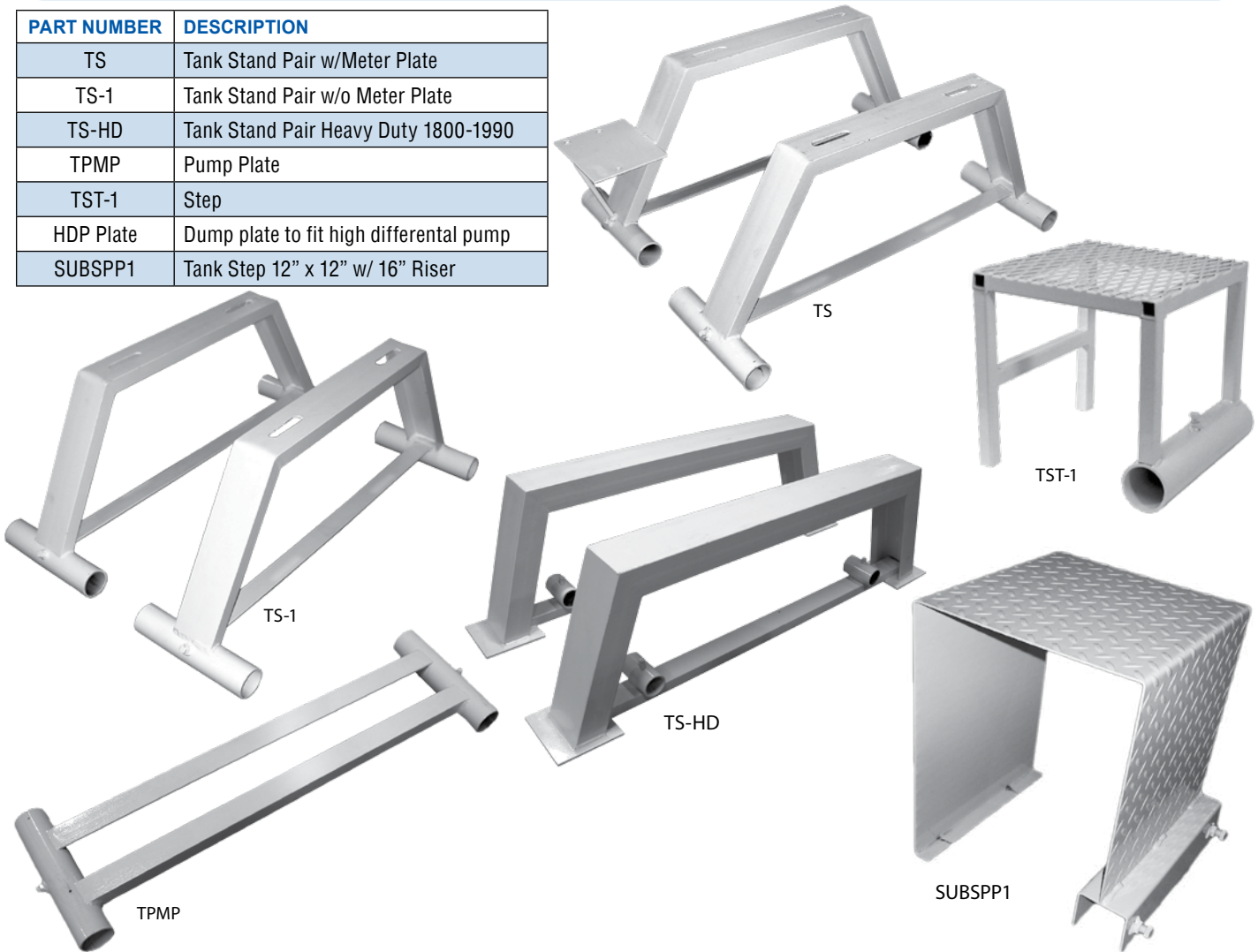

**Detecto Portable Platform Scales**



MODEL	CAPACITY	FRONT OF BEAM
854F100P	1000 lb	100 lb x .5 lb

Platform: 19" x 28"  
 Dimensions: 45"H x 24"W x 35"D  
 Wheels: Large 5" dia. Heavy duty  
 rubolene wheels  
 Shipping Weight: 132 lb.

## Assembled Pump Station Cabinet

*Now available fully assembled and ready to go!*

### Components

- Cabinet
- Tank Stands
- Corken Pump C12 with Switch
- Bypass Valve
- Liqua-Tech Meter
- Scale
- Piping Kit

Part Number: D2A-KIT-ALUM

### Piping Kit includes:

- Internal Valve 1 1/4"
- Hydrostatic Relief Valve
- Angle Valve 3/4"
- Excess Flow Valve 3/4"
- Pullaway Valve 3/4"
- Y Strainer
- Flex Connector
- Forged Steel Fittings
- Schedule 80 Nipples

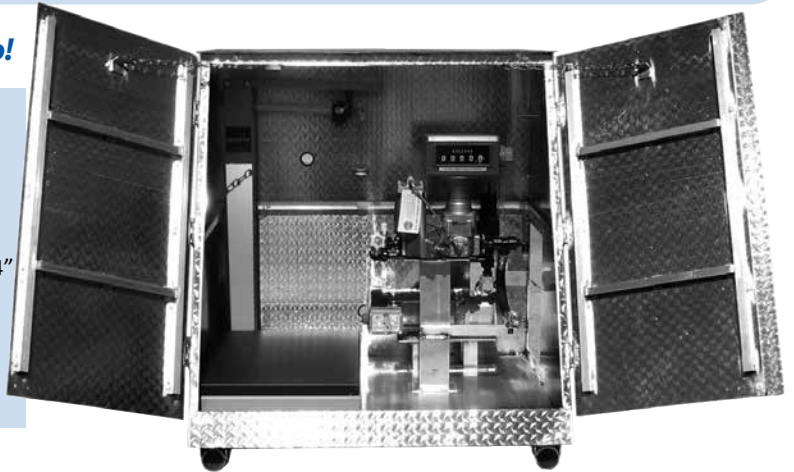

## Pump Station Cabinet

*Protect your pump, meter and scale with this dispensing cabinet.*

Dimensions:

Height 45" • Width 45" • Depth 44"

Part Number: D-2-A ALUM

### Cabinet Piping Kit

Includes all valves, hoses, strainer, flex line, fittings and nipples but not the major components.\*

Part Number: TTC-K

\*TTC-K does not include cabinet, stands, pump with switch and bypass, meter or scale.

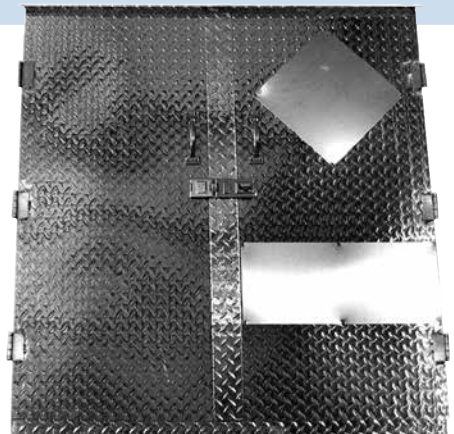

## Dispensing Cabinets

**Protect your pump and meter!**

Dimensions:

Height 56 1/2" • Width 34 1/2" • Depth 16 1/2"

Cabinet only

Part Number: D-1-ALUM

### Assembled Compact Pump Station Cabinet Components

- Cabinet
- Tank Stands
- Corken Pump C12 with Switch
- Bypass Valve
- Liqua-Tech Meter
- Piping Kit includes Internal Valve 1/14"

Part Number: D1-KIT-ALUM (not pictured) **Special Order**

*Custom Cabinets available for other applications.*

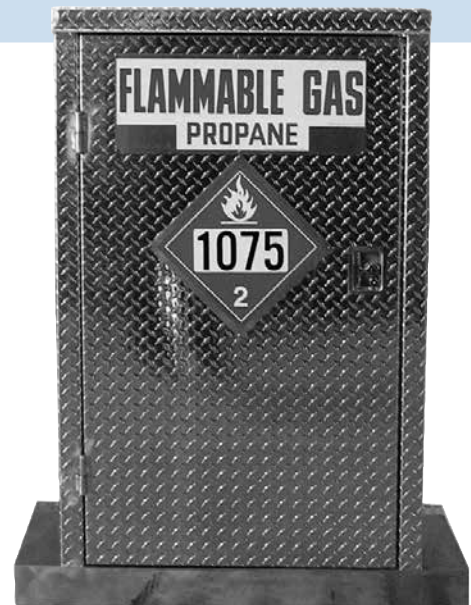



**Cylinder Fill Accessories and Adapters**



Threaded

**QCC Type 1 Regulator Adapter**

Part Number G-1851-A02	70,000 BTU
Part Number G-1851-A03	200,000 BTU

**Gas Grill "Quick Connect Kit"**

(POL x Connection, 1/4" x Plug)  
Eliminates wrenches; fits on all refillable propane cylinders. Provides plug in/plug out use of appliances such as torches, heaters, cookers, etc.

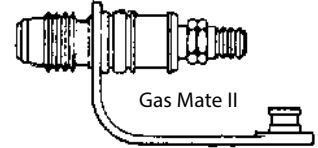

Part Number: F276330



**Pump Station Hose**

Completely assembled and ready to use! Dispenser hose 1/2" x 18 foot with RegO Snap Valve and POL Fill Adapter.

Part Number: PS-Hose



**QCC Type 1 Purge Fitting**

Allows quick purging of QCC Type I Connection

Part Number: G-1850



**POL Plug**

Red plug cylinder valve with warning tag.

Part Number: 737-5

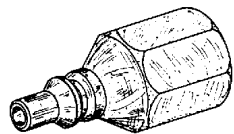

**Fill Adapter for Gas Mate II & Quick Disconnect Valve**

Part Number: F276329



**Gas Grill "Quick Connect" Male Plug Only**

1/4" Male Pipe x Male Plug

Part Number: F276328



**QCC Dust Cap**

Dust cap with lanyard for all QCC valves.

Part Number: DC-QCC1

**Stationary Tank Inverter**

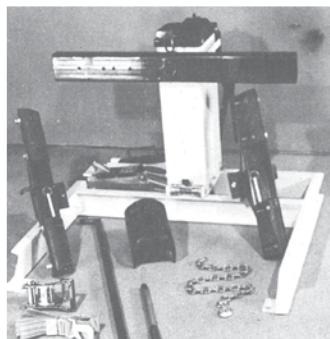

- Capable of handling up to 420 lb cylinder
- 6 position
- Non-marring pads
- Safety-chain
- 4000# hydraulic jack
- 10,000# Strap
- Twin 100# adapter
- Factory assembled & tested

Part Number: DOT-INV.



See the index for our vast array of adapters to get you from here to there.

## RegO Hose End Connectors for DOT Cylinder Filling

PART NUMBER	APPLICATION	INLET CONNECTION	OUTLET CONNECTION	MATERIALS
7193D-10	Filling of DOT Cylinders with POL Connections	1/4" M. NPT	M. POL (CGA 510)	Brass and Stainless Steel
7193U-10	Filling of DOT Cylinders with POL Connections	1/4" M. NPT	Type I Connection (1 5/16" F. ACME)	Brass



7193D-10



7193U-10

## RegO Adapter for DOT Cylinder Filling

PART NUMBER	APPLICATION	INLET CONNECTION	OUTLET CONNECTION	MATERIALS
7193T-10	Converts 7193D-10 Adapter from POL to a Type 1 Connection	F. POL CGA 510	Type 1 Connection (1 5/16" F. ACME)	Brass



7193T-10

## RegO Quick-acting Valves for Cylinder Filling Hoses



Designed primarily for use on cylinder charging hoses to provide fast, convenient shut-off and fast opening.

PART NUMBER	INLET CONNECTION (F.NPT)	OUTLET CONNECTION (F.NPT)	BODY MATERIAL	FLOW AT 1 PSIG (CV) PRESSURE DROP* (GPM/PROPANE)
7901TB	1/2"	1/4"	Brass	1.95

\* To obtain approximate flow at other than 1 PSIG pressure drop, multiply flow in table by square root of pressure drop. Example: 7901TB @ 9 PSIG = 1.95 x  $\sqrt{9}$  = 5.85 GPM/propane. For NH3 flow, multiple propane flow by .90.



Adapts POL filler coupling to motor fuel tanks or multivalves. Every fill station and propane powered vehicle should have one.

PART NUMBER	DESCRIPTION
MSCP-901H	F POL x 1-3/4" F.ACME adapter

## Direct Fired LP-Gas Vaporizer, 40/40H & 80/40H



### Algas Repair Parts

DESCRIPTION	PART NO.		
	40/40H	80/40H	120/60H
Master Spare Parts Kit (includes *kits below)	Pre 10/02 451-504-01	Pre 10/02 452-504-01	-
	Post 10/02 81111	Post 10/02 81112	-
*Thermocouple & Pilot Kit	3-0014	3-0013	41041
*Liquid Inlet Valve Kit	3-0016	3-0016	3-0016
*Capacity Control Valve Kit	3-0017	3-0017	3-0017
*Thermostat	41073	41073	41073
Pilot Assembly Pre '02	-	3-0644	-
Pilot Assembly Post '02	42008	41021	41021
Burner Tips Pre '02	40C14-6	40C14-6	-
Burner Tips Post '02	33581-10	33581-10	33581-10
Burner Regulators	34800	34800	34800



Call our Tech Service Department for installation guides or training.

## Algas Second Sun Flameless Catalytic Tank Heater

PART #	HEAT INPUT	ADDED VAPORIZATION
SS-30	30,000 BTU/h	2.2MMBTU/h @ -20° F
SS-10	10,000 BTU/h	0.5MMPTU/h @ -20° F



## Torex Vertical Explosion Proof Electrical Vaporizer



MODEL NO.	VAPORIZATION GALLON/HR.	CAPACITY BTU/HR.	LIQUID INLET	VAPOR OUTLET	DIMENSIONS			WEIGHT (LBS.)
					D	W	H	
TX25	12.5	1.14 MM	3/4" FNPT	1" FNPT	11 1/4"	9 1/8"	41"	50
TX50	25	2.28 MM	3/4" FNPT	1" FNPT	11 1/4"	9 1/8"	41"	65
TX100	50	4.55 MM	3/4" FNPT	1" FNPT	11 1/4"	9 1/8"	41"	70
TX160	80	7.28 MM	3/4" FNPT	1" FNPT	11 1/4"	9 1/8"	41"	110
TX240	120	10.93 MM	3/4" FNPT	1" FNPT	11 1/4"	9 1/8"	41"	140
TX320	160	14.57 MM	3/4" FNPT	1" FNPT	11 1/4"	9 1/8"	41"	160

### Torex Installation Accessories

PART NO.	DESCRIPTION
41051	Economy Operation Valve (up to 160 GPH)
36923	Valve & Strainer Package
20437	Stand to Raise Unit 12'
5010-3003	Drain Valve Kit
64004	Balancing Orifice

## Zimmer Electric Vaporizer

### Zimmer Vaporizer & Accessories

PART NO.	DESCRIPTION
Z40P	20 GPH Elecgtric Vaporizer Accessories
X1584MN	High Temperature 1/2" Regulator
80887	Tank Oounting Kit
80888	Tank Mounting Valve & Regulator Kit
80885	Wall Mount kit
80892	Strainer & Piping Kit for Wall Mount



## Aquavaire Vertical Waterbath Vaporizers



PART NO.	VAPORIZATION GALLON/HR.	CAPACITY BTU/HR.	LIQUID INLET	VAPOR OUTLET	ELECTRICAL DATA			DIMENSIONS			WEIGHT (LBS.)
					PHASE	VOLTAGE	AMPS	D	W	H	
Q320V	320	29,120,000	3/4" FNPT	2" FNPT	1	120	8.9	69"	27"	70"	1,150
Q480V	480	43,680,000	3/4" FNPT	2" FNPT	1	120	8.9	72"	27"	79"	1,350
Q640V	640	58,240,000	3/4" FNPT	2" FNPT	1	120	10.4	74"	39"	75"	2,100
Q800V	800	72,800,000	1" FNPT	2" FNPT	1/3	120/240	9.1/4.8	74"	39"	88"	2,300
Q960V	960	87,360,000	1" FNPT	2" FNPT	1/3	120/240	11.5/6.2	74"	39"	88"	2,400
Q1120V	1,120	101,580,000	1" FNPT	2" FNPT	1/3	120/240	14.5/8.3	92"	55"	83"	7,100
Q1375V	1,375	125,520,000	1" FNPT	2" FNPT	1/3	120/240	15.0/8.5	92"	55"	83"	7,200

## Indirect Vaporizer/Hydronic Boiler Package



RMI PART NO.	GPH	CAPACITY
HXB320	160	14.5 MM BTUH
HXB500	250	22.9 MM BTUH
HXB640	320	28.8 MM BTUH
HXB1000	500	45.2 MM BTUH

## Algas Filtaire



PART NO.	CAPACITY @ 20 PSIG	SIZE
F0.5	20 GPH	-
F4	102 GPH	1 1/2"
F6	230 GPH	2"
F8	405 GPH	3" 300 # Flange
F12	920 GPH	6" 300 # Flange

## Scrubbers

PART NUMBER	DESCRIPTION	BTU
1 SCRUB	Scrubber 1" M.NPT	4,250,000
2 SCRUB	Scrubber 2" M.NPT	14,460,000
3 SCRUB	Scrubber 3" Flange	91,000,000



## Ransome Waterbath Vaporizers



PART NO.	W/ELECTRIC RELIGHT	CAPACITY GPH @ O.F.	CAPACITY BTU/HR.	DEPTH	WIDTH	HEIGHT	LIQUID INLET	VAPOR OUTLET	WEIGHT (LBS.)
RW100	RW100-E	100	9,170,000	20.5"	14"	48.5"	3/4"	1"	450
RW180	RW180-E	180	16,500,000	20.5"	14"	67.5"	3/4"	1"	750
RW360	RW360-E	360	33,010,000	21.5"	28"	69"	1"	2"	1390
RW540	RW540-E	540	49,510,000	21.5"	42"	69"	1"	2"	1950
RW720	RW720-E	720	66,020,000	21.5"	56"	69"	1"	2"	2510



Don't forget our  
Emergency Response Kit  
on page 156.

## Washers and O-Rings

### Washers – Actual Size

PART NUMBER	SIZE	USE
MSW-4	1-1/4" ACME	Fork Lift Conn.
MSW-3	1-1/4" ACME	*
MSW-2	1-3/4" ACME	*
MSW-5	2-1/4" ACME	*
MSW-6	3-1/4" ACME	*

\* Filler & Vapor Valve & Adapter Connections

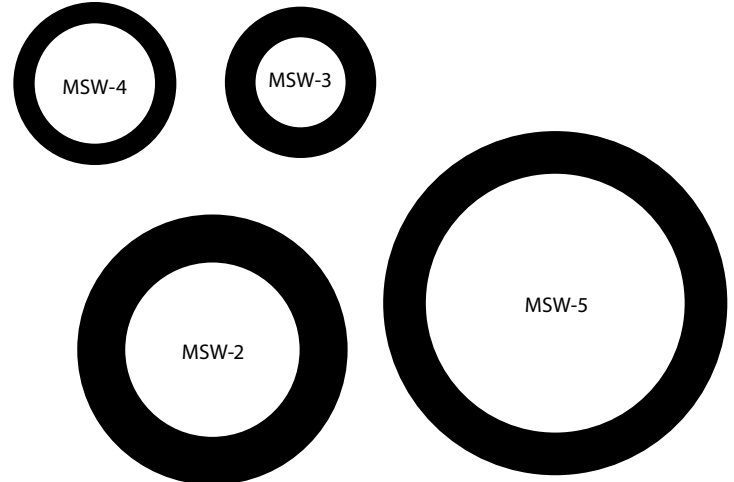

### O-Rings – Actual Size

PART NUMBER	SIZE	USE
2-110	POL	RegO POL Nipple
2114A	1-1/4" ACME	Internal Fork Lift
2-210	1-1/4" ACME	*
2-216	1-3/4" ACME	*
2-223A	2-1/4" ACME	*
2-231	3-1/4" ACME	*
2-238A	4-1/4" ACME	*

\* Filler & Vapor Valve & Adapter Connections

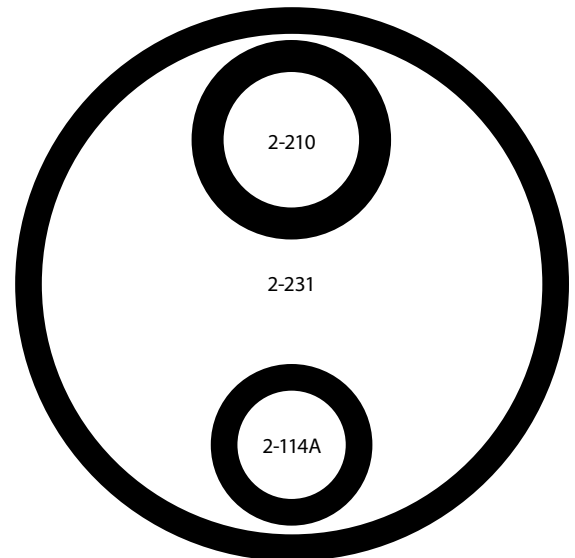
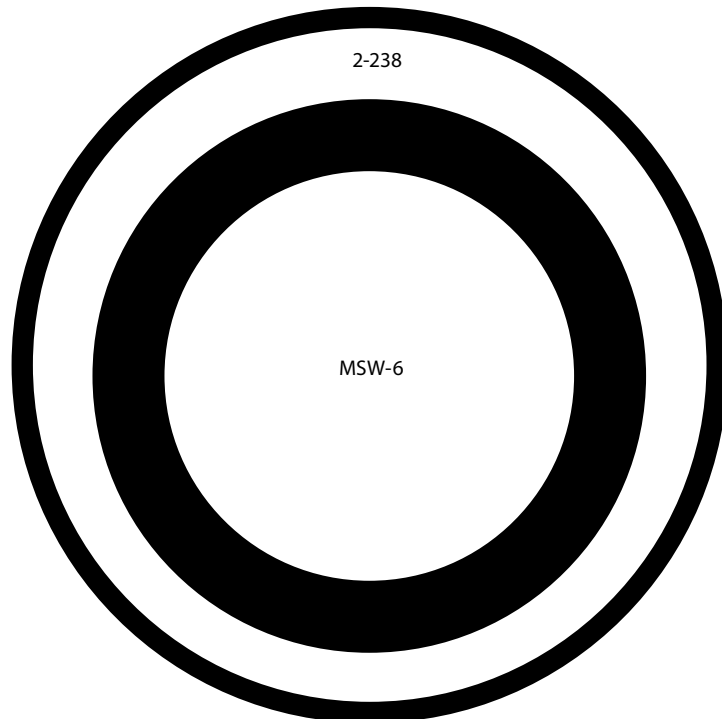
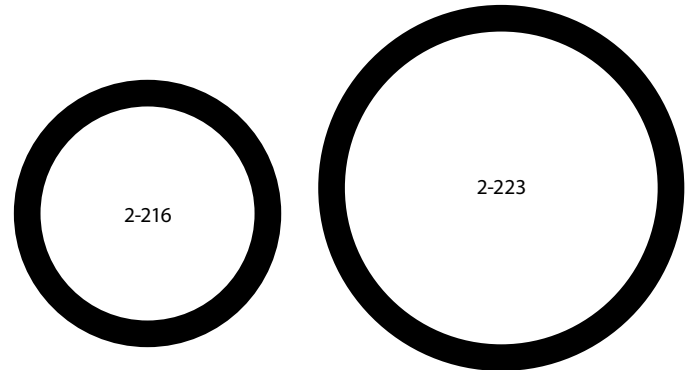

**The EZTC206 Tank Carrier**

EZTC206



**Features:**

- 360° Turning Radius
- Eaton Hydrostatic Transmission
- Cushioned Connection Points
- Automatic Emergency Shut Off
- 4-ply agricultural type tires
- Two 6,500 lbs breaking strength nylon straps with ratchet for wheel jack assembly
- One 18,000 lb breaking strength nylon straps with ratchet for power assembly

**Specifications:**

Weight: 419 Lbs  
 Height: 64 1/2" to top of Handle  
 Overall Width: 62"  
 Length: 67"  
 Construction: 100% Aluminum  
 Lift Capacity: 2,300 lbs

Handles horizontal ASME tanks up to 1,000 gallon capacity.

**Tank and Cylinder Movers**



RTC420NG

**Part Number: RTC420NG (pictured left)**

Motorized dolly with gear drive transaxle for 420 LB (100 gal.) D.O.T. cylinders and 120 gal. horizontal storage tanks. One forward and one reverse gear. 5.0 HP Honda engine, Peerless transaxle.



RTC420H

**Part Number: RTC420H (pictured right)**

Motorized dolly with hydrostatic transmission for 420 LB (100 gal.) DOT cylinders and 120 gal. horizontal storage tanks. Variable forward and reverse speeds. 5.5 HP Honda engine, Peerless hydrostatic transmission. Not recommended for extremely cold climates (use RTC420NG).



RTC420M

**Part Number: RTC420M (pictured left)**

Manual dolly for 420 LB D.O.T cylinders. Three wheel cart with strap, ratchet and hood grab strap for easy attachment. Single handle bar design.



**Part Number: RTC120 (pictured right)**

The RTC120 Adapter is a separate attachment that allows the RTC420 to spot 120 gal. horizontal ASME tanks. Kit includes adapter, strap, ratchet modifications, installation and operating instructions.

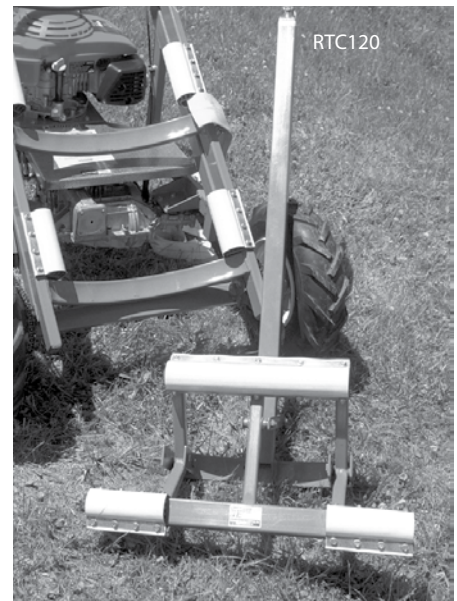

RTC120



**We have the tools you need to do the job right the first time!**

## Slings and Ratchet Straps

### Permaloc Cable Bridle Slings

Galvanized aircraft quality, lifts up to 1000 gallon tanks.

2 Leg Sling

Lifting capacity 4,400 lbs. @60° angle.

Other lengths available.

PART NUMBERS	DESCRIPTION
5X5X2	3/8" x 5' cables
5X5X2S	3/8" x 5' nylon straps
7X7X2	3/8" x 7' cables
7X7X2S	3/8" x 7' nylon straps
10X10X2	3/8" x 10' cables
10X10X2S	3/8" x 10' nylon straps

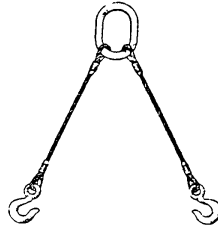

### Round Slings

Useful in lifting cylinder and tanks up to 1,000 gallons.

Part Number: VR1x12-12' Long

Part Number: VR3x14-14' Long

Other sizes and lengths available.

See tag on strap for lifting capacity.

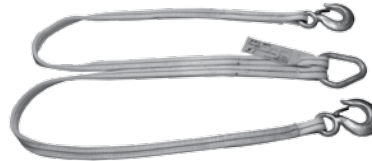
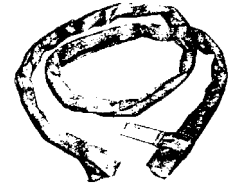

51122

Special orders and other sizes available upon request

### 2" Web Straps with Ratchet

PART NUMBER	LENGTH	END HARDWARE	WORKING LOAD LIMIT
RTO-6	6"	E-Track	4500LB
51124	12'	Chain Extension	3335LB
51154	15'	Chain Extension	3335LB
51122	12'	Flat Hook	3335LB
51152	15'	Flat Hook	3335LB
51272	27'	Flat Hook	3335LB
51128	12'	Snap Hook	3335LB
51158	15'	Snap Hook	3335LB
51278	27'	Snap Hook	3335LB



51124

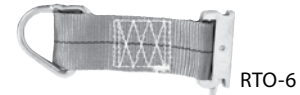

RTO-6



51128

PART NUMBER	DESCRIPTION	MATERIAL
TC-1-A	Tank Saddle	Aluminum

## Hand Trucks

### Part Number HT7-900-4P

Ideal for 420LB cylinders.

Tire and Wheel

Part Number:

101222



### Motor Fuel Cylinder Cart

The RTC33-Scoop 33 LB. Motor Fuel Cylinder Dolly safely transports four stacked cylinders without the use of chain or straps to hold the cylinders on the cart. Scoop and go! Ideal for cylinder delivery trucks, loading docks, gas houses and factories.

Part Number:

RTC33-SCOOP



RTC33-SCOOP

### Part Number HT7325-2

Ideal for 100, 200 or 300LB cylinders.

Tire and Wheel

Part Number: 101222





**Tank-Jak**



The Tank-Jak is designed to provide a portable means of lifting propane tanks for leveling, painting, etc.

Lifting Capacity: 3000 LBS Jack Travel: 13"

Part Number: TANK-JAK

**Wood Safety Plugs**

In the event of a valve being sheared off, hammering in a wood safety plug will allow you to remove the tank to a safe area.

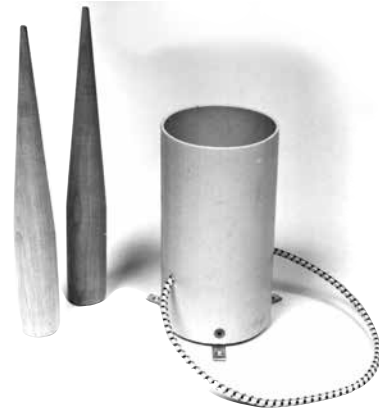

PART NUMBER	DESCRIPTION
WP3/4 X 12	3/4" X 12" - Truck
WP1-1/2 X 12	1-1/2" X 12" - Truck
WP2-1/2 X 12	2-1/2" X 12" - Truck
WP3-1/2 X 24	3-1/2" X 24" - Plant
WP4-1/2 X 24	4-1/2" X 24" - Plant
WP HOLDER	FOR 3/4" -1-1/2 & 2-1/2" - Truck

**Spanner Wrench**



Part Number:  
MSCP-M3385-50

**Acme "J" Wrench**



Solid bar aluminum won't crack or break like other ACME wrenches. For 3-1/4" ACME

Part Number: WR-1

**Chock Blocks**

**Aluminum Magnesium Chock Blocks**

Every bobtail and service truck in your fleet should have 2 chock blocks. See NFPA 58 6.3.8 or DOT Federal Motor Carrier Safety Regulations.



PART NUMBER	SIZE	H	W	L
HWC	Large	8"	8.5"	15"
HGS	Standard	8"	8.5"	12"
MWG	Medium	7"	6"	12"

Part Number: MTV Bracket for chocks

**Reflective Triangles**

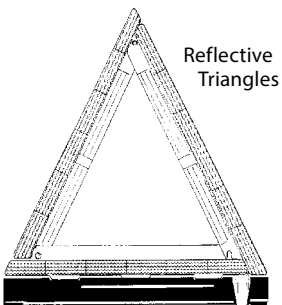

Reflective traffic warning triangles (3) packaged in a handy carrying case. Fold down to an accessible size. Easily seen at great distances. Attractively priced!

Part Number: HWYTRI

## Non-sparking Tools

Beryllium alloy, non-magnetic, and corrosion resistant tools make your job safer.



30-115

PART NUMBER	DESCRIPTION	SIZE	LENGTH
30-115	Brass Hammer	1.5 lbs.	12"
W-211	Pipe Wrench	1" max	10"
W-212	Pipe Wrench	1 1/2" max	14"
W-214	Pipe Wrench	2 1/2" max	24"
W-71	Adjustable	15/16" max	8"
W-72	Adjustable	1 1/8" max	10"
W-73	Adjustable	1 5/8" max	12"
P-39	Pliers	1 1/2" max	9 1/2"
S-49	Screwdriver	6" Blade	10 1/8"
S-50	Screwdriver	8" Blade	13"
S-51	Screwdriver	12" Blade	17"
S-1100	Screwdriver Phillips	6" Blade	10 1/8"



P-39



S-51



### Extend-A-Match

Sturdy alligator clip extends to 26" to reach with matches or small parts.

Part Number: MSCP-HANDILITE

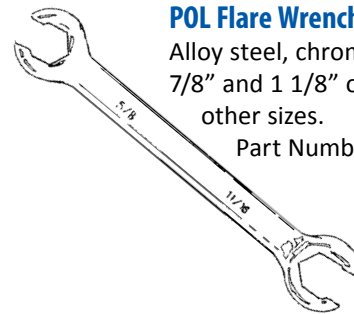

### POL Flare Wrench

Alloy steel, chrome plated with 7/8" and 1 1/8" openings. Call for other sizes.

Part Number: RF55

## Thermocouples - Universal

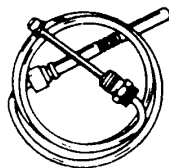

PART NUMBER	LENGTH IN INCHES	DESCRIPTION
LLILR1918	18"	Universal
LR1924	24"	Universal
LR1930	30"	Universal
LR1936	36"	Universal

**Broaches and Reamers**

**Adjustable Orifice Reamer**

The "H" series adjustable size jet cleaners can clean, scrape, size and measure LP-gas or natural gas orifices. Positive oversize protection with absolute control of orifice size, leaving a burr-free, smooth passageway. Drill size numbers printed on each tool shank.

Part Number: P520L - sizes from 50 to 80



**Tapered Broaches**

**Four cornered broaches**

The following are sold in lots of a dozen only.



PART NUMBER	SIZE
GB1008	Tapered from .008" to .017"
GB1010	Tapered from .010" to .017"
GB1012	Tapered from .012" to .017"

**Three cornered broaches**

The following are sold in lots of a dozen only.



PART NUMBER	SIZE
GB3015	Tapered from .003" TO .013" A must for cleaning Pilot Orifices.

**TL050 Burner Broach**

For reaming and cleaning ports. Will fit with TL061 handpiece or TL072 pin vise. Tapers from 1/8" square. Tough and durable.



**TL072 Pin Vise for Gauging Drills**

For holding large and small gauging drills securely while reaming, prevents spinning. This tool is a must when using gauging drills.



**Gauging Reamer Kit**



Have the correct size reamer when you need it. Our kit contains 1 each of GR5020-GR5090 five cornered reamers in a slim plastic case.

PART NUMBER	DESCRIPTION
G5000	Gauging Reamer Kit
G6000	Plastic Case Only - Empty



*Our press check adapter on page 149 is a low-cost alternative to expensive gadgets now on the market.*

## Flaring Tools

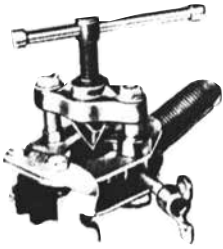

### Rolo-Flair Tool

PART NUMBER	DESCRIPTION	TUBE SIZE O.D.
945TH	Flairing Tool	1/8"-3/4"



### Swing-Release Flaring Tool

PART NUMBER	DESCRIPTION	TUBE SIZE O.D.
2.6033	Flairing Tool	3/16", 1/4"
		5/16", 3/8"
		1/2", 5/8"



### Universal Flaring Tool

PART NUMBER	DESCRIPTION	TUBE SIZE O.D.
525-845	Flairing Tool	3/16"-5/8"

One opening fits all sizes



### General Flaring Tool

PART NUMBER	DESCRIPTION	TUBE SIZE O.D.
195-FC	45° Flairing Tool	3/16"-5/8"

Flairs 7 popular sizes



### Spring Type Tube Bender

Budget priced tool for hand bending soft tubing to any shape without collapsing walls. Special spring steel, nickel finished. End belled for easy tube insertion.

PART NUMBER	SIZE	LENGTH	WEIGHT
LC630E	3/8"	10"	4 oz.
LC630F	1/2"	12"	6.5 oz.
LC630I	5/8"	12"	8 oz.

### Tube Cutter

Rollers have flair cut-off grooves, fold away reamer and spare cutting wheel.



7.0010



7.001

PART NUMBER	DESCRIPTION
7.0010	Tube Cutter for 1/8"-1 1/8"
7.0007	Cutter Wheel for 7.0010 Tube Cutter Small
7.001	Imp. Tube Cutter 1/8"-5/8"
7.0003	Cutter Wheel for 7.0010 Tube Cutter

### Universal Two-Hand Bender for Soft Tubing

- Precision bends soft tubing up to 180° without crimping
- Use on 1/4" to 5/8" soft and medium-soft copper, brass, aluminum, steel and stainless steel tubing
- Marked at 30°, 45°, 60°, 90°, 120°, 135°, 150° and 180° for accuracy
- Lightweight, easy to handle with handles that prevent bruised and pinched knuckles!

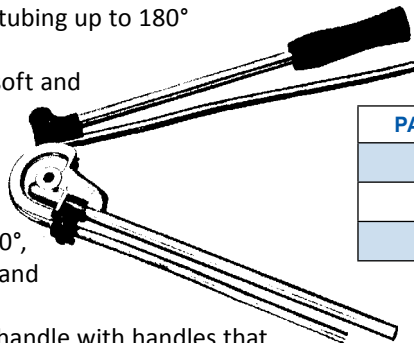

PART NUMBER	DESCRIPTION
2.5131	5/16" O.D. Bender
2.5142	1/2" O.D. Bender
2.5136	5/8" O.D. Bender

**Orifice Kits and Gauging Drill Sets**



**MI-131 – Serviceman’s Orifice Assortment Kit**

**MI-132 – Pilot Orifice Assortment Kit**

**MI-135 – Special LP Plug and Cap Orifice Kit**

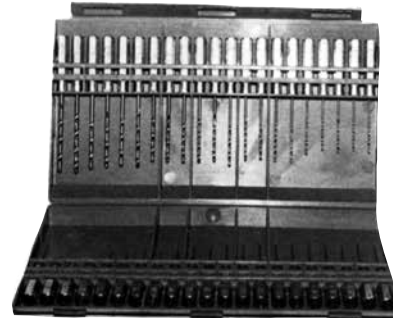

G-4080/G-1939

**G-4080 Gauging Drill Set**

Durable heavy gauge plastic case with clasp, contains set of 41 gauging drills, sizes 40 through 80. Plus 1 G-3020 tapered broach. Snug fit can not fall out. Quick and easy drill removal and replacement.

Part Number: G-4080

**G1939 Gauging Drill Set**

Same as above, contains 21 drill sizes 19 through 39

Part Number: G1939

**Gauging Drills with Handles**

**Exclusive, Pressure-Bonded High-Speed Gauging Drills**

A & F’s exclusive pressure-bonding eliminates obsolete 2-piece construction. Drill and drill handle are permanently bonded to give you 1-piece, trouble-free operation and longer drill life! Sizes 19 through 80. Smaller sizes available. Drill sizes are stamped on side of handle.

Part Number: G-0019 (#19 Drill) through G-0080 (#80 Drill)

**Orifice Adapter Kit**

This adapter kit will renew 80-90% of all orifices. Allows you to also adapt a natural gas orifice down to a smaller LP gas size. An essential item for your serviceman. Includes all tools needed to assemble MI100 adapters: Kit contains 100 each pf MI100-72; 1 each TL061, TL062, TL063, TL064, TL070 and TL074. In a plastic box.

PART NUMBER	DESCRIPTION
MIK100	Master Adapter Kit
SC100	Case only for MIK100
MI-100	#72 Orifice for MIK100



### Dual Range UL-Tube and Inclined Manometer

Use as a regular U-tube manometer to read high-range pressure on the right leg, or as an inclined manometer to read low-range pressure on the bottom leg. Simply incline manometer until fluid level reads zero. No spirt level required. Magnetic clips hold the gauge in position on steel duct surface.

Part Number: 1227-16

Dual Range Manometer

### Water Manometer

Includes: 2 magnetic mounting clips, tube clamp, 2 plastic carrying plugs, and 2 flexible plastic tubing connectors for attachment of 2 ft. 5/16" latex tubing. Fluorescent green dye concentrate furnished.

Part Number: 1222-16

Water manometer same as 1222-16, but includes 2 ft. latex tubing.

Part Number: 1222-16-K



### Low Pressure Test Adapter

Flare fitting unit for testing pressure in copper tubing lines, when test connection on appliance is not accessible.

FOR USE WITH MANOMETER

PART NUMBER	DESCRIPTION
1328	3/8" O.D. Flare
1331	1/2" O.D. Flare
1332	5/8" O.D. Flare

### Manometer

Kit includes 1211-16 slack-tube manometer, carrying case, green wetting agent, adapters and 3' hose. Manometers are as accurate as the finest laboratory "U" gauges—yet they are made to roll up compactly for easy carrying and to withstand rough usage.

Part Number: 1212



### Gauge Oil Red for Manometers

1 pint bottle

Freeze point -65°F

Part Number: A103

Part Number: LATEX'



### Serviceman's Friend

For use with manometer and other applications. One end of fitting has 1/8" pipe thread, 1/4" pipe thread and special 5/16" x 32 thread. Opposite end has regular hose fitting, also 1/8" straight pipe thread. Hose can be used on either end.

Part Number: TL-051

### Pressure Gauge Snubber

Pressure snubber protects gauge from damaging surges and moderates pulsating at the gauge. Pressure snubber 1/4" male x 1/4" female with #54 drill hole.

Part Number: B25-G

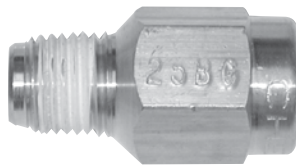

### Magnehelic Gauge

High accuracy within 2% of full scale. Frictionless Magnehelic® gage movement, it quickly indicates low air or non-corrosive gas pressures (either positive, vacuum or differential). Resists shock, vibration and over-pressures. No manometer fluid to evaporate, freeze or cause toxic or leveling problems.

Part Number: MI-230



### Pressure Gauge Adapter

Adapter with 1/4" gauge opening for indicating outlet pressure of a first stage regulator. 1/2" MNPT x 1/2" FNPT Adapter.

Part Number: 1494-1

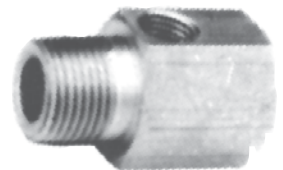

**Press Check Adapter**

Designed for installation in 1/8" FP threaded opening, the PRESS-CHECK Adapter is the key to testing the gas distribution system without breaking the line. UL approved for use in propane vapor systems.

- Check Valve is UL approved for LPG service.
- Ambient temperature range -400 f to +2120 f.
- Operating pressure of 125# PSIG.
- Closing cap provides additional seal of 125# PSIG and is protected by a tamper resistant cap over.



85PC-02

**High Pressure Test Assembly**

Provides for easy and accurate high pressure tests that conform with gas check procedures.

HPTK-2 Test assembly w/POL Hose Inlet



**Low Pressure Test Kit**

Kit includes a pressure gauge reading 0-35" W.C., plastic case and 30" long rubber tubing with bell end.

Part Number: 2434A



**Replacement Parts**

PART NUMBER	DESCRIPTION
2434A-11	Rubber Hose Tip
MSCP-CONE1-M	Rubber Cone Tip

**High Pressure Test Assembly**

For air testing of piping systems includes brass test block 1/2" female pipe x air valve and cap, and high pressure gauge.

Part Number: MSCP-HPTA-30

Range: 0-30

Gauge: PSI



**High Pressure Test Block**

MPOL x FPOL test block with 0-300 PSI gauge and bleeder.

Part Number: 2962



## Digital Manometers

### TPI 600 Series

The TPI 600 Series is a convenient way for service and utility personnel to isolate difficult pressure troubles on propane and natural gas systems.

The TPI 600 series' versatility allows you to perform many critical safety checks with a single instrument.

#### Applications

- Adjust appliance regulators
- Set delivery pressure
- Shut in Test
- Furnace pressure switches

PART NUMBER	INPUT TYPE	UNITS OF PRESSURE	RECORD MIN/MAX
610	Single	Single Unit of Pressure	Yes
615	Single	7 Units of Pressure	Yes
620	Dual - Differential	Single Unit of Pressure	Yes
625	Dual - Differential	7 Units of Pressure	Yes



610

#### Accessories

PART NUMBER	DESCRIPTION
A901	Soft carrying case with shoulder strap



620

## Residential Gas Detectors



PART NUMBER	DETECTS	FEATURES
LP200	Natural Gas, Butane Propane	12 volt plug in
HS80504	Carbon Monoxide, Natural Gas, Propane	Eliminates false alarms, detector is tamper proof, self-diagnostic assures the unit is operating properly, two independent alarms



**Inspection Mirror, Seal Press, and Pilot Cleaning Pump**

**2" x 3 1/2" Inspection Mirror**

Swivel head allows mirror to be positioned at any angle. Safely inspect relief valves and burners.  
Part Number: 72-561

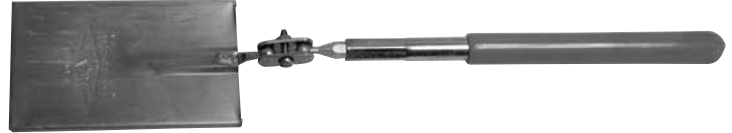

**Pilot Cleaning Pump**

Heavy-duty construction for years of dependable service. Attaches quickly to hot water heater, furnace, stove, and dryer. Fits easily into tool box or pocket. Eliminates the replacement of orifices. Useful in cleaning moisture, carbon and lint from orifices and in removing water from flooded lines. Includes fittings for 1/8" -3/16" and 1/4" pilot tubing nuts.

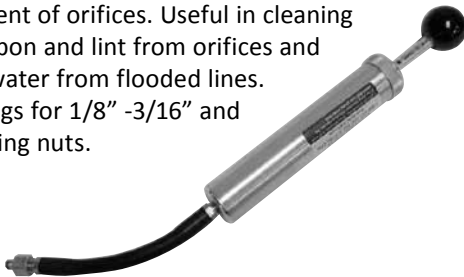

PART NUMBER	DESCRIPTION
AK-114	Pilot Cleaning Pump Kit

**Hand Seal Press**

Available with 1 or 2 dies. Engraved digits. Maximum 3 per die. Required in most states to re-seal registers.



PART NUMBER	SIZE
HSP	5" Hand Seal Press
MS-8	8" Lead Meter Seal

**Manual Propane Flare Tower**

- Flare Up to 529 Gallons/HR
- No Electricity Required
- Compact & Portable Design
- Quick & Easy Setup
- Simple to Use
- Great for Emergency Evacuation Situations
- Stable & Sturdy Construction
- Made in the USA

PART NUMBER	DESCRIPTION
PFM-16LPS	1/2" Manual Flare
PFM-25	25' Hose Extension Kit



PFM-25



PFM-16LPS  
Please note:  
cylinder not  
included

## Combustible Gas Detectors



### Part Number TIF8800X

#### Applications:

- Detects leaks in automobiles exhaust and fuel systems.
- Detects leaks in liquid or gas fire heating systems.
- Safety checks at propane filling stations.
- Search for an arson residue (detects accelerants).
- Detect fuel in marine bilges.
- Check fuel tanks before welding.
- Check manholes/sewers for safety.
- Check for cracked heat exchangers.
- Detect solvent residue.

#### Accessories

PART NUMBER	DESCRIPTION
TIF8801	Replacement Tip
TIF8805	12V Battery Recharge
TIF8806A	Replacement Battery
TIF8803	110V Charger



### Part Number HXG-2D

- Meets UL 913 intrinsic safety
- 10 ppm sensitivity
- Instant response
- Electronic tick rate control
- Settable alarm
- Visual and Audible leak indicator
- 16" Gooseneck
- Soft zippered carrying case

Bar Probe Part Number: 28-44

**Digital Multimeters**



Measures: line and circuit control voltage, current draw of electrical circuits, resistance of components. Tests: continuity in circuits and wires, and diodes for shorts and opens. Three-year warranty.

PART NUMBER	DIMENSIONS
120	6 x 3x 2
133	7.75 x 3.75 x 2.25

**Digital Clamp Meter**

Measures: line and control circuit voltage, current draw of electric circuits, inrush current of motors, relays, and solenoids, and resistance of components. Tests: continuity in circuits and wires.

Part Number: 265



**Closed Circuit Adapter**

Used to make closed circuit tests of thermocouples and thermopiles with suitable millivolt test meters.

Thermocouple Adapter Part Number: 10-038



**Anode Test Kit**

Includes:

- 6A half cell – reference electrode
- Digital multimeter w/wired probes
- Storage case



Part Number: ATK-1

PART NUMBER	DESCRIPTION
6A	6A Half Cell Reference Electrode
16906	Copper Sulfate
17105	Copper Sulfate Anti-Freeze
T&R50060	Flat tip assembly for 6A
T&R50070	Pointed tip assembly for 6B
T&R50300	Copper sulfate crystals
T&R50404	Shunt .001 OHM orange

**Freeze Valve**

Used to test for water content.

AT-1000 Freeze Valve with AT-1016 Filter, AT-1011 Screen and AT-1019 Retaining Ring.

Part Number: AT1000



**TEST IT Test Kit**

Used to test propane deliveries for hydrogen sulfide, ammonia, oil and heavy hydrocarbons. Comes complete with instructions.

Part Number: PTK-1



PTK-1

PART NUMBER	DESCRIPTION
PTK-1	Complete TEST IT Test Kit
5-769-5	Utility Clamp
03-409-22B	Squeeze Bottle
11-838-21	8 oz. Plastic Bottle with Lid
13-5225-01	Litmus Paper, Red (for ammonia)
05-622	Centrifuge Tube
08-562-5B	Graduated Cylinder
T-415	6-1/2" Curved Tweezers
9-65081	Plastic Carrying Case
FP-1	Protective Foam Packaging
EP-1	V2 Sheet, Medium Emery Paper
GW-4	Number 4 Ground Wire
23-173	Monkey Grip Gloves
PTK-IN	TEST IT Instruction Sheet
13-5335-01	Lead Acetate Paper (for hydrogen sulfate)

## Pipe Thread & Gasket Sealer

### PLS2 Premium Thread Gasket Sealer



PART NUMBER	DESCRIPTION
PLS2-1/4 PT	1/4 pint with brush top
PLS2-1 PT	1 pint with brush top

**Note:** This is the gray pipe dope formerly known as John Crane. Contains no Teflon.

### Gasoil Soft Set with Teflon



PART NUMBER	DESCRIPTION
SS04	1/4 pint with brush top
SS08	1/2 pint with brush top
SS16	1 pint with brush top

### Tape II Teflon Tape

PART NUMBER	DESCRIPTION
TT61	1/2" x 520" teflon thread sealer tape
TT54	3/4" x 520" teflon thread sealer tape
1901D	Tape Teflon 1/2" x 520"
1901E	Tape Teflon 3/4" x 520"
TT61	Tape Teflon 1/2" x 520"
YT71	Tape, Yellow 1/2" x 520"
YT75	Tape, Yellow 1" x 520"
ZT13	Tape Teflon 3/4" x 520"
TT54	Tape Teflon 3/4" x 520"



### Free All

PART NUMBER	DESCRIPTION
FA06	Free All- Industrial strength deep penetrating oil. 6 oz..



### Sherlock 5-Second Leak Detector

- Ideal for use with pressurized gas system.
- Ultra-sensitive to low pressure, minute leaks. Retains bubbles; bubble size indicates leak rate.
- Safe for use on polyethylene pipe and fittings as outlined in ASTM test D-1693.
- Service temperature range: -10° F to +160° F
- Wettable: fluid stays on metal longer, it can be used on vertical surfaces.

Part Number: 800-LS5

**For Extra Cold Applications, use Extra Low Temp good to -55° F.**

Part Number: 800-ELS5

PART NUMBER	SIZE	TYPE
300-L32	1 Pint Empty	Brush Top
800-LS3	1 Pint Empty	Spray Bottle
800-LS5	1 Gallon Low Temp	Jug
800-LS5-55	55 Gallon Low Temp	Drum
800-ELS5	1 Gallon Extra Low Temp	Jug

### Gasoil-NT

NT-16 one pint with brush top blue, non-Teflon, grit-free sealant. Can be used on all metals.



**Gloves and Protective Sprays**



**Leather Palm Glove**

General duty protective leather glove. Tuff stretch design—one size fits all. Packed 12 pairs per case.

Part Number: NO. 1

**Halt! Dog Repellent**

Complete with belt clip.

Part Number: HALT

Buy by the case and save!  
Twelve 1 1/2 ounce cans per case

Part Number: HALT-CASE



**Edmont Raised Finish Monkey Grip Glove**

Provides excellent grip for easier, safer handling of wet and dry materials. Tough vinyl coating resists chemicals and abrasion. Comfortable non-woven lining to keep wetness on the outside, warmth and dryness inside. Orange colored, raised finish, large only.

Part Number: 23-173



**Bee Bopper**

Wasp and Hornet Spray.

Part Number: BEEBOPPER

Buy by the case and save!  
Twelve 14 ounce cans per case.

Part Number: BEEBOP-CASE

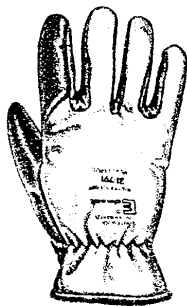

**Winter Tuf-Duk Glove**

Same as above, with foam insulated fit and flexibility for non-slip handling of cylinders and for driving. Jersey lined for comfort, vinyl impregnated. Brown palm; yellow back.

Part Number: 31-791T-M (Medium)

Part Number: 31-791T (Large)

**Hydrex Gloves**

Inner lining helps absorb excess perspiration during prolonged use keeping hands cooler, while significantly reducing hand fatigue. Cut resistant.

Part Number: 11-435-09

Part Number: 11-435-10



**Tub O'Towels**

Knocks out paint, ink, grease, tar and other tough messes. Gentle on hands and environmentally friendly.

Part Number: TUB O TOWELS





See page 86 of the Tank Section for the Minuteman Tank Anchoring System.

## Emergency Response Kit

A complete package in a special toolbox that improves your ability to respond to propane emergencies. It is recommended for placement with key personnel in your company so that emergency response time is kept to a minimum.

Part Number: ERK-1 (Complete Kit)



## First Aid Kits

### Contents of 5001 Kit

- 1" x 3" Band Aids
- Knuckle Band Aids
- 4" Bandage Compress
- 40" Triangular Bandage
- Eye Wash, Pros and Strips
- PVP Iodine Wipes
- Burn Ointment
- Bee Sting Wipes



PART NUMBER	DESCRIPTION
5001	10 Unit Kit - Trucks
5301	24 Unit Kit - Plant

### Contents of 5301 Kit

- 1" x 3" Band Aids
- 2 1/4" x 3 1/2" Band Aids
- Knuckle Band Aids
- Finger Tip Band Aids
- 4" Bandage Compress
- 24" x 72" Compress
- 40" Triangular Bandage
- 4" x 6 yd Gauge Bandage
- Eye Wash, Pros and Strips
- Triple Antibiotic Ointment
- PVP Iodine Wipes
- Burn Ointment
- Cold Pack
- Bee Sting Wipes



**Paint and Underground Tank Protection**

**Brushes**

**Wood Handle • Bristle Brush**

- 2" Part Number: 603-2
- 3" Part Number: 603-3
- 4" Part Number: 603-4



**Metal Paint Tray**

- Heavy Duty
- Extra Deep
- Ladder Rack Legs

Part Number: 7645



**Roller Frames**

Heavy duty 5 wire cage frame for more even paint coverage. Plastic handle with threaded pistol grip.

Part Number: 7411



**Rollers**

9" Synthetic fabric roller with phenolic core for no solvent penetration.

Part Number: 7312-9



- Meets current OSHA & DOT specifications
- Proven performance with tanks
- Superb quality
- Conforms to VOC Regulations

**TANK SOLAR WHITE**

- 1 Gallon Part Number: B54W151-1G
- 5 Gallons Part Number: B54W151-5G

**RUST ARRESTOR WHITE PRIMER**

- 1 Gallon Part Number: B50W24-1G
- 5 Gallons Part Number: B50W24-5G

**BRUSH ALUMINUM**

- 1 Gallon Part Number: B71S200-1G
- 5 Gallons Part Number: B71S200-5G

**TURPOLENE – Synthetic Thinner**

- 1 Gallon Part Number: 130

**SILVER GRAY**

- 1 Gallon Part Number: 8538-1G
- 5 Gallons Part Number: 8538-5G

**SAFETY YELLOW**

- 1 Gallon Part Number: 850

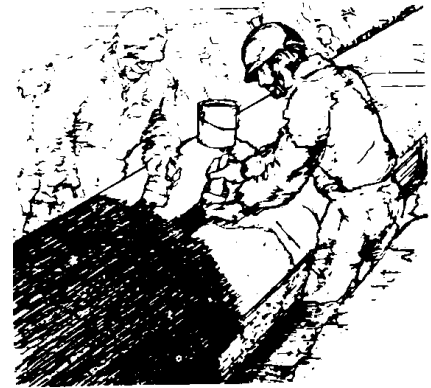

**ROSKOTE R28 Underground Tank Coatings**

For use on underground tanks, one gallon will coat up to 1,000 gallon tank. Easy to apply and considered to be the best in the industry.

- 1 Gallon Pails Part Number: R28-1
- 5 Gallon Pails Part Number: R28-5

**Thinner – For R28 Only**

- 1 Gallon Pails Part Number: 11-1G
- 5 Gallon Pails Part Number: 11-5G

**Tarlon Bottom Guard for Cylinders**

Tarlon Black Mastic is for use on the bottoms of all above ground cylinders requiring corrosion protection. 100 Lb., 200 Lb. and 420 Lb. Note: Not for underground tank coating. See Roskote.

- 1 Gallon Part Number: 353-8-1G

**Miscellaneous Paint Items**

Bucket Bonnet Package of 3  
Part Number: BB-1

Bucket Grid Screen  
Part Number: BG-1

Empty 5 Gallon Bucket  
Part Number: B-1

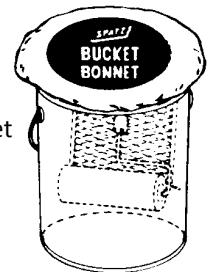



*Do you know the proper amount of methanol to add? Check out the handy chart below!*

## Amerex Fire Extinguishers

Multi-Purpose Dry Chemical  
ABC Stored Pressure Fire Extinguishers-For Use On Bobtails And Transports

- Multi-Purpose
- Dry Chemical
- ABC Rated
- All Steel
- Approved For Use On Propane Trucks



PART NUMBER	DESCRIPTION	RATING
417T	2.5 Fire Extinguisher with Bracket	1A;10BC
500	5 lb. Fire Extinguisher with Bracket	2A;10BC
456	10 lb. Fire Extinguisher	4A;808:C
423	20 lb. Fire Extinguisher	20A;120BC
XTG-8	Cover-20 lb. Extinguisher	-
809	10 lb. Running Board Bracket	-
810	20 lb. Running Board Bracket	-
DT-102	Inspection Tag	-
MS-8	8" Tag Seal	-

## Greenline Pipeline Wrapping Tape

A cold applied, laminated tape for wrapping steel pipe for protection against underground corrosion.

Part Number: Greenline 2 in. x 50 ft.

Part Number: Greenline-4 4 in. x 50 ft.

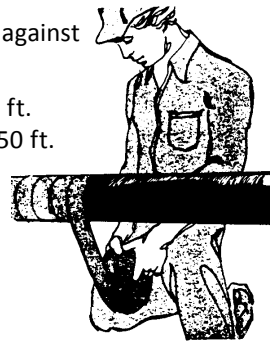

## Potential Meter

Performs required test for anodes, in a very simple manner.

Part Number: 4108



## Roybond Primer

To be used on pipe before applying tape.

Part Number: 747-1 1 Gallon

Part Number: 747-16 16 Oz. Aerosol

## Tank Car Thermometer

**-30°F + 120°F Range**

Thermometer Only Part Number: MSCP-A12

Thermometer & Armor Part Number: MSCP-A12A



-30° to +120° Range, 12" Long



## Tank Inspection and Recertification Tools

### Methanol Injector

For use in the field on containers suspected of having moisture in them.

- Holds 5 ounces
- Empties in 5-10 strokes
- Check valve prevents backflow of propane pressure.

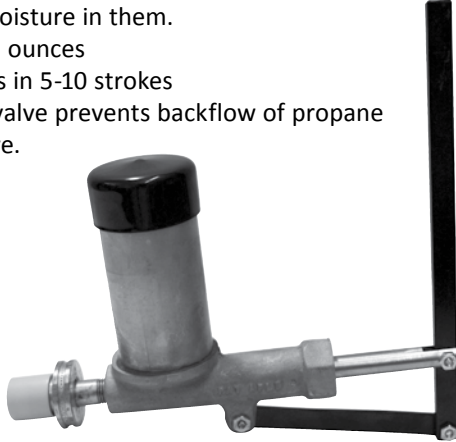

PART NUMBER	DESCRIPTION
ABJ-2	Methanol Injector W/Soft Hose Handwheel POL
ABJ-AA	Adapter Female POL x 1 3/4 Acme for Connection to Fill Valve
ABJ-RK	ABJ-2 Repair Kit O-ring check assembly
ABJ-POL	Replacement POL End

CONTAINER TYPE	MINIMUM VOLUME METHANOL REQUIRED
100LB DOT Cylinder	1/8 pt. (2 fl. ozs.)
420LB DOT Cylinder	1/2 pt. (8 fl. ozs.)
500 gal. tank	5 pts. (2 1/2 qts.)
1000 gal. tank	10 pts. (1 1/4 gal.)
2000 gal. tank	20 pts. (2 1/2 gal.)

\* Important - Avoid substitutes - they will not work. The secret of the effectiveness of methanol over all other alcohol is its high affinity for water plus a boiling point lower than all other alcohols, and most important: a boiling point lower than water.

### Gravity Methanol Injector

- Easy to Use
- Inexpensive
- 1 Quart Capacity
- Connects to Vapor Equalizing Valve of ASME Tanks

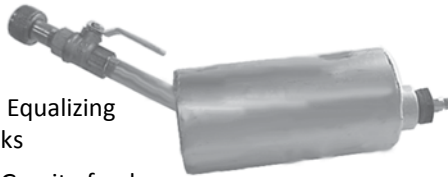

Part Number: I-100 Gravity feed methanol injector

### Large Capacity Methanol Injector

The Inject-1 is an injector for adding methanol or motor fuel additives to bulk storage or vehicle fuel tanks.

- Safe
- Simple
- Easy to Carry
- 1 Gallon Capacity

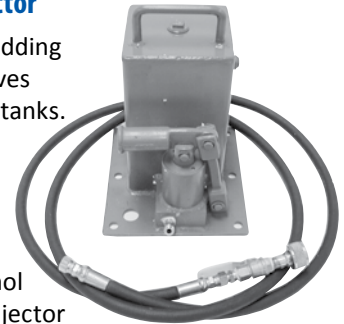

Part Number: Inject-1 Methanol quick injector

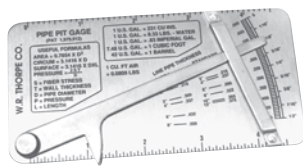

### Pit Gauge

For accurate and convenient measuring of cylinder rust pits, gouges and dents as required for D.O.T. visual inspection of gas cylinders.

Fast and easy way to check rust pits.

Highly polished stainless steel

gauge comes in pocket size leather case.

Model # PG-1

### Scribe with bent points .005 & .010

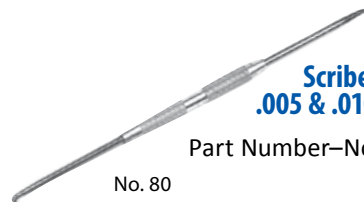

Part Number-No. 80

No. 80

### Purge Kit LP

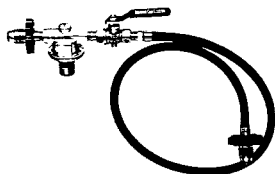

Mounts with ease and makes purging of propane cylinders fast and easy! 3-Way Valve utilizes vapor as per Pamphlet 58.

Part Number: PurgeKitLP

### Steel Stamp Sets\*

1/4" Part Number: SS-0-9-1/4"

3/8" Part Number: SS-0-9-3/8"

3/16" Part Number: SS-0-9-3/16"

\* All sets include 0 to 9 and the letter "E." Individual Letters and Numbers Available

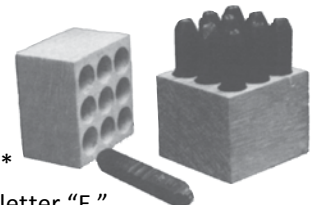

## Tools and Accessories

### Bot-L-Rench

For removing and installing valves in DOT cylinders and lift truck cylinders.



PART NUMBER	SIZE
20-1	Plug
20-2	Wrench
20-3	Handle
20-4	Chain Vise Assembly
20-5	Plumbers Pot Wrench
20-7	Motor Fuel
20-8	QCC Valves

### Cylinder Vise Model CVM-200

Holds 12" through 15" diameter sizes with easily adjustable snap-action latching mechanism and removable inserts. Can be mounted on post or wall.

Shipping weight 46 lbs.

Part Number: CVM-200

#### Also available:

Optional Mounting Base, Part Number: CVM 200-S



### Offset Wrench for Removing Valves in Cylinders w/Collars

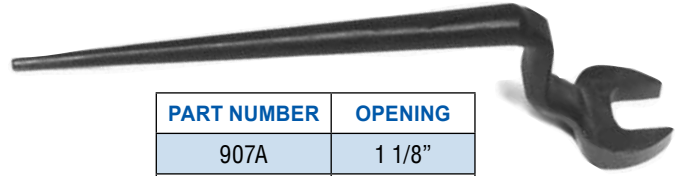

PART NUMBER	OPENING
907A	1 1/8"
908	1 1/4"
909	1 7/16"
909A	1 1/2"

### OPD Wrench



The TW-3 quickens installation and removal of QCC-1 cylinder valves from DOT containers. The wrench works on all style 1 (QCC-1) valves, particularly the fixed handwheel OPDs that are mandated for all 5 to 40LB cylinders. A bleed orifice safety feature will indicate any pressure remaining in the cylinder before removing the valve by simply opening the valve slightly prior to loosening. The wrench is made from tough, durable alloy and forged steel components.

Part Number: TW-3

### Wall Cylinder Vise Model CV-1

- Holds up to an 18" diameter cylinder
- Flexible heavy-duty, non-slip nylon straps prevent damage to cylinders
- Parts tray included
- Ships UPS!
- Minimal floor space needed

Part Number: CV-1



**The Anatomy of a Hannay Hose Reel**

- 1 **Bearings** Weight of spool and hose is supported by bearings.
  - 1a **Back Bearing**
  - 1b **Front Bearing**
- 2 **Disc** Rolled edges prevent hose damage and add rigidity to disc. Additional strength is provided by a concentric rib.
- 3 **Drum** Roll formed steel with full length weld.
- 4 **Tie Rods** join discs and drum to form spool. Reinforced with pipe spacers for rigidity and strength.
- 5 **Chain and sprocket drive** Provides smooth positive rewinding on powered reels.
- 6 **Rewind motor** Electric rewind motor is shown. Compressed air or hydraulic motors can be used.
- 7 **Hub assembly** includes the fluid hub, the outlet riser and the reel axle. Fluid passes from the swivel joint inlet through the hub assembly, to the hose.
  - 7a **Outlet riser** Contoured to match the curve of the reel drum so hose will wrap smoothly.
  - 7b **Fluid hub**
- 8 **Swivel joint inlet** permits reel to rotate freely while connected to the fluid source. Joint is not used as a bearing. Straight or 90 degree swivel joints are available for most models. (Flexible connector must be used between swivel joint and inlet piping or warranty will be void.)
- 9 **Brake/Rewind Assembly** Bevel gear rewind has an adjustable tension brake. Rewind and braking device vary with different models.
- 10 **Front Frame**
- 11 **Back Frame**
- 12 **Front Foot**
- 13 **Back Foot**

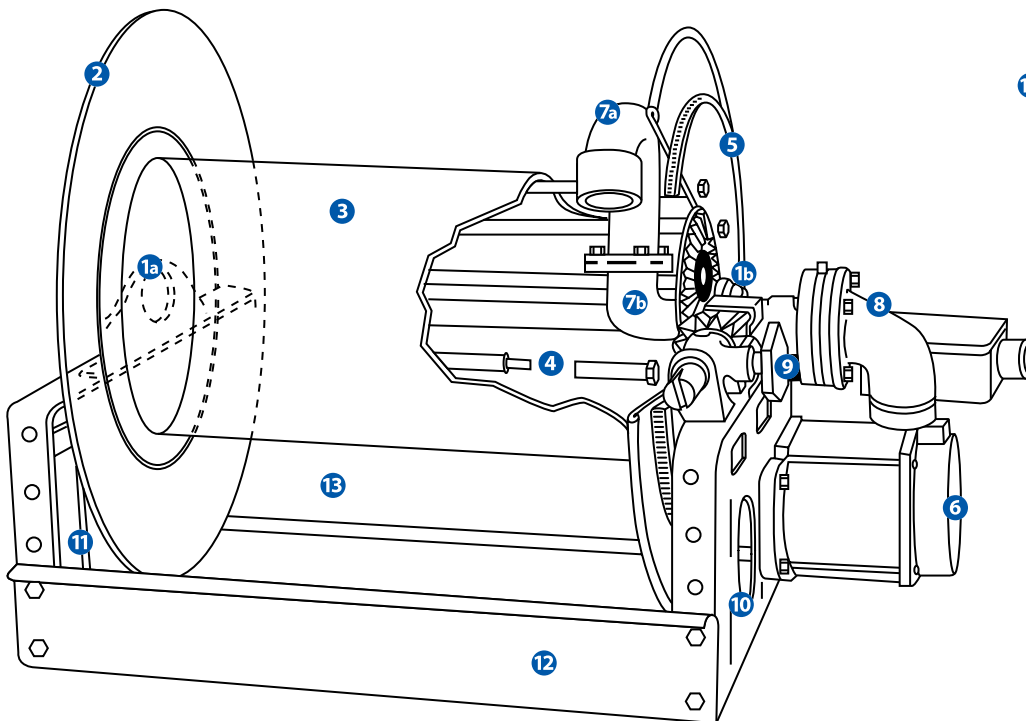

**General Specifications of Hannay Hose Reels**

**Construction:** Frames, discs and drum are fabricated of heavy gauge steel. Bearings are self aligning. Malleable iron and steel are used for hose reel hub assembly, outlet riser and swivel joints. Stainless steel, aluminum, bronze and other alloys, and special swivel joint packing, can be supplied to meet special requirements.

**Finish:** Standard finish is oven cured enamel. Finishes other than standard, such as special primers, polished aluminum, unpolished stainless steel and hot dipped galvanized may be specified at extra cost.

**Temperatures & Pressures:** Standard reel construction will handle most liquids or gases at temperatures ranging from -20 degrees to +400 degrees F (-29 degrees to +204 degrees C). Operating pressures available up to 10,000 psi (695 BAR) depending on the specific reel series. These operating pressures and temperatures are shown on descriptive pages in each product catalog. Reels to operate at pressures and temperatures other than standard are available at extra cost.

**Shipping:** Reels are shipped completely assembled, ready to install. Installation instructions are supplied with each reel.

# HOSE REELS

## EPB

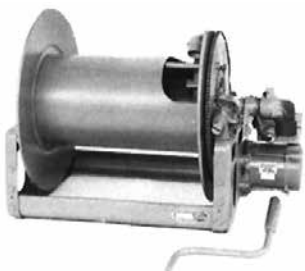

Optional auxiliary crank rewind shown

## EPBGMT



Guidemaster top mount

## EPBGMB

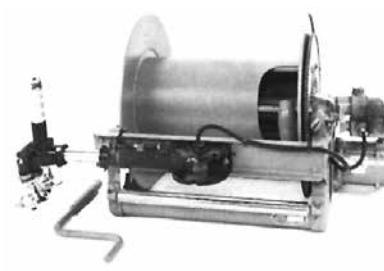

Guidemaster bottom mount

### Helpful Information When Ordering:

- Entire model and serial numbers
- Size and location of inlet and outlet, as you face reel

- Motor location and voltage
- Special options
- 90° or straight swivel joint
- Hose I.D., O.D. and length

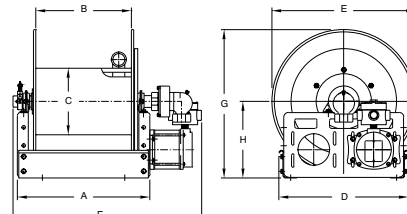

PART NUMBER	STANDARD ELECTRIC REEL	GUIDE MASTER BOTTOM MOUNT	GUIDE MASTER TOP MOUNT	HOSE CAPACITY OF REEL IN FEET			REEL DIMENSIONS IN INCHES								
				I.D.	3/4"	1"	DIMENSIONS E, F, AND G ARE OVERALL ENVELOPE DIMENSIONS								
				O.D.	1 9/32"	1 9/16"	A	B	C	E	F	G	H	J	K
28-23-24	EPB	EPBGMB	EPBGMT		225	140	25 1/2	20	10 1/2	23	32	23	12	19	6 1/2
30-23-24	EPB	EPBGMB	EPBGMT		250	150	27 1/2	22	10 1/2	23	34	23	12	19	6 1/2
32-23-24	EPB	EPBGMB	EPBGMT		275	175	29 1/2	24	10 1/2	23	36	23	12	19	6 1/2
22-28-29	EPB	EPBGMB	EPBGMT		275	200	19 1/2	13 1/2	10 1/2	28	26	30	14 3/4	26 1/2	6 1/2
22-25-26	EPB	EPBGMB	EPBGMT		210	130	19 1/2	13 1/2	10 1/2	25	26	27	15	25	6 1/2
24-25-26	EPB	EPBGMB	EPBGMT		230	150	21	15 1/2	10 1/2	24 3/4	24 1/8	27	15	25	6 1/2
26-25-26	EPB	EPBGMB	EPBGMT		275	175	23	17 1/2	10 1/2	25	30	27	15	25	6 1/2
22-33-34	EPB	EPBGMB	EPBGMT		250	150	19	13 1/2	10 1/2	31 3/4	36 5/8	33 5/8	17 3/4	31	6 1/2
18-33-34	EPB	EPBGMB	EPBGMT		210	130	15	9 1/2	10 1/2	31 3/4	22 5/8	33 5/8	17 3/4	31	6 1/2

Indicate style before model number – EPB, EPBGMT or EPBGMB. Other sizes available.

## Hose Reel Guides



PART NUMBER	DESCRIPTION
9944.0019*	304 SST GM Top Wind Bracket (5 pcs) ~SPEC Model
9944.0041	Roller Body Assy w/Rollers (Less Switch and Switch Bracket) for GM-700
9944.0043	Roller Body Assy w/Rollers & EPS-1 Switch for GM-700
9944.0124	GM-700 Guidemaster Only (w/EPS-1)
9944.0125*	GM-700 w/Top Wind Brackets (w/EPS-1 Switch) ~SPEC Model
9944.0126*	GM-700 w/Bottom Wind Brackets (w/EPS-1 Switch) W/ SPL Assy "B" Rollers ~SPEC Model & Frame Style
9944.0127*	GM-700 w/304 SST Top Wind Brackets (w/EPS-1) ~SPEC Model

## Static Grounding Reels

Safe and reliable for grounding bobbtails and transports



GR75-50

Standard Reel Box  
Economy and Convenience



HGR-50-50

Heavy Duty Reel For Extended Life and Durability

PART NUMBER	TYPE	CABLE		DIMENSION	
		LGTH	DIA	HEIGHT	WIDTH
GR75-20	Standard	20'	3/32"	6"	6 3/4"
GR75-50	Standard	50'	3/32"	7 3/4"	8 3/4"
HGR-50-50	Heavy Duty	50'	1/8"	17 1/2"	14 1/2"
HGR-100-100	Heavy Duty	100'	1/8"	17 1/2"	16 3/4"

## Motors, Sprockets, Chains

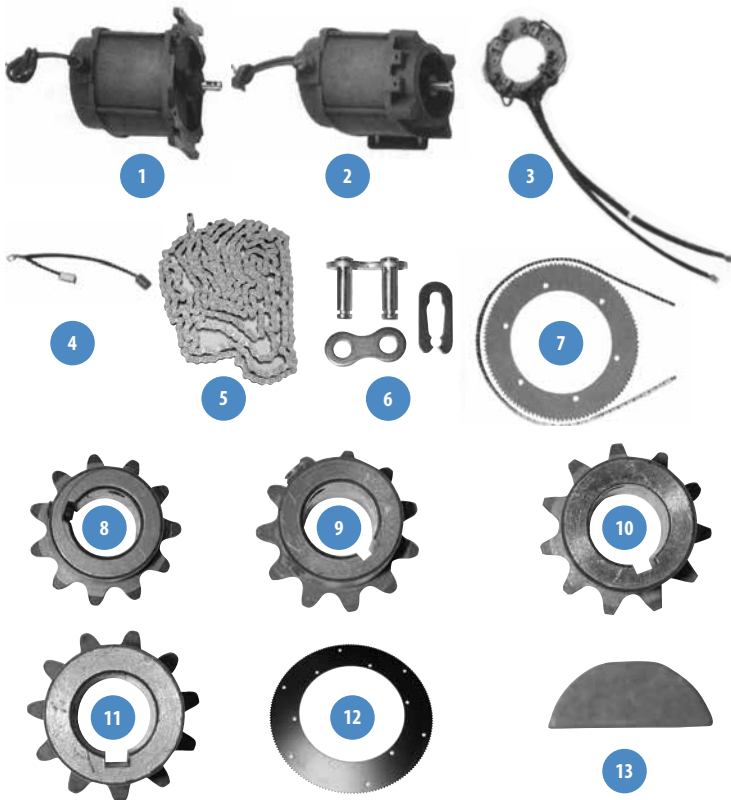

PART NUMBER	DESCRIPTION	PICTURE NUMBER
9915.0003	12 Volt Flange Mount Explosion Proof Motor	1
9915.0013	Short Shaft 12 Volt Base Mount	2
9915.0012	Long Shaft 12 Volt Base Mount	2
9916.0013	Brush Board Assembly (w/springs and brushes) for 12 Volt 1/2 HP Motor	3
9916.007	Two Pairs of Brushes for 12 Volt Explosion Proof Motor (#57200)	4
9912.0001	10' Length #35 Chain w/Connecting Link	5
9912.0002	10' Length #40 Chain w/Connecting Link	5
9912.001	Connecting Link for #35 Chain	6
9910.1423	138T35 Disc Sprocket, 16-5/8" Diameter – Chain Not Included	7
9910.1116	11T35 Motor Sprocket, 3/4" Long	8
9910.1117	11T35 Motor Sprocket, 1 1/16" Long	9
9910.1118	11T35 Motor Sprocket, 1 5/16" Long	10
9910.1119	11T35 Motor Sprocket, 1 3/4" Long	11
9910.1526	Disc Sprocket 21 3/4" Diameter	12
9916.008	3/16 X 3/4 Key for Explosion Proof Motor	13

## Switches and Electrical



PART NUMBER	DESCRIPTION	PICTURE NUMBER
9917.0001	Red Dot EXPB-2A Switch (12 Volt)	1
9917.0014	Red Dot Internal Switch	2
9917.0015	Red Dot Repair Kit	3*
9917.0061	Red Dot 5-Port Round Junction Box/Cover	4*
9917.0062	#6 Wire Nut (For Red Dot Junction Box)	5*
9917.0063	Insulated "Bug" Connector	6*
9917.0025	12 Volt Solenoid (Diode-Suppressed)	7*
specify	SDLM Circuit Breaker (Specify Amperage)	8*
9917.0024	CB-2 Mounting Bracket (for Circuit Breaker)	9*
9917.0006	Push-Button 12 Volt Switch (Less Cap)	10
9917.0008	Rubber Cap (for Push Button Switch)	11*
9917.0200	EPS-1 Switch (used with Guidemaster)	12
9917.0207	EPS-2 Mounting Bracket (use with EPS-1)	13
9917.0208	Extension Bracket for EPS-2	14
9917.0205	Mounting Bracket for GM600 only for EPS1 or 3 switch	15*

\* Not pictured

Also Available: MEP-GM1 Hose Reel Switch Cover



Don't see the Hannay part you need? Give Team Tarantin a call and we'll get it for you.

## Swivels, Risers, Hub Assembly

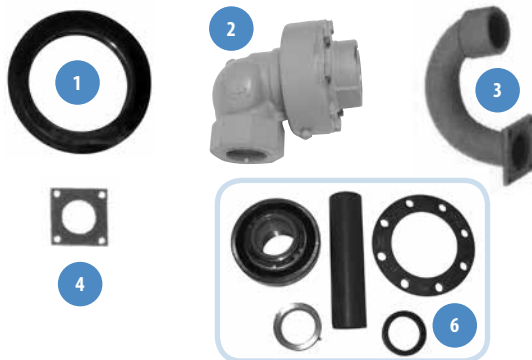

PART NUMBER	DESCRIPTION	PICTURE NUMBER
PK-01	1 1/2" PK-1 BUNA-N Packing (Merkel)	1*
SMAC-112	1 1/2" 900 FXF Full Circle Swivel	2
9901.376	1 1/2" FIPT Iron Flanged Riser	3
9965.0021	H-150G Gasket for 1 1/2" Riser	4
9901.2840	1 1/2" Hub Assy Complete (Specify Model)	5*
SMAC-112-SK	SMAC-112 Repair Kit	6*

\* Not pictured

## Roller Assemblies, Cable Guides, Hose Stops



PART NUMBER	DESCRIPTION	PICTURE NUMBER
specify	Top Wind FH-3 Mtg Brkt. (Specify Model)	1*
9939.0042	FH-3 Roller & Spool Assy (Specify Model)	2
9940.0012	FH-307 Delrin-Over-Steel Step Bolt	3
9940.0004	FH-309 Chrome Snap Cap	4
9940.0005	FH-301 Spool	5
9940.0006	FH-302 Block	6
9940.0007	FH-303-15 (1.5") Trunnion Bearing	7
9940.0008	FH-303-2 (2") Trunnion Bearing	8
9939.0062	Utility Hose Roller Assy "C" (Specify Model)	9*
9940.0076	EH-650 Mounting Block (Plated)	10
9939.0003	EH-714 Roller Assembly	11
9922.0011	HS-3 Hose Stop (Specify OD of Hose)	12
9922.0012	HS-45 Hose Stop (Specify OD of Hose)	13
9940.0016	FH-303 1 1/2" Trunnion Bearing (New Style) (No Through Hole)	14*
9939.0060	Utility Roller Assy (Specify Length)	15
9940.0014	7/16" Nylon Washer for FH Assy	16
9954.0009	7/16" Flat Washer	17

\* Not pictured

## Bearings

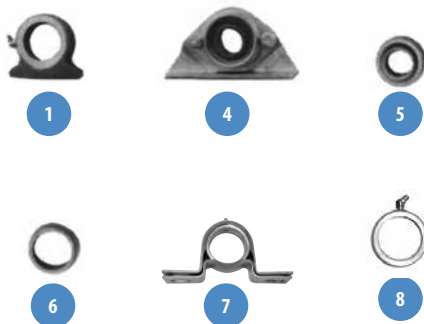

PART NUMBER	DESCRIPTION	PICTURE NUMBER
9902.2100	H-4B Bronze Bearing 1 1/2"	1
9902.1200	1/2" S.A. Ball Bearing Complete	2*
9902.1300	1/2" S.A. Ball Bearing Insert	3*
9902.1400	1" S.A. Ball Bearing Complete	4
9902.1500	1" S.A. Ball Bearing Insert	5
9902.16100	1 1/2" S.A. Bronze Bearing Complete (E Coated)	6
9902.16200	1 1/2" S.A. Bronze Bearing Complete (304SS)	7
9902.1700	1 1/2" S.A. Bronze Bearing Complete Insert	8*
9902.17300	1" S.A. Bronze Bearing Insert	9*

\* Not pictured

## Rewind Assemblies, Brakes, Ratchets

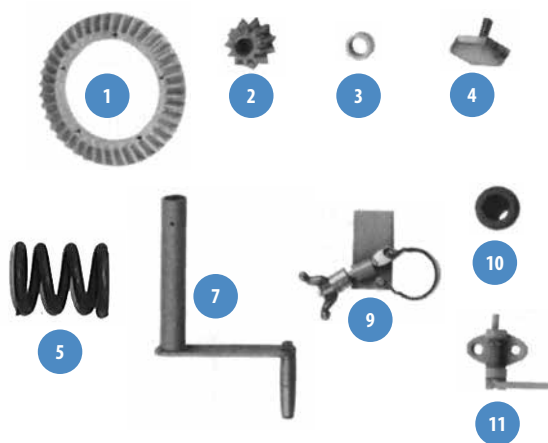

PART NUMBER	DESCRIPTION	PICTURE NUMBER
9914.0372	H-26 Ring Gear	1
9914.0393	H-27 Pinion Gear	2
9914.0351	Pinion Shaft Collar	3
9914.0413	H-30A Brake Wheel	4
9914.0451	H-31 Brake Spring	5*
9914.0433	H-3 Brake Pad	6*
9914.0011	H-18 Hand Crank	7
9947.0001	Manual Caliper Brake	8*
9947.0035	Comet Brake Assembly (IV Style)	9
9947.0038	Comet Brake IronHub (IV Style)	10
9965.003	PL-1 Pinlock	11

\* Not pictured

## Guidemaster Parts and Brackets

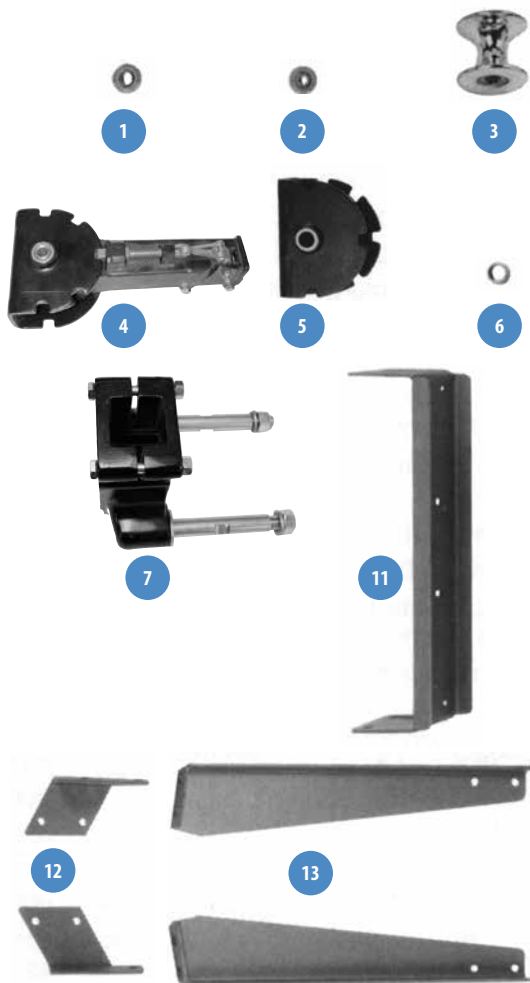

PART NUMBER	DESCRIPTION	PICTURE NUMBER
9945.0026	GM Ball Bearing (For GM Roller)	1
9945.0044	GM-108 Ball Bearing (for GM-109 Roller)	2
9945.0019	GM Roller w/GM Bearing	3
9944.0040	GM-700 Guide Arm Body Assy w/mtg Yoke	4
9945.0009	GM Mounting Yoke w/Bronze Bushing	5
9945.0011	GM Oil-Impregnated Bronze Bushing	6
9945.1001	GM Roller Body w/Mtg Bolts	7
9945.1005	GM Roller Mtg. Bolts	8*
9945.1003	Pinlock assy GM 700	9*
9945.1004	GM Roller Bolt Mounting Plate	10*
9945.0035	GM Cross Member Assembly (3 Pieces) (Specify Model)	11
9945.0036	GM Bottom Wind Brackets (Pair)	12
9945.0037	GM Top Wind Brackets (Pair)	13
9939.0069	Assy. "B" Roller for Bottom Wind Guidemaster Reels (Specify Model)	14
9945.0024	Pivot Pin	15

\* Not pictured

Note: Some parts for GM-600 Guidemaster are still available



*We're your headquarters  
for forged steel fittings and  
schedule 80 nipples.*

## Schedule 80 Forged Steel Reducing Fittings – Threaded

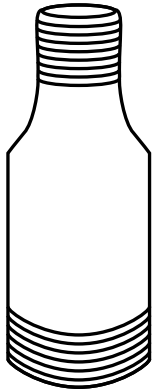

Swage Nipple

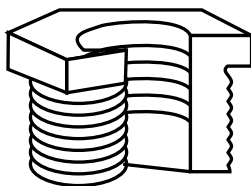

Hexagon Bushing

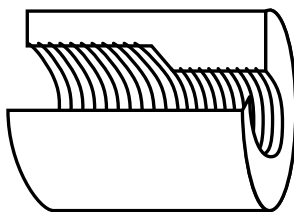

Reducer

MPT X FPT- NOMINAL PIPE SIZE	CONCENTRIC SWAGE NIPPLES SCHEDULE 80	HEX BUSHINGS 3000#	REDUCER COUPLINGS 3000#	ECCENTRIC SWAGE NIPPLES SCHEDULE 80
3/8 x 1/8	-	-	600600	-
3/8 x 1/4	-	603120	600601	-
1/2 x 1/4	-	603135	600603	-
1/2 x 3/8	-	603318	600604	-
3/4 x 1/4	-	603125	600605	-
3/4 x 3/8	620019	603122	-	-
3/4 x 1/2	620020	603145	600609	-
1 x 1/4	-	603155	600611	-
1 x 3/8	-	603160	-	-
1 x 1/2	620025	603165	600613	-
1 x 3/4	620030	603170	600614	-
1 1/4 x 3/8	-	603193	-	-
1 1/4 x 1/2	620035	603190	60019	-
1 1/4 x 3/4	620040	603195	600619	-
1 1/4 x 1	620045	603200	600620	620045E
1 1/2 x 3/4	-	603225	-	-
1 1/2 x 1	620050	603230	600626	620050E
1 1/2 x 1 1/4	620055	603235	600627	620055E
2 x 1/4	-	603250	-	-
2 x 3/8	-	603254	-	-
2 x 1/2	620059	603255	600631	-
2 x 3/4	620060	603260	600632	-
2 x 1	620065	603265	600633	-
2 x 1 1/4	620070	603270	600634	-
2 x 1 1/2	620075	603275	600635	620075E
2 1/2 x 1 1/2	620077	603318	600640	-
2 1/2 x 2	620080	603320	-	-
3 x 3/4	-	603360	-	-
3 x 1	620090	-	-	-
3 x 1 1/2	620085	603363	-	-
3 x 2	620100	603365	600653	-
3 x 2 1/2	620095	-	-	-

*Other Sizes Available*



## Schedule 80 Forged Steel Fittings – Threaded



45° Elbow



90° Elbow



90° Street Elbow



Coupling



Cross



Tee



Hex Head Plug



Union

ITEM	PRESSURE	NORMAL PIPE SIZE									
		1/4	3/8	1/2	3/4	1	1 1/4	1 1/2	2	2 1/2	3
90° Elbow	2000#	611070	611071	611014	611019	611024	611029	611034	611039	611044	611049
45° Elbow	2000#	611104	611079	611115	611080	611081	611129	611134	611139	611141	611145
Tees	2000#	611168	611169	611170	611171	611173	611174	611176	611175	611177	611180
Crosses	2000#	611510	611511	611512	611516	611524	611531	611532	611533	611534	611535
90° Street Elbow	3000#	611160	611159	611162	611163	611164	611165	611166	611167	611158	611157
Couplings	3000#	600105	600110	600115	600120	600125	600130	600135	600140	600145	600150
Hex Head Plugs	3000#	600505	600510	600515	600520	600525	600530	600535	600540	600545	600550
Unions	3000#	660105	660110	660115	660120	660125	660130	660135	660140	660145	660150
Caps	3000#	600005	600010	600015	600020	600025	600030	600035	600040	600045	600050

## Schedule 80 Forged Steel Fittings – Socket Weld

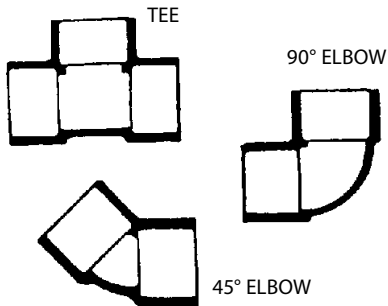

ITEM	PRESSURE	PIPE SIZE			
		1	1 1/4	1 1/2	2
45° Elbow	3000#	1-45SW	1 1/4-45SW	1 1/2-45SW	2-45SW
90° Elbow	3000#	1-90SW	1 1/4-90SW	1 1/2-90SW	2-90SW
Tee	3000#	1-T-SW	1 1/4-T-SW	1 1/2-T-SW	2-T-SW
Union	3000#	1-UNSW	1 1/4-UNSW	1 1/2-UNSW	2-UNSW
Cap	3000#	1-CAP-SW	1 1/4-CAP-SW	1 1/2-CAP-SW	2-CAP-SW
Reducing Insert	3000#	-	-	-	2X1 1/4SW-IS
	3000#	-	-	-	2X1 1/2SW-IS

*Other Sizes Available*



**Sure we've got schedule 40 nipples and malleable fittings. See page 173.**

## Schedule 80 Nipples



612009



612216



612410

ITEM	TYPE	NORMAL PIPE SIZE									
		1/4	3/8	1/2	3/4	1	1 1/4	1 1/2	2	2 1/2	3
Nipple Close	SCH 80	612019	612020	612040	612095	612170	612220	612285	612335	612403	612405
1 1/2" Nipple	SCH 80	612008-2	-	-	612100	-	-	-	-	-	-
2" Nipple	SCH 80	612009	612024	612050	612105	612175	612225	612289	-	-	-
2 1/2" Nipple	SCH 80	612009-2	-	612050-2	612110	612180	612225-2	612289-2	612336-2	-	-
3" Nipple	SCH 80	612011	612026	612060	612115	612185	612235	612295	612350	614266	612408
3 1/2" Nipple	SCH 80	612011-2	612026-2	612065	612115-2	612190	612240	612300	612355	-	-
4" Nipple	SCH 80	612014	612027	612070	612125	612195	612245	612305	612360	612467	612410
4 1/2" Nipple	SCH 80	-	-	612075	612125-2	-	612245-2	612310	612360-2	-	-
5" Nipple	SCH 80	612017	612028	612080	612135	612205	612255	612315	612375	612468	612420
5 1/2" Nipple	SCH 80	-	-	612080-2	612135-2	-	612255-2	-	612-375-2	-	-
6" Nipple	SCH 80	612018	612029	612090	612145	612215	612265	612325	612385	612469	612430
7" Nipple	SCH 80	-	-	-	-	-	-	-	-	-	-
8" Nipple	SCH 80	-	-	-	612150	612216	612270	-	612395	-	612450
9" Nipple	SCH 80	-	-	-	612151	-	-	612330	-	-	-
10" Nipple	SCH 80	-	-	-	-	-	612271	-	612387	-	-
11" Nipple	SCH 80	-	-	-	-	-	-	-	-	-	-
12" Nipple	SCH 80	-	612035	-	612155	612275	612272	612333	612390	-	612454

*Other Sizes Available Upon Request*



### Fittings - Galvanized

ITEM	PIPE SIZE									
	1/8	1/4	3/8	1/2	3/4	3/8	1	1 1/4	1 1/2	2
90° Elbow	44007	44008	44009	44010	44012	-	44013	-	44016	-
90° Elbow - Domestic	-	-	-	44010-DOM	44012-DOM	-	44013-DOM	-	-	-
90° Street Elbow	-	44032	-	44035	44036	44034	44037	-	-	-
90° Street Elbow - Domestic	-	-	-	44035-DOM	44036-DOM	-	-	-	-	-
45° Elbow	-	-	-	44025	44026	44041	44027	-	-	-
45° Street Elbow	-	-	-	44033	-	-	44038	-	-	-
Caps	44061	44062	44069	44070	44071	-	44072	-	-	44076
Caps - Domestic	-	-	-	44070-DOM	44071-DOM	-	-	-	-	-
Couplings	-	44081	44084	44085	44086	-	44087	-	-	-
Couplings - Domestic	-	-	-	44085-DOM	44086-DOM	-	-	-	-	-
Couplings - Merchant	-	-	-	46017	46018	46016	46019	-	-	-
Crosses	-	-	-	44120	44121	-	44122	-	-	-
Floor Flange	-	-	-	44116	44117	-	44118	-	-	-
Hex Head	-	44115	-	44110	44111	44109	44112	-	-	-
Hex Head - Domestic	-	-	-	44110-DOM	44111-DOM	-	-	-	-	-
Tees	44042	44043	-	44050	44051	-	44052	44044	44045	44046
Tees - Domestic	-	-	-	44050-DOM	44051-DOM	-	44052-DOM	-	-	-
Unions	-	-	44125	44126	44127	-	44128	-	-	44131
Unions - Domestic	-	-	-	44126-DOM	44127-DOM	-	44128-DOM	-	-	-

### Reducing Fittings - Galvanized

ITEM	PIPE SIZE															
	1/4 X 1/8	3/8 X 1/4	3/8 X 1/2	1/2 X 1/8	1/2 X 1/4	1/2 X 3/8	3/4 X 1/4	3/4 X 3/8	3/4 X 1/2	1 X 1/2	1 X 3/8	1 X 3/4	1 1/4 X 3/4	1 1/2 X 3/4	1 1/2 X 1	2 X 1 1/2
Bushing	-	44104	-	44101	44100	44099	44106	44138	44097	44113	44108	44098	-	44546	44547	-
Coupling	44082	44083	44090	-	44088	44089	-	-	44095	44095-2	-	44096	44094	-	-	44091
Hex Bushing - Domestic	-	-	-	-	-	-	-	-	44097-DOM	-	-	44098-DOM	-	-	-	-
Reducer - Domestic	-	-	-	-	-	-	-	-	44095-DOM	-	-	-	-	-	-	-
90° Elbow	-	-	-	-	-	44018	-	-	44014	-	-	44015	-	-	-	-
Tee	-	-	-	-	-	-	-	-	44048	-	-	44053	-	-	-	-

## 300 Lb Forged Steel Flanges

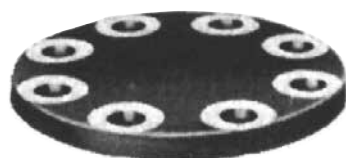

Blind Flange



Slip-On Flange



Weld Neck Flange

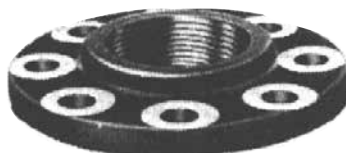

Screwed Flange

### Flange Nuts, Bolts and Studs

High grade flange nuts, bolts and studs are available in 3" to 6" sizes.

TYPE	SIZE		
	2"	3"	4"
BLIND	F-2B	F-3B	F-4B
SLIP-ON	F-2	F-3	F-4
WELD NECK	F-2WN	F-3WN	F-4WN
THREAD	F-2T	F-3T	F-4T

*Other Sizes Available Upon Request*

## Flexitallic Style CG Gaskets



Gaskets

PART NUMBER	PIPE SIZE	ID	OD	CLASS
CG-3F	1 1/2	2 1/8	3 3/4	300LB
CG-3G	2	2 3/4	4 3/8	300LB
CG-3J	3	4	5 7/8	300LB
CG-3L	4	5	7 1/8	300LB
CG-3P	6	7 3/16	9 7/8	300LB
CG-1T	14	14 5/8	17 3/4	150LB
CG-1U	16	16 5/8	20 1/4	150LB
CG-1V	18	18 11/16	21 5/8	150LB
CG-1W	20	20 11/16	23 7/8	150LB

*Other Sizes Available*

## Flange Insulation Sets

For use in commercial, industrial, or plant applications where underground piping needs to be isolated from the tanks or the building.  
Available 2" thru 8", 150 and 300 pound.  
Part Number: ENSW-(size)



*Make your serviceman's job a little easier with our drip leg kits and nipple assortments*

## 150LB Malleable Fittings for Schedule 40 Pipe



Tee



90° Elbow

ITEM	PIPE SIZE					
	3/8"	1/2"	3/4"	1"	1 1/4"	2"
90° Elbow	45009	45010	45012	45013	-	-
45° Elbow	45041	45025	45026	45027	-	-
Tees	45049	45050	45051	45052	-	-
90° Street Elbow	45034	45035	45036	45037	-	-
Coupling	45084	45085	45086	45087	-	-
Cap	45069	45070	45071	45072	-	-
Plug SQ Head	45109	45110	45111	45112	-	-
Union	45125	45126	45127	45128	-	-
Close Nipple	45407	45200	45226	45250	45270	45282
1 1/2 Nipple	-	45201	45227	45250-2	-	-
2 Nipple	45409	45202	45228	45251	45275	-
2 1/2 Nipple	-	45203	45229	45251-2	45272	45284
3 Nipple	45410	45204	45230	45252	45276	45285
3 1/2 Nipple	-	45205	45231	45252-2	45277	45286
4 Nipple	45411	45206	45232	45253	45256	45287
4 1/2 Nipple	-	45207	45233	45253-2	45279	45288
5 Nipple	45412	45208	45234	45254	45280	45289
5 1/2 Nipple	-	45209	45235	45254-2	45281	45290
6 Nipple	45413	45210	45236	45255	45278	45291
8 Nipple	-	45211	45237	-	-	-
10 Nipple	-	45216	45417	-	45273	45283
12 Nipple	-	45225	45245	45264	45274	45292

## Reducing Fittings

PIPE SIZE	BUSHING	REDUCER COUPLING
1/2 x 1/4	45100	-
1/2 x 3/8	45099	45091
3/4 x 3/8	45138	45092
3/4 x 1/2	45097	45095
1 x 1/2	-	45095-2
1 x 3/4	45098	45096
1 1/4 x 1/2	-	45093
1 1/4 x 3/4	-	45094

Note: 150# malleable for use with schedule 40 pipe.



**We carry only forged flare nuts for you and your customers' safety.**

## Standard Sediment Traps

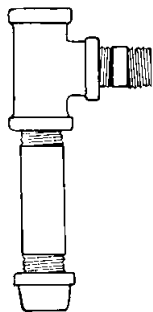

Tee, nipples and cap packaged in zip lock bag.

PART NUMBER	SIZE
DRIP-LEG 3/8	3/8"
DRIP-LEG 1/2	1/2"
DRIP-LEG 3/4	3/4"

Note: Schedule 40 nipples with 150# malleable fitting.

## Dielectric Union



SIZE	150 LB WORKING PRESSURE VAPOR LINES	3000 LB WORKING PRESSURE LIQUID LINES	250 PSI
1/2"	1V-150-012	IU-3000-012	701-403
3/4"	1V-150-034	IU-3000-034	701-404
1"	1V-150-100	IU-3000-100	701-405
1 1/4"	1V-150-114	IU-3000-114	701-406
1 1/2"	-	IU-3000-112	701-407
2"	1V-150-200	IU-3000-200	701-408
3/4" x 3/8"	-	-	704-102
3/4" x 1/2"	-	-	704-103
3/4" x 5/8"	-	-	704-104

## Nipple Trays/Dividers – All Steel

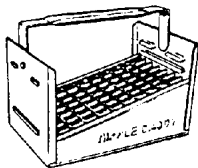

Nipple Tray

PART NUMBER	DESCRIPTION	DIMENSIONS
A3500F	1/2" Nipple Tray - Holds 77 Nipples	11" x 7 3/4" x 6 3/4"
A3501K	3/4" Nipple Tray - Holds 66 Nipples	12 3/4" x 7 3/4" x 6 3/4"

## Filter Flare

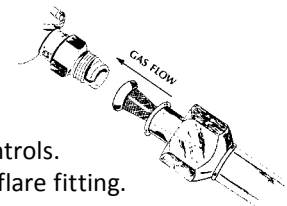

Traps sediment before entering regulators and controls. Fits into common flare fitting.

PART NUMBER	DESCRIPTION
72FF-06	3/8" Flare Filter
72FF-08	1/2" Flare Filter
72FF-10	5/8" Flare Filter

## Plastic Threaded Plug

Plastic plugs for cylinders without valves.



T-Series

PART NUMBER	DESCRIPTION
R1/2	1/2 NPT
R3/4	3/4 NPT
R1	1 NPT
T-6	3/8 M. Flare
T-7	1/2 M. Flare
T-8	5/8 M. Flare

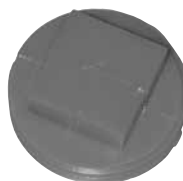

R-Series

## Nipple Kits

### 66 Assorted Nipples per Kit

6 each of close, 1 1/2, 2, 2 1/2, 3, 3 1/2, 4, 4 1/2, 5, 5 1/2, and 6.

PART NUMBER	DESCRIPTION	PIPE TYPE
BLK66F	1/2" close-6"	Schedule 40
BLK66K	3/4" close-6"	Schedule 40
GALV66F	1/2" close-6"	Galvanize
GALV66K	3/4" close-6"	Galvanize

## 2 Hole Pipe Strap Hanger

PART NUMBER	DESCRIPTION
G440-08	1/2"
G440-12	3/4"
G440-16	1"

## Fittings

### NS4 Forged Flare Nut



PART NUMBER	O.D. TUBE SIZE
NS4C	1/4"
NS4E	3/8"
NS4F	1/2"
NS4I	5/8"
NS4K	3/4"

### Full Union No. 42



PART NUMBER	O.D. TUBE SIZE
42C	1/4"
42E	3/8"
42F	1/2"
42I	5/8"

### 44 3 Way Reducing Tee



PART NUMBER	O.D. TUBE SIZE		
	1	2	3
44EEC	3/8"	3/8"	1/4"
44FFE	1/2"	1/2"	3/8"
44FEF	1/2"	3/8"	1/2"
44FFE	1/2"	1/2"	3/8"
44FFI	1/2"	1/2"	5/8"
44IIE	5/8"	5/8"	3/8"
44IIF	5/8"	5/8"	1/2"
44EEF	3/8"	3/8"	1/2"

### NRS4 Forged Reducing Flare Nut



PART NUMBER	O.D. TUBE SIZE
NRS4FE	1/2" x 3/8"
NRS4IE	5/8" x 3/8"
NRS4IF	5/8" x 1/2"

### Reducing Union No. 42



PART NUMBER	O.D. TUBE SIZE
42EC	3/8" x 1/4"
42FE	1/2" x 3/8"
42IE	5/8" x 3/8"
42IF	5/8" x 1/2"

### 44 Forged 3 Way Tee



PART NUMBER	O.D. TUBE SIZE
44C	1/4"
44E	3/8"
44F	1/2"
44I	5/8"

### US4 Swivel Nuts



PART NUMBER	O.D. TUBE SIZE
US4C	1/4"
US4E	3/8"
US4F	1/2"
US4I	5/8"
US4K	3/4"
US4EC	3/8" x 1/4"
US4FE	1/2" x 3/8"
US4IF	5/8" x 1/2"

### No. 45 Flare Tee x Male IPT on Branch



PART NUMBER	O.D. TUBE X IPS
45EEE	3/8" x 3/8" x 3/8"
45EEF	3/8" x 3/8" x 1/2"
45FFE	1/2" x 1/2" x 3/8"
45FFF	1/2" x 1/2" x 1/2"
45IIF	5/8" x 5/8" x 5/8"

### No. 47 Flare x Male 45° Elbow



PART NUMBER	O.D. TUBE X IPS
47EC	3/8" x 1/4"
47EE	3/8" x 1/2"
47EF	3/8" x 1/2"
47FE	1/2" x 3/8"
47FF	1/2" x 1/2"

### No. 46 Flare x Female IPT Connector



PART NUMBER	O.D. TUBE SIZE X IPS
46CC	1/4" x 1/4"
46EA	3/8" x 1/8"
46EC	3/8" x 1/4"
46EE	3/8" x 3/8"
46EF	3/8" x 1/2"
46EK	3/8" x 3/4"
46FC	1/2" x 1/4"
46FE	1/2" x 3/8"
46FF	1/2" x 1/2"
46FK	1/2" x 3/4"
46IE	5/8" x 3/8"
46IF	5/8" x 1/2"
46IK	5/8" x 3/4"

### No. 55 Full Flare Elbow



PART NUMBER	O.D. TUBE SIZE
55C	1/4"
55E	3/8"
55F	1/2"
55I	5/8"
55K	3/4"
55EC	3/8" x 1/4"
55FE	1/2" x 3/8"
55IF	5/8" x 1/2"

### No. 54 Flare x Female Elbow



PART NUMBER	O.D. TUBE SIZE X IPS
54EC	3/8" x 1/4"
54EE	3/8" x 3/8"
54EF	3/8" x 1/2"
54EK	3/8" x 3/4"
54FC	1/2" x 1/4"
54FE	1/2" x 3/8"
54FF	1/2" x 1/2"
54FK	1/2" x 3/4"
54IE	5/8" x 3/8"
54IF	5/8" x 1/2"
54IK	5/8" x 3/4"

### SAE Copper Seal Bonnet



PART NUMBER	O.D. TUBE X IPS	LINE SIZE
B1C	1/4"	3/8"
B1E	3/8"	1/2"
B1F	1/2"	5/8"
B1I	5/8"	3/4"



Each year Tarantin puts on dozens of schools. Pumps, meters, regulators, heaters, plastic pipe, CSST or you name it; our people have the know-how.

## Fittings

### No.49 Flare x Male Elbow



PART NUMBER	O.D. TUBE SIZE X IPS
49CA	1/4" x 1/8"
49CC	1/4" x 1/4"
49CE	1/4" x 3/8"
49CF	1/4" x 1/2"
49EA	3/8" x 1/8"
49EC	3/8" x 1/4"
49EE	3/8" x 3/8"
49EF	3/8" x 1/2"
49EK	3/8" x 3/4"
49FC	1/2" x 1/4"
49FE	1/2" x 3/8"
49FF	1/2" x 1/2"
49FK	1/2" x 3/4"
49IC	5/8" x 1/4"
49IE	5/8" x 3/8"
49IF	5/8" x 1/2"
49IK	5/8" x 3/4"
49KE	3/4" x 3/8"
49KF	3/4" x 1/2"
49KK	3/4" x 3/4"

### No. 48 Flare x Male IPT Connector

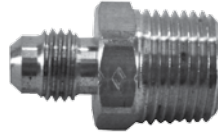

PART NUMBER	O.D. TUBE SIZE X IPS
48CA	1/4" x 1/8"
48CC	1/4" x 1/4"
48CE	1/4" x 3/8"
48CF	1/4" x 1/2"
48EA	3/8" x 1/8"
48EC	3/8" x 1/4"
48EE	3/8" x 3/8"
48EF	3/8" x 1/2"
48EK	3/8" x 3/4"
48FC	1/2" x 1/4"
48FE	1/2" x 3/8"
48FF	1/2" x 1/2"
48FK	1/2" x 3/4"
48IE	5/8" x 3/8"
48IF	5/8" x 1/2"
48IK	5/8" x 3/4"
48KF	3/4" x 1/2"
48KK	3/4" x 3/4"

### No. 48 Flare x Male Connector - Long Shank



PART NUMBER	O.D. TUBE SIZE X IPS
48F-6-6LS	3/8" x 3/8"
48F-6-8LS	3/8" x 1/2"
48F-8-6LS	1/2" x 3/8"
48F-8-8LS	1/2" x 1/2"

### Full Flare Cross Reducing



PART NUMBER	O.D. TUBE SIZE
C1E	3/8"
C1F	1/2"
C1I	5/8"

### Plastic Flare Plug

Dirt Seal Only  
Do Not Use Under Pressure



PART NUMBER	FLARE
T-6	3/8"
T-7	1/2"
T-8	5/8"

### Brass Flare Plug



PART NUMBER	O.D. TUBE SIZE
P2C	1/4"
P2E	3/8"
P2F	1/2"
P2I	5/8"

### Flare Cap



PART NUMBER	O.D. TUBE SIZE
N5C	1/4"
N5E	3/8"
N5F	1/2"
N5I	5/8"

### Male Flare X POL Adapter



PART NUMBER	SIZE
BG20E	POL x 3/8" M Flare
BG20F	POL x 1/2" M Flare
BG20I	POL x 5/8" M Flare

### POL-Fittings



PART NUMBER	MATERIAL	DESCRIPTION
737-5	Plastic	Plug
G-1691	Brass	Plug
G-1699	Brass	Cap



## Coated Copper Tubing



Copper has proven to be reliable and economical for propane installations for over 30 years. Now take the next step toward safer installations.

Advantages of coated copper tubing:

- Line marked for identification
- Marked for easy measuring
- Easy installation (labor savings)
- Flexible
- Fewer joints/fittings
- One person installation
- Minimal inventory space required
- No power needed to install

### EASY TO IDENTIFY

- Permanent yellow polyethylene coating
- Continuous line marking
- Traceable back to origin of manufacturing
- Mill test reports available upon request

### EASY TO INSTALL

- No additional training required for installation
- Flexible • Easy to join • Compact size
- Requires smaller and fewer tools than steel pipe
- Cleaner than threaded steel pipe

### COST EFFICIENT

- Most economical line-marked tubing on the market
- Minimal labor costs due to quick and easy installation
- No on-site sleeving required for underground gas lines

### RECYCLABLE

- Copper is fully recyclable

Refrigeration (O.D.) Coated Copper Application Low Pressure	
PART NUMBER	DESCRIPTION
CCR-3/8X50	3/8" x 50FT
CCR-3/8X100	3/8" x 100FT
CCR-1/2X50	1/2" x 50FT
CCR-1/2X100	1/2" x 100FT
CCR-5/8X50	5/8" x 50FT
CCR-5/8X100	5/8" x 100FT

TYPE L (I.D.) Coated Copper Application High Pressure (UG)	
PART NUMBER	DESCRIPTION
CCL-1/4X60	1/4" x 60FT
CCL-3/8X60	3/8" x 60FT
CCL-3/8X100	3/8" x 100FT
CCL-1/2X60	1/2" x 60FT
CCL-1/2X100	1/2" x 100FT
CCL-5/8X60	5/8" x 60FT

J Clips for Copper Tubing



PART NUMBER	DESCRIPTION
MSCP-#1-J-CLIP	Copper J clip for 3/8" & 1/2" OD
MSCP-#2-J-CLIP	Copper J clip for 5/8" OD

Tube Talon Holder



PART NUMBER	O.D. TUBE SIZE
555-1	3/8" for 1/2" Copper Tubing
555-2	1/2" for 5/8" Copper Tubing
555-3	1/2" for 1/2" CSST



However you need to get there – copper, coated copper, CSST or polyethylene pipe – we've got it for you.

## Copper Tubing



### Copper Refrigeration Tubing

For second stage pressure and indoor applications only. Measured in Outside Diameter (O.D.)

PART NUMBER		O.D.	I.D.	WALL
50 FT COIL	100 FT COIL			
REF-1/8-50	REF-1/8-100	1/8"	-	-
REF-1/4-50	REF-1/4-100	1/4"	-	-
REF-3/8-50	REF-3/8-100	3/8"	1/4"	0.032
REF-1/2-50	REF-1/2-100	1/2"	3/8"	0.032
REF-5/8-50	REG-5/8-100	5/8"	1/2"	0.035
REF-3/4-50	REF-3/4-100	3/4"	-	-

### Copper Tubing Shields

Flexible plastic coated conduit protects the copper tubing at tank and service end of installation.

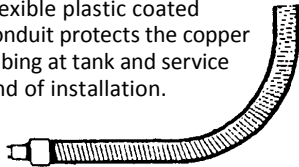

PART NUMBER	DESCRIPTION
31490	36" Copper Tubing Protection Shield

### Copper Type L Tubing

First and second stage use, good for indoor and external installation. Measured in Inside Diameter (I.D.)

PART NUMBER		I.D.	O.D.	WALL
60 FT COIL	100 FT COIL			
TYL-1/4-60	TYL-1/4-100	1/4"	3/8"	0.03
TYL-3/8-60	TYL-3/8-100	3/8"	1/2"	0.035
TYL-1/2-60	TYL-1/2-100	1/2"	5/8"	0.04

### Copper Type K Tubing

For all pressure including tank. Can be installed underground. For liquid applications. Measured in Inside Diameter (I.D.)

PART NUMBER		I.D.	O.D.	WALL
60 FT COIL	100 FT COIL			
TYK-1/4-60	TYK-1/4-100	1/4"	3/8"	0.035
TYK-3/8-60	TYK-3/8-100	3/8"	1/2"	0.049
TYK-1/2-60	TYK-1/2-100	1/2"	5/8"	0.049

## Termination Flange



The Copper Stopper termination flange transitions the copper tube back to standard pipe, reducing the amount of tubing required for a job and protecting the line from damage.

Part Number: 71900

## Aluminum Tubing for Pilot Lines



1/4" OD Type Alum x 50' Coil

Part Number: ALUM-1/4-50

Compression Fittings available upon request. Please call for more information.

**Polyethylene Pipe**



Polyethylene Pipe is a safe, economical system of running underground gas line that has been approved since 1979. Plastic Gas Pipe can be joined using mechanical fittings, butt fusion, socket fusion, sidewall fusion or electrofusion and should not be used with pressures exceeding 30 PSI. Pipe is manufactured and rated according to the following guidelines ASTM D 2513, ASTM F 678, ASTM D 3350, ASTM D 1248.

TUBING (CTS) PART NUMBER	SIZE-IN	SDR	OD	ID	MIN WALL THICK	APPROX WEIGHT - LBS/100	COIL OR JOINT LENGTH AVAILABLE
PP-1/2CTS	1/2" 5/8" OD	7	0.625	0.44	0.09	6.5	250'/500'
PP-1CTS	1" 1 1/8" OD	11.5	1.125	0.94	0.099	13.8	250'/500'
PIPE (IPS) PART NUMBER	SIZE-IN	SDR	OD	ID	MIN WALL THICK	APPROX WEIGHT - LBS/100	COIL OR JOINT LENGTH
PP-1/2IPS	1/2"	9.33	0.84	0.683	0.09	9	500'
PP-3/4IPS	3/4"	11	1.05	0.854	0.095	12.4	150'/250'/500'
PP-1IPS	1"	11	1.315	1.068	0.12	19.4	250'/500'
PP-1 1/4IPS	1 1/4"	10	1.66	1.349	0.166	34	250'/500'
PP-1-1/2IPS	1 1/2"	11	-	-	-	38.5	150'/500'
PP-2IPS	2"	11	2.375	1.93	0.216	63	150'/250'/500'
PP-3IPS-40	3"	11	3.5	2.845	0.318	138	40'
PP-4IPS	4"	11	4.5	3.752	0.409	228	40'

**Electrofusion Systems**



Friarmatt connects to computer, allowing for direct data transfer. Easy to operate and transport.



**Training Available**

Couplings have wide fusion zones and can be re-fused in case of electrical power interruption. The widest range of sizes available.

*Call for more information on Electrofusion Systems.*

## LP Gas Vapor Line Sizing for Polyethylene Tubing

Sizing for vapor between 1st and 2nd stage regulators allowing a pressure drop of 1 PSI at 10 PSI setting.

TUBING LENGTH (FT)*	1/2" CTS SDR 7 (.090")	1/2" IPS SDR 9.3 (.090")	3/4" IPS SDR 11 (.095")	1" CTS SDR 11.5 (.099")	1" IPS SDR 11 (.119")	1 1/4" IPS SDR 10 (.166")	2" IPS SDR 11 1(.216")
10	1406	4235	8940	10803	16486	28912	82488
20	944	2842	6001	7252	11067	19409	55373
30	747	2252	4753	5744	8766	15372	43858
40	634	1908	4029	4868	7429	13029	37171
50	557	1679	3544	4282	6535	11460	32695
60	502	1512	3191	3856	5884	10319	29441
70	459	1383	2920	3529	5385	9444	26944
80	425	1281	2704	3268	4987	8746	24953
90	397	1197	2527	3054	4661	8173	23319
100	374	1127	2379	2874	4387	7693	21948
125	329	991	2092	2528	3858	6766	19305
150	296	893	1884	2277	3474	6093	17384
175	271	817	1724	2084	3180	5576	15909
200	251	756	1597	1930	2945	5164	14733
225	235	707	1492	1803	2752	4826	13768
250	221	665	1405	1697	2590	4542	12959
275	209	630	1330	1607	2452	4300	12268
300	199	599	1265	1528	2332	4090	11669
350	182	548	1157	1399	2134	3743	10680
400	169	508	1072	1295	1976	3467	9890

\* Note: The above numbers were calculated by using the Mueller formula (Mueller Co. - Decatur, IL) for high pressure installations of smooth pipe such as plastic, copper, brass, etc. carrying gas at pressures greater than 1 psig.

## Easy-to-install Permasert System



1

Cut the tubing so that the end is square.



2

Wipe with a clean dry cloth. Inspect for scratches or gouges. If any, cut again

so that the last 2 to 6 inch section, depending on size, has no surface defects.



3

Use the Perfection Chamfering Tool for a proper O.D. chamfer. This chamfer

permits the tubing to be completely stabbed without affecting the internal seals.



4

Use a soft felt-tip pen, crayon or grease pencil to mark the stab depth as indicated on your Permasert package instructions. The stab depth is the

approximate distance from the edge of the fusion bead to the end of the fitting body.



5

Stab the tubing into the Permasert fitting so that the stab depth mark is visible within 1/8" of the end of the fitting on 1/2" and 1" CTS sizes, within 1/4" on all other sizes through 1 1/4" CTS, and approximately 3/8" on the 1 1/4" and 2" IPS sizes. The tubing must

bottom out in the fitting. Pressure test the joint in accordance with your standard procedures. The reference mark can move outward up to an additional 3/8" during pressure testing.

## Plastic Mechanical Fittings

### Permasert Mechanical Couplings



SIZE-IN.	PART NUMBER
1/2" CTS	50100
1/2" IPS	50701
3/4" IPS	50030
1" CTS	50103
1" IPS	50601
1 1/4" IPS	50035010
1 1/2" IPS	50361
2" IPS	50314

### Permasert Reducing Couplings



SIZE	PART NUMBER
3/4" IPS x 1" CTS	50146
1/2" IPS x 1" CTS	50755
1/2" IPS x 3/4" IPS	50756
1/2" IPS x 1" IPS	50621
1/2" CTS x 1" CTS	50149
1/2" CTS x 3/4" IPS	50969
1/2" CTS x 1" IPS	50641
3/4" IPS x 1" CTS	50148
1" CTS x 1 1/4" IPS	50192
1" IPS x 3/4" IPS	51432
1" IPS x 1" CTS	50623
1/2" IPS x 1/2" CTS	50751
1 1/4" IPS x 3/4" IPS	51677
1 1/4" IPS x 1" IPS	50343010
1 1/4" IPS x 2" IPS	50333010

### Permasert Repair Couplings



SIZE	LENGTH	PART NUMBER
1/2" CTS	12"	50056
1/2" CTS	24"	50177
1/2" IPS	12"	50740
3/4" IPS	12"	50175
3/4" IPS	24"	50067030
1" CTS	12"	50172
1" IPS	12"	50640
1 1/4" IPS	13"	50320100
1 1/4" IPS	24"	50332
2" IPS	15"	50341

### Plastic to Copper Transitions



SIZE	PART NUMBER
1/2" CTS x 3/8" FLARE	41007
1/2" CTS x 1/2" FLARE	41013
1/2" IPS x 1/2" FLARE	41140
1/2" CTS x 5/8" FLARE	41002
3/4" IPS x 5/8" FLARE	41130
1" CTS x 5/8" FLARE	41150

### Permasert Three-Way Tees



SIZE	PART NUMBER
1/2" CTS	50199
1/2" IPS	50730100
3/4" IPS	50929
1" CTS	50292
1" IPS	50634
1 1/4" IPS	50327010

## Permasert Blind End Caps (Stop and Go – Both Ends Functional)



SIZE	PART NUMBER
1/2" CTS	50016
1/2" IPS	50716
3/4" IPS	50026
1" CTS	50045
1" IPS	51501
1 1/4" IPS	50033
2" IPS	50317

## Permasert Blind End Stubs (Dead-End Fitting – One End Functional)



SIZE	PART NUMBER
1/2" CTS	50015
3/4" IPS	50809
1" CTS	50048
1" IPS	50612
1 1/4" IPS	50024100
2" IPS	51770

## Permasert Three-Way Reducing Tees



SIZE	PART NUMBER
1/2" CTS x 1/2" CTS x 1" CTS	51335
3/4" IPS x 3/4" IPS x 1/2" CTS	50461
1" CTS x 1" CTS x 1/2" CTS	50451
1" IPS x 1" IPS x 1/2" CTS	50632
1" IPS x 1" IPS x 3/4" IPS	50635
1" IPS x 1" IPS x 1/2" IPS	50637
1 1/4" IPS x 1 1/4" IPS x 3/4" IPS	50992
1 1/4" IPS x 1" CTS x 1" CTS	51322
1 1/4" IPS x 1 1/4" IPS x 1" CTS	50328100
2" IPS x 2" IPS x 1" CTS	50348100
2" IPS x 2" IPS x 1 1/4" IPS (SDR11)	51285
2" IPS x 2" IPS x 1 1/4" IPS (SDR10)	51323100

## Permasert Elbows



SIZE	PART NUMBER
1/2" CTS	50294
1/2" IPS	50732100
3/4" IPS	51620
1" CTS	51333
1" IPS	50636
1 1/4" IPS	50325010
2" IPS	50315

*Our "All Flex" risers can bend around the tank making a clean looking installation with no joint underground.*

## Risers and Transitions

Note: No Cathodic Protection Required - Casing is Coated

### Anodeless Service Line Risers – Fusion Ends



PLASTIC INLET	PIPE OUTLET	VERT	HORIZ	PART NUMBER
1/2" CTS	3/4" MPT	18"	18"	75678
1/2" CTS	3/4" MPT	22"	18"	77202
1/2" CTS	3/4" MPT	30"	24"	75169
1/2" IPS	1/2" MPT	30"	25"	77221
1/2" IPS	3/4" MPT	30"	24"	79036
3/4" IPS	3/4" MPT	30"	24"	75251
1" CTS	3/4" MPT	30"	24"	77121
1" IPS	1" MPT	30"	24"	75751
1 1/4" IPS	1 1/4" MPT	30"	24"	75900
1 1/2" IPS	1 1/2" MPT	32"	32"	79799
2" IPS	2" MPT	30"	15"	79811

### Anodeless Service Line Risers – Permasert Mechanical Ends

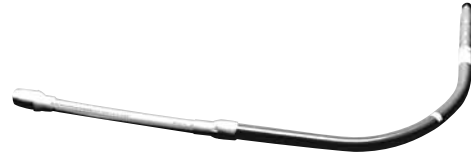

PLASTIC INLET	PIPE OUTLET	VERT	HORIZ	PART NUMBER
1/2" CTS	1/2" MPT	30"	24"	77253
1/2" CTS	3/4" MPT	22"	18"	77201
1/2" CTS	3/4" MPT	30"	24"	75192
3/4" IPS	3/4" MPT	30"	24"	79209
3/4" IPS	3/4" MPT	30"	26"	79206
1" CTS	3/4" MPT	30"	24"	77120
1" IPS	1" MPT	30"	24"	78442
1 1/4" IPS	1 1/4" MPT	30"	24"	75901
1 1/2" IPS	1 1/2" MPT	32"	32"	79784
2" IPS	2" MPT	30"	15"	75906

### Anodeless Service Line Risers – Permanent Mechanical Ends For Use with Underground Tanks

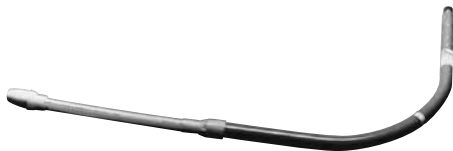

PLASTIC INLET	PIPE OUTLET	VERT	HORIZ	PART NUMBER
1/2" CTS	3/4" MPT	18"	18"	77195
1/2" CTS	1/2" MPT	18"	18"	77205

### Transition Fittings

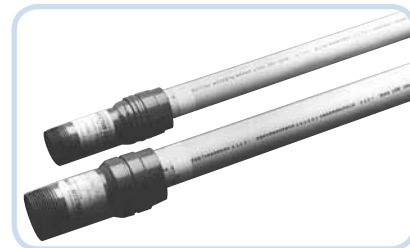

PLASTIC INLET	PIPE OUTLET	PART NUMBER
1/2" CTS	1/2" MPT	700004
1/2" CTS	3/4" MPT	700205
1/2" IPS	1/2" MPT	T-5000
1/2" IPS	1/2" MPT	70180*
3/4" IPS	3/4" MPT	700802
1" CTS	1" MPT	701407
1" IPS	1" MPT	701202
1 1/4" MPT	1 1/4" MPT	702205
1 1/2" IPS	1 1/2" MPT	702401
2" IPS	2" MPT	702602
3" IPS	3" MPT	702802

\*25" length



Whether, it's plastic pipe for the 1st stage or CSST for the 2nd stage, Tarantin has what you need. Call us today!

## PermaLock™ Mechanical Tapping Tees (PMTT)



### Accessory

Tapping Tee Tool Kit  
Part Number: 53913

PERMASERT OUTLET	MAIN SIZE	CUTTER SIZE	PART NUMBER
1/2" CTS	1 1/4" IPS	.55"	54201
1" CTS	1 1/4" IPS	.55"	54251
3/4" IPS	1 1/4" IPS	.55"	54290
1/2" CTS	2" IPS	.80"	55702
3/4" IPS	2" IPS	.80"	55901
1" CTS	2" IPS	.80"	55802
1" IPS	2" IPS	.80"	55951
1 1/4" IPS	2" IPS	.80"	55982
2" IPS	2" IPS	.80"	55990
1/2" CTS	4" IPS	.80"	55716
3/4" IPS	4" IPS	.80"	55902
1" CTS	4" IPS	.80"	55811
1" IPS	4" IPS	.80"	55953
1 1/4" IPS	4" IPS	.80"	55986
2" IPS	4" IPS	.80"	55992

## Anodeless Servi-Sert™ Field-Assembled Risers

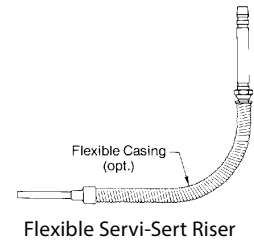

Flexible Servi-Sert Riser

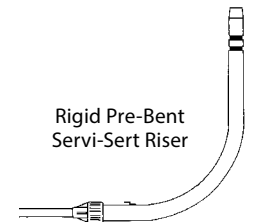

Rigid Pre-Bent Servi-Sert Riser

## Rigid (Pre-Bent) w/Liners (Centering Sleeves)\*



## Stub-Flex w/Liners (Centering Sleeves)\*



OUTLET	INLET	SDR/WALL	VERTICAL	HORIZONTAL	PART NUMBER
1/2" MPT	1/2" CTS	.090"	30"	24"	71350
3/4" MPT	1/2" CTS	.090"	30"	24"	71453
3/4" MPT	3/4" IPS	SDR 11	30"	24"	71304
1" MPT	1" CTS	.099"	30"	24"	71720
1" MPT	1" IPS	SDR 11	30"	24"	71730

OUTLET	INLET	SDR/WALL	NIPPLE	FLEX	PART NUMBER
1/2" MPT	1/2" CTS	.090"	15"	36"	71351
3/4" MPT	1/2" CTS	.090"	15"	36"	71463
3/4" MPT	3/4" IPS	SDR 11	17 1/2"	36"	71721
1" MPT	1" CTS	.099"	17 1/2"	36"	71600

## Anodeless Servisert Field Assembled "All Flex" Risers\* (w/Swivel Connector/Union)



OUTLET	INLET	SDR/WALL	OVERALL LENGTH	PART NUMBER
1/2" MPT	1/2" CTS	.090"	84"	71353
1/2" MPT	1/2" CTS	.090"	36"	71354
3/4" MPT	1/2" CTS	.090"	84"	71355
3/4" MPT	1/2" CTS	.090"	60"	71461
3/4" MPT	1/2" CTS	.090"	36"	71356
3/4" MPT	3/4" IPS	SDR 11	84"	71412
3/4" MPT	3/4" IPS	SDR 11	60"	71411
3/4" MPT	3/4" IPS	SDR 11	36"	71410
1" MPT	1" CTS	SDR 11	36"	71200

\* These risers are field assembled by inserting polyethylene tubing from the roll thereby allowing a continuous service line with no connections underground.



**Butt Fusion Fittings**

**Butt Fusion 90° Ell**

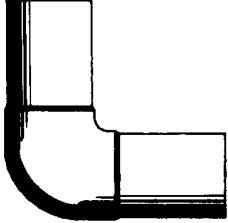

NOM. SIZE-IN.	PART NUMBER
2"	2-90L-B
3"	3-90L-B
4"	4-90L-B

**Butt Fusion 45° Ell**

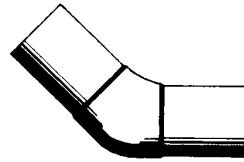

NOM. SIZE-IN.	PART NUMBER
2"	2-45L-B
3"	3-45L-B
6"	6-45L-B

**Butt Fusion Flange Adapters**

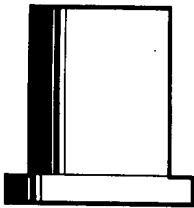

NOM. SIZE-IN.	PART NUMBER
2" IPS x 6" Long	2X6-F-B
3" IPS x 6" Long	3X6-F-B
4" IPS x 6" Long	4X6-F-B

**Butt Fusion Cap**

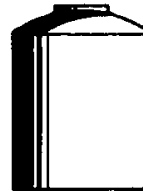

NOM. SIZE-IN.	PART NUMBER
2"	2-EC-B
3"	3-EC-B
4"	4-EC-B

**Butt Fusion Tee**

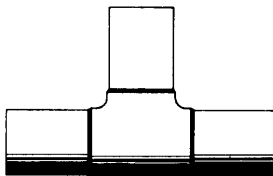

NOM. SIZE-IN.	PART NUMBER
1"	1-TEE-B
2"	2-TEE-B
3"	3-TEE-B
4"	4-TEE-B
6"	6-TEE-B

**Butt Fusion Branch Saddle**

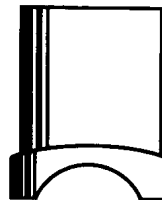

MAIN SIZE	OUTLET SIZE	PART NUMBER
2"	2" Butt Outlet	2X2-BS-B
3"	2" Butt Outlet	3X2-BS-B
4"	2" Butt Outlet	4X2-BS-B
3"	3" Butt Outlet	3X3-BS-B
4"	3" Butt Outlet	4X3-BS-B
4"	4" Butt Outlet	4X4-BS-B

**Butt Fusion Reducer**

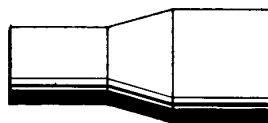

NOM. SIZE-IN.	PART NUMBER
2"X1" IPS	2X1-RC-B
2"X1 1/4"	2X1 1/4-RC-B
2"X1 1/2"	2X1 1/2-RC-B
3"X2"	3X2-RC-B
4"X2"	4X2-RC-B
4"X3"	4X3-RC-B

## Socket Fusion Fittings

### Fusion Couplings



NOM. SIZE-IN.	PART NUMBER
1/2 CTS	1/2-SC-CTS
1 CTS	1C-SC
1/2 IPS	1/2-SC
3/4 IPS	3/4-SC
1 IPS	1-SC
1 1/4 IPS	1 1/4-SC
2 IPS	2-SC
3 IPS	3-SC
4 IPS	4-SC

### Fusion Reducing Tee

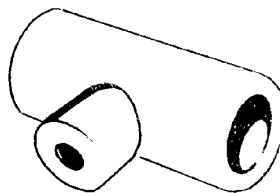

NOM. SIZE-IN.	PART NUMBER
1 IPS x 1 IPS x 1/2 IPS	1x1x1/2RT
1 IPS x 1 IPS x 1/2 CTS	1x1x1/2CRTCTS

### Fusion Tee

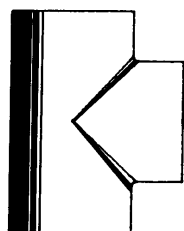

NOM. SIZE-IN.	PART NUMBER
1/2 CTS	1/2C-TEE
1 CTS	1C-TEE
1/2 IPS	1/2-TEE
3/4 IPS	3/4-TEE
1 IPS	1-TEE
1 1/4 IPS	1 1/4-TEE
2 IPS	2-TEE
3 IPS	3-TEE
4 IPS	4-TEE

### Fusion Branch Saddle

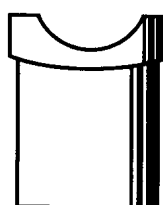

NOM. SIZE-IN.	PART NUMBER
2 IPS x 1 1/4 IPS	2x1 1/4BS
3 IPS x 1 1/4 IPS	3x1 1/4BS
4 IPS x 1 1/4 IPS	4x1 1/4 BS
2 IPS x 2 IPS	2x2BS
3 IPS c 2 IPS	3x2BS
4 IPS x 2 IPS	4x2BS

### 90° Fusion Ell

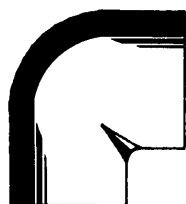

NOM. SIZE-IN.	PART NUMBER
1/2 CTS	1/2C-90L
1 CTS	1C-90L
1/2 IPS	1/2-90L
3/4 IPS	3/4-90L
1 IPS	1-90L
1 1/4 IPS	1 1/4-90L
2 IPS	2-90L
3 IPS	3-90L
4 IPS	4-90L

### Fusion Reducing Coupling

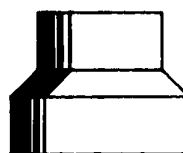

NOM. SIZE-IN.	PART NUMBER
1/2 IPS x 1/2 CTS	1/2x1/2CRC
3/4 IPS x 1/2 IPS	3/4x1/2RC
3/4 IPS x 1/2 CTS	3/4x1/2CRC
1 CTS x 1/2 CTS	1Cx1/2C-RC
1 IPS x 1/2 CTS	1x1/2C-RC
1 IPS x 1/2 IPS	1x1/2RC
1 IPS x 1 CTS	1x1CRC
1 IPS x 3/4 IPS	1x3/4RC
1 1/4 IPS x 1 IPS	1 1/4x1RC
1 1/4 IPS x 1 CTS	1 1/4x1C-RC
2 IPS x 1 IPS	2x1RC
2 IPS x 1 1/4 IPS	2x1 1/4RC
3 IPS x 2 IPS	3x2RC
4 IPS x 2 IPS	4x2RC
4 IPS x 3 IPS	4x3RC

### Fusion Cap



NOM. SIZE-IN.	PART NUMBER
1/2 CTS	1/2C-EC
1 CTS	1C-EC
1/2 IPS	1/2-EC
3/4 IPS	3/4-EC
1 IPS	1-EC
1 CTS	1C-EC
1 1/4 IPS	1 1/4-EC
1 3/4 CTS	1 3/4C-EC
2 IPS	2-EC
3 IPS	3-EC
4 IPS	4-EC

**Electric Fusion Tools**

**Our Most Popular Model 2 Heating Tool Part No. MH3000-102**

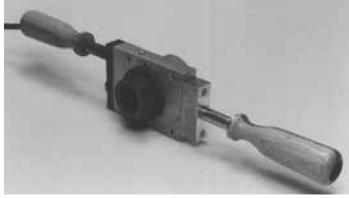

Socket fusion  
1/2" CTS-2" IPS  
Butt fusion  
1/2" IPS- 3" IPS  
Sidewall fusion 1 1/4"-8"  
800 Watts, 8 Amps,  
115VAC only.

**Model 4SW Heating Tool Part No. 556-0022**



Socket fusion  
1/2" IPS-2" IPS  
Butt fusion  
1/2" IPS-4" IPS  
Sidewall fusion 1 1/2"-8"  
1600 Watts, 14 AMPS,  
115VAC

**Fusion Tools Gas Fired**



**2" Hot Head  
Part No. HH3000**

Gas fired heating  
head.  
Socket fusion  
1/2" CTS-2" IPS  
Tank not included.



**Model 4 Gas Fired Combination Head  
Part No. 566-0023**

Socket fusion  
1/2" IPS-4" IPS  
Butt fusion  
1/2" IPS-4" IPS  
Tank not included.

**Accessories**

**Extended Handle**

Fits Model 2 and Model 45W  
Part No. HM3000-102

**Nozzle Regulator**

Fits Gas Fired Heaters  
Part No. MM0120

**Fusion Accessories**

**Socket Fusion Faces**



SIZE-IN.	PART NUMBER
1/2 CTS	SP2620
1/2 IPS	SP2500
3/4 IPS	SP2750
1 IPS	SP2010
1 CTS	SP2110
1 1/4 IPS	SP2120
2" IPS	SP2020
3" IPS	SP2030

**Butt Fusion Faces**

Call for proper sizing

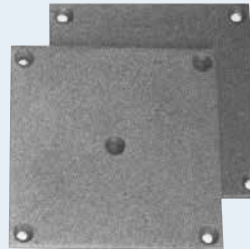

**Combination 3" and 4" Depth Gauge**



SIZE-IN.	PART NUMBER
1/2 CTS	DG0620
1/2 IPS	DG1500
3/4 IPS	DG1750
1 IPS	DG1010
1 CTS	DG0110
1 1/4 IPS	DG1120
2" IPS	DG1020
3&4"	DG3040

**Cold Ring - A**



SIZE-IN.	PART NUMBER
1/2 CTS	CR0620
1/2 IPS	CR0500
3/4 IPS	CR0750
1 IPS	CR0010
1 CTS	CR0110
1 1/4 IPS	CR0120
2 IPS	CR0020
3 IPS	CR0030
4 IPS	CR0040

**Combo Depth Gauge Chamfering Tool**

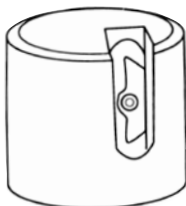

PART NUMBER	DESCRIPTION
SW08709	3/4" IPS
SW08707	1" IPS
SW08705	1 1/4" IPS
SW08701	2" IPS



**Heater Muff  
Part No. HM 3000**

Fits all heater tools.  
Protects heater tool,  
maintains temperature.

## Permasert PSV™ Polyethylene Shut-off Valves – Permasert Outlet Ends

SIZE-IN.	PART NUMBER
1/2" CTS	45051-P
3/4" IPS	45110-P
1" CTS	45071-P
1" IPS	45201-P
1 1/4" IPS	45170100
2" IPS	45600



## Tee Handles



PART NUMBER	DESCRIPTION
SRVW15	Tee Handle Wrench for Shut-Off Valve 15" long
SRVW24	Tee Handle Wrench for Shut-Off 24" long
SRVW60	Tee Handle Wrench for Shut-Off 60" long

## Socket Fusion Shut-Off Valves Meets P.E. 2406 Spec



PART NUMBER	DESCRIPTION	CURB BOX
UGB1/2	1/2" U.G. Valve	CBA
U075IPS	3/4" U.G. Valve	CBA
U100IPS	1" U.G. Valve	CBA
U125IPS	1 1/4" U.G. Valve	CBA
UGV2	2" U.G. Valve	CBG
UGV3	3" U.G. Valve	CBG

Note: Butt Fusion Valves and larger sizes available—call.

## Metallic and Non-Metallic Locator Tape

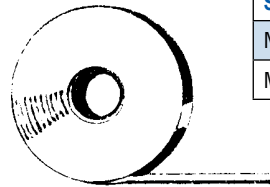

SIZE	PART NUMBER
Non-Metallic Locator Tape	715-CGT-31
Metallic Locator Tape	715-NCGT21

**CAUTION GAS LINE BURIED BELOW**

Metallic Tape buried 6" below grade allows detection with metal detector up to 12"

Also available - No. 12 Tracer Wire

## Box and Valve Support



PART NUMBER	DESCRIPTION
VCS-5	Fits Valves 1/2" - 1/4"
VC9	Fits 2" Valves
VV8	Fits 3" Valves

## Curb Boxes



PART NUMBER	DESCRIPTION
GIF2-2A	Cast Iron Collar, adjustable: 18-5/8" to 24", Fits 1/2"-1 1/4" valve

## PERMASERT 2" Tool Kit

When installing 2" Permasert couplings, you'll find our Assembly Tool is better than a second pair of hands! The kit contains everything needed to get the job done: 2" Chamfering Tool, Marking Pencil, and the 2" Perma-Snip Cutting Tool.

Part Number: 51050-K



**Tools and Accessories**

**Brackets**

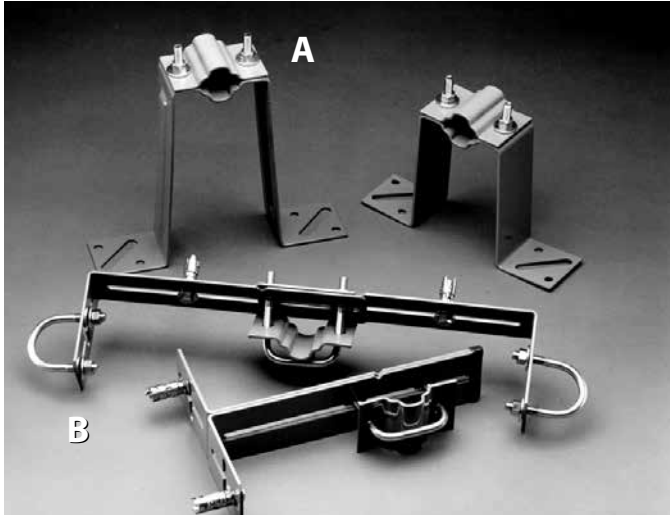

**A Wall Brackets**

SIZE	NOMINAL BUILDING OFFSET	PART NUMBER
3/4" - 2" IPS Casing	4"	74506
3/4" - 2" IPS Casing	9"	74491
3/4" - 2" IPS Casing	6"	74500

**B Universal Mount Riser Bracket Kit**

Fits sizes from 3/4" IPS casing through 2" IPS casing for foundation mount or remote meter installation.

Part No. 74440

**Accessories**

Description	Part Number
Wall Mounting Hardware	
Includes Lead Anchors, Washers & Bolts	09800
5 Ft. Support Post	31733

**Squeeze-Off Tool**



Precision stops prevent over squeezing and damaging. Designed for 1/2" IPS-2" IPS.  
Part Number: 557-0006

**Small Cutter**

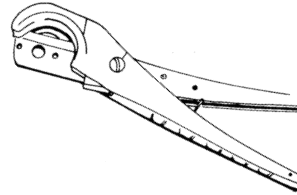

Snips 1/8" through 1 1/4" OD Material

Part Number: 55190

Replacement Blades 55200

**Medium Cutter**



Snips 1/8" through 1 1/2" OD Material

Part Number: 55290

Replacement Blades 55300

**Large Cutter**



Snips 1/8" through 2 3/8" OD Material

Part Number: 55291

Replacement Blades 57300

**Chamfering Tools**



SIZE	PART NUMBER
1/2" CTS x 1" CTS	51004
1/2" CTS x 3/4" IPS	51016
1/2" IPS x 3/4" IPS	51006
3/4" IPS x 1" IPS	51008
1 1/4" IPS	51028
1 1/2" IPS	51041
2" IPS	51040
3" IPS	CT0030

Replacement Blade for all tools 1/2" CTS - 1 1/4" IPS  
Replacement Blade for 2"

51071  
52427

## TracPipe Gas Piping – CSST

**Counterstrike** The First Flexible Gas Piping Available to Provide Enhanced Protection From Lightning. CounterStrike is a TracPipe patent-pending CSST innovation that is engineered to significantly decrease the potential for lightning induced damage to fuel gas piping systems.



FGP-CS-500-250

PART NUMBER	SIZE	REEL LENGTH
FGP-CS-375	3/8"	250 ft
FGP-CS-500	1/2"	100 ft / 250 ft
FGP-CS-750	3/4"	100 ft / 250 ft
FGP-CS-1000	1"	180 ft
FGP-CS-125	1 1/4"	150 ft
FGP-CS-150	1 1/2"	150 ft
FGP-CS-200	2"	150 ft

Counterstrike is sized exactly the same as conventional TracPipe and uses the same AutoFlare fittings.

FGP-RST-500-750



### AutoFlare Fittings – Reducing

PART NUMBER	TUBE SIZE IN.	PKG QTY
FGP-RST-500-750	1/2"-3/4"	24
FGP-RST-750-500	3/4"-1/2"	16
FGP-RST-1000-750	1"-3/4"	16

FGP-FST-375



### AutoFlare Fittings – Straight

PART NUMBER	TUBE SIZE IN.	PKG QTY
FGP-SFST-375	3/8"	24
FGP-SFST-500	1/2"	24
FGP-SFST-750	3/4"	16
FGP-SFST-1000	1"	16
FGP-FST-1250	1 1/4"	6
FGP-FST-2000	2"	4

FGP-FSTF-500



### Auto Flare Fittings – Female Straight

PART NUMBER	TUBE SIZE IN.	PKG QTY
FGP-FSTF-375	3/8"	24
FGP-FSTF-500	1/2"	24
FGP-FSTF-750	3/4"	16
FGP-FSTF-1000	1"	16

FGP-BFF-500



### Flange Fitting

PART NUMBER	TUBE SIZE IN.	PKG QTY
FGP-BFF-375	3/8"	12
FGP-BFF-500	1/2"	12
FGP-BFF-750	3/4"	8
FGP-BFF-1000	1"	8
FGP-BFF-1250	1 1/4"	4

FGP-TF1000-T500



### Reducing Tees

PART NUMBER	SIZE IN.	PKG QTY
FGP-TF1000-T500	1 X 1 X 1/2	10
FGP-RT-1001	1 X 3/4 X 1/2	10
FGP-RT-752	3/4 X 1/2 X 1/2	12
FGP-TF750-T500	3/4 X 3/4 X 1/2	12
FGP-RT-1002	1 X 3/4 X 3/4	10

FGP-TF500-T500



### Tee – TracPipe by TracPipe Outlet

PART NUMBER	TUBE SIZE IN.	PKG QTY
FGP-TF500-T500	1/2"	14
FGP-TF750-T750	3/4"	12
FGP-TF1000-T1000	1"	10

### Tee – TracPipe by Pipe Outlet

PART NUMBER	TUBE SIZE IN.	PKG QTY
FGP-T500-500	1/2 X 1/2	14
FGP-T750-500	3/4 X 1/2	12



### Shutoff Valves

PART NUMBER	DESCRIPTION	SIZE IN.
FGP-WBV-500	5 PSI Ball Valve	1/2"
FGP-WBV-750	5 PSI Ball Valve	3/4"



### Manifolds

PART NUMBER	DESCRIPTION	SIZE IN.
FGP-LC	Load Center with Bracket	
FGP-MB2	Mainfold Bracket	
FGP-MI-ST-500	Stackable Manifold 2 Ports	1/2" F x 1/2"
FGP-MI-ST-750	Stackable Manifold 2 Ports	3/4" F x 1/2"
FGP-MI-PC	Coated Manifold 4 Ports	3/4" x 1/2" x 1/2"



### Cutting Tools

PART NUMBER	DESCRIPTION	SIZE IN.
FGP-TC-15	Small Cutter # 15	3/8"-1"
FGP-TC-151	Large Cutter # 151	3/8"-1 1/4"
FGP-TC-152	XL Cutter # 152	1 1/4"-2"
FGP-E-5272	Cutter Wheel for XL	1 1/4"-2"



### Protection Devices

PART NUMBER	DESCRIPTION	SIZE IN.	PKG QTY
FGP-SP-025	Quarter Striker Plate	3" x 2"	1
FGP-SP-050	Half Striker Plate	3" x 7"	1
FGP-SP-100	Full Striker Plate	3" x 12"	1
FGP-SP-617	Flat Striker Plate	6 1/2" x 17"	1
FGP-FPY-375-50	Conduit	3/4"	50ft
FGP-FPY-500-50	Conduit	1"	50ft
FGP-FPY-750-25	Conduit	1 1/4"	25ft
FGP-FPY-1250-25	Conduit	2"	25ft
FGP-FPY-375CT	Conduit	3/4"	25ft
FGP-FPY-500CT	Conduit	1"	50 pcs
FGP-FPY-750CT	Conduit	1 1/4"	50 pcs



### Elbow Flange Fitting 90 degree

PART NUMBER	TUBE SIZE IN.	PKG QTY
FGP-ELLB-375	3/8"	8
FGP-ELLB-500	1/2"	8

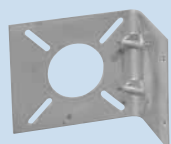

### Flange Bracket

Part Number: FGP-TERM-BRAC

## TracPipe PS-II

TracPipe PS-II is a pre-sleeved gas installation system for underground, rooftop, or exterior wall applications that is more cost effective and easier to install vs. the original TracPipe PS System.



FGP-UGP-500-250

PART NUMBER	SIZE	REEL LENGTH
FGP-UGP-375	3/8"	250 ft
FGP-UGP-500	1/2"	250 ft
FGP-UGP-750	3/4"	250 ft
FGP-UGP-100	1"	250 ft
FGP-UGP-125	1 1/4"	150 ft
FGP-UGP-150	1 1/2"	150 ft
FGP-UGP-200	2"	150 ft

## Male Adapters



FGP-UGF-500

PART NUMBER	SIZE	PKG SIZE
FGP-UGF-375	3/8" NPT Male	25
FGP-UGF-500	1/2" NPT Male	20
FGP-UGF-750	3/4" NPT Male	16
FGP-UGF-1000	1" NPT Male	9
FGP-UGF-1250	1 1/4" NPT Male	9
FGP-UGF-1500	1 1/2" NPT Male	9
FGP-UGF-2000	2" NPT Male	5

## Couplings

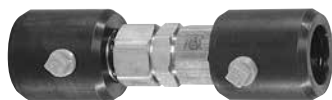

FGP-UGC-500

PART NUMBER	SIZE	PKG SIZE
FGP-UGC-375	3/8"	25
FGP-UGC-500	1/2"	20
FGP-UGC-750	3/4"	16
FGP-UGC-1000	1"	9
FGP-UGC-1250	1 1/4"	9
FGP-UGC-1500	1 1/2"	8
FGP-UGC-2000	2"	5

## GasBreaker



FGP-GB300-075

PART NUMBER	DESCRIPTION	SIZE	PKG QTY
FGP-GB090-075	70 CFH Appliance	3/4'	1
FGP-GB150-075	100 CFH Appliance	3/4"	1
FGP-GB300-075	175 CFH Appliance	3/4"	1
FGP-GB300-100	175 CFH Appliance	1"	1
FGP-GB400-100	250 CFH Appliance	1"	1
FGP-GB600-100	300 CFH Appliance	1"	1



**Sizing Table for Low Pressure Propane (Standard)**

**Maximum Capacity of Omegaflex Tracpipe™  
in Thousands of BTU per Hour Propane Gas**

**Gas Pressure: 11 in. W.C. Pressure Drop: .05 in W.C. (based on a 1.52 Specific Gravity Gas)**

SIZE	(EHD)	5	10	15	20	25	30	40	50	60	70	80	90	100	150	200	250	300
3/8"	15	99	69	55	49	42	39	33	30	26	25	23	22	20	15	14	12	11
1/2"	19	211	150	121	106	94	87	74	66	60	57	52	50	47	36	33	30	26
3/4"	25	456	325	267	232	209	191	166	149	136	126	118	112	106	87	76	68	62
1"	31	863	605	490	425	379	344	297	265	241	222	208	197	186	143	129	117	107
1-1/4"	37	1753	1247	1021	887	795	727	631	566	517	479	449	424	402	329	286	256	234
1-1/2"	46	2830	1993	1623	1404	1254	1143	988	884	805	745	696	656	621	506	438	390	357
2"	62	6547	4638	3791	3285	2940	2684	2327	2082	1902	1761	1647	1554	1475	1205	1045	934	854

EHD (Effective Hydraulic Diameter) A relative measure of Flow Capacity; This number is used to compare individual sizes between different manufactures. The higher the EHD number the greater flow capacity of the piping.

**Sizing Table for Propane at 2psi**

**Maximum Capacity of Omegaflex Tracpipe™  
in Thousands of BTU per Hour Propane Gas**

**Gas Pressure: 2psi Pressure Drop: 1 psi (based on a 1.52 Specific Gravity Gas)**

SIZE	(EHD)	10	25	30	40	50	75	80	100	150	200	250	300	400	500
3/8"	15	558	347	316	271	243	196	189	169	137	118	105	96	82	72
1/2"	19	1106	701	640	554	496	406	393	350	287	248	222	203	175	158
3/4"	25	2282	1464	1340	1165	1046	859	833	748	614	534	479	439	381	342
1"	31	4720	2954	2692	2323	2072	1685	1629	1454	1182	1019	910	829	716	638
1-1/4"	37	8963	5714	5224	4537	4066	3332	3228	2893	2370	2058	1845	1687	1464	1312
1-1/2"	46	15174	9549	8708	7529	6726	5480	5303	4738	3860	3337	2981	2719	2351	2101
2"	62	34203	21680	19801	17159	15357	12551	12154	10877	8890	7705	6895	6296	5457	4883

Table does not include effect of pressure drop across the line regulator. If regulator loss exceeds 3/4 PSI (based on 8 inch outlet pressure) Do not use this chart. Pressure drops across a regulator vary with flow rate. FGP-REG-3P has a 3/4 PSI drop at a flow of 161 cubic feet per hour. CAUTION: capacities shown in table may exceed maximum capacity for a selected regulator.

EHD (Effective Hydraulic Diameter) A relative measure of Flow Capacity; This number is used to compare individual sizes between different manufactures. The higher the EHD number the greater flow capacity of the piping

## PRESSURE FACTORS

### POSITIVE DISPLACEMENT METER

Always caution Customers to open Inlet & Outlet valves extremely slowly when using elevated pressure.

POUNDS	FACTOR	POUNDS	FACTOR
0	0.998	41	3.76
1	1.05	42	3.83
2	1.11	43	3.9
3	1.18	44	3.97
4	1.25	45	4.03
5	1.32	46	4.1
6	1.39	47	4.17
7	1.45	48	4.24
8	1.52	49	4.3
9	1.59	50	4.37
10	1.66	51	4.44
11	1.72	52	4.51
12	1.79	53	4.58
13	1.86	54	4.64
14	1.93	55	4.71
15	2	56	4.78
16	2.06	57	4.85
17	2.13	58	4.92
18	2.2	59	4.98
19	2.27	60	5.05
20	2.34	61	5.12
21	2.4	62	5.19
22	2.47	63	5.26
23	2.54	64	5.32
24	2.61	65	5.39
25	2.68	66	5.46
26	2.74	67	5.53
27	2.81	68	5.59
28	2.88	69	5.66
29	2.95	70	5.73
30	3.01	71	5.8
31	3.08	72	5.87
32	3.15	73	5.93
33	3.22	74	6
34	3.29	75	6.07
35	3.35	76	6.14
36	3.42	77	6.21
37	3.49	78	6.27
38	3.56	79	6.34
39	3.63	80	6.41
40	3.69		

To convert to gallons multiply cubic feet by the lbs factor, and then divide the result by 36.28

## ANODE TESTING PROCEDURE

### Measuring Tank-to-Soil Cathodic Protection Potentials On Propane Tanks

Equipment: Digital Voltmeter, Test leads, Reference Electrode (Copper/Copper Sulfate half cell)

#### STEP 1:

Using a digital voltmeter select the 2 volt DC scale, Contact red test lead to the tank test point or an uncoated metallic area of the tank, preferably to the uncoated fill pipe. (Do not connect to shroud.) Note: If using a two-input analog meter, black lead will be connected to tank.

#### STEP 2:

Contact the black test lead from the meter to a charged reference electrode. (see charging electrode below) Note: If using a two-input analog meter, contact red lead to reference electrode.

#### STEP 3:

Remove protective cap from porous plug at bottom end of electrode. Place porous plug end into native earth directly above buried tank. Moisten soil with water or dig plug into soil if difficulty is encountered obtaining a reading.

#### STEP 4:

Observe meter reading and record. Reading should be at least -.850v or above. For other applicable criteria refer to NACE Standards RP0285-95 and RP0169-96, Corrosion Control of Underground Storage Tank Systems and Control of External Corrosion on Underground or Submerged Metallic Piping Systems.

Note: It is recognized through NACE that all readings be recorded as negative.

### Charging Reference Electrode:

#### STEP 1:

Unscrew and remove porous plug end of new reference electrode. Add deionized or distilled water to the copper sulfate crystals, filling electrode completely. The solution will turn blue in color and there should always be excess crystals at the bottom of the tube. DO NOT USE TAP WATER.

#### STEP 2:

Replace porous plug end of electrode and place in an upright position so that the porous plug end is facing in the down position and let stand for 15 minutes before use. This will allow the porous plug to become completely saturated before use. Caution: Do not allow electrode to contact oil, road salts, or other substances that may contaminate the solution by absorption through porous plug.

Do not allow electrode to freeze.

### Male NPT by Hose Barb



PART NUMBER	HOSE ID	THREAD SIZE
HC-4231	1/4"	1/8"
HC-4232	1/4"	1/4"
HC-4233	1/4"	3/8"
HC-4252	3/8"	1/4"
HC-4253	3/8"	3/8"
BG30 FE	3/8"	1/2"

### Female NPT by Hose Barb



PART NUMBER	HOSE ID	THREAD SIZE
HC-4631	1/4"	1/8"
HC-5632	1/4"	1/4"
BG-32EC	1/4"	3/8"
BG-32CE	3/8"	1/4"
BG-32EE	3/8"	3/8"
HC-4654	3/8"	1/2"

### Male Pipe X Hose Barb High Pressure Fittings

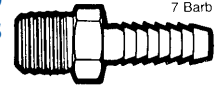

PART NUMBER	DESCRIPTION
HC-5232	1/4" Male Pipe Thread X 1/4" Hose Barb
HC-5233	3/8" Male Pipe Thread X 1/4" Hose Barb

### Male Flare by Hose Barb



PART NUMBER	HOSE ID	THREAD SIZE
HC-4835	1/4"	3/8" OD
HC-4855	3/8"	3/8" OD
HC-4857	3/8"	1/2" OD

### Female Flare Swivel by Hose Barb



PART NUMBER	HOSE ID	THREAD SIZE
HC-4335	1/4"	3/8" OD
HC-4355	3/8"	3/8" OD
HC-4357	3/8"	1/2" OD

### Female Flare Swivel X Hose Bars High Pressure Fittings

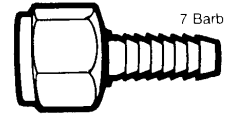

PART NUMBER	DESCRIPTION
HC-5335	3/8" Female Flare Adapter X 1/4" ID Hose Barb
HC-5333	1/4" Female Flare Adapter X 1/4" ID Hose Barb

### POL by Hose Barb

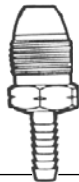

PART NUMBER	HOSE ID	THREAD SIZE
HC-5930	1/4"	POL, Full Flow
G-1683	1/4"	POL/Excess Flow 7/8 Hex
G-1684	1/4"	POL/Excess Flow 1 1/8 Hex
G-1656	1/4"	POL Soft Nose W/Handwheel
G-1655	1/4"	POL/Handwheel Excess Flow

### 9/16" - 18LH Female by Hose Barb

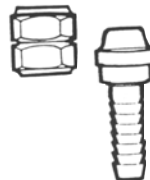

PART NUMBER	HOSE ID	THREAD SIZE
G-201	Nut	9/16-18LH
G-622	Stem	1/4 Hose
G-624	Stem	3/8 Hose

### Male Swivel Adapter

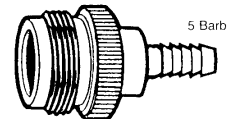

PART NUMBER	DESCRIPTION
G-496	Male 1"-20 Swivel X 1/4" Hose Barb

### 9/16" - 18LH by Hose Barb



PART NUMBER	HOSE ID	THREAD SIZE
A 61	1/4"	Male 9/16-18LH

### 1/4" Male Inverted Flare by Hose Barb



PART NUMBER	HOSE ID	THREAD SIZE
HC-5133	1/4"	1/4" Male Inv. Flare

### Male Flare X Hose Barb High Pressure Fittings

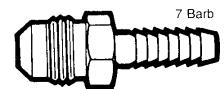

PART NUMBER	DESCRIPTION
HC-5835	3/8" Male Flare Swivel X 1/4" ID Hose Barb



Don't see a part you are looking for? Call us! If we don't have it, we'll try to find it for you.

## 916" - 18LH Hose Connector



G-203

PART NUMBER	THREAD SIZE
G-203	9/16" - 18LH X 9/16" - 18LH
G-212	1/4" MPT X 9/16" - 18LH
B51	3/8" MPT X 9/16" - 18LH

## Brass Hose Ferrules



PART NUMBER	INSIDE DIAMETER	COMMON USAGE
7326	0.593	1/4" Single Braid
7327	0.625	1/4" Single Braid
7328	0.656	1/4" Double Braid
7329	0.687	1/4" Double Braid
7332	0.781	3/8" Single Braid
7333	0.812	3/8" Double Braid

## Hose Ferrule Crimping Tools

### Bench Type



CR-100

PART NUMBER	DESCRIPTION
CR-100	Crimps Ferrules on 3/16", 1/4", 5/16" & 3/8" ID Hose

### Vice Grip Type



KT-28

PART NUMBER	DESCRIPTION
KT-28	Crimps 3/16" & 1/4" Hose
KT-29	Crimps 5/8" - 11/16"

## Soft Nose Handwheel POL X Hose Barb High Pressure Fittings

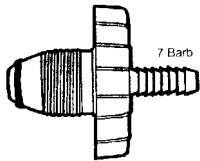

7 Barb

PART NUMBER	DESCRIPTION
G-1656	Soft Nose with Handwheel X 1/4" ID Hose Barb
G-1655	Excess Flow Soft Nose POL With Handwheel X 1/4" Hose Barb

## Female Swivel Adapter

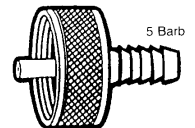

5 Barb

PART NUMBER	DESCRIPTION
G-484	Female 1" 20 Swivel X 1/4" Hose Barb

## QCC Fittings



PART NUMBER	DESCRIPTION	COLOR
G-1851-A02	Type 1 QCC x 1/4 MPT	Black
G-1851-A03	Type 1 QCC x 1/4 MPT	Green
G-1851-C02	Type 1 QCC x 1/4 HB	Black
G-1851-C03	Type 1 QCC x 1/4 HB	Green

## Dayco L.P. Gas Hose



Service: A flexible, heavy duty high pressure hose for transfer of liquid or vapor propane or butane, in heater, torch, filling, delivery and unloading applications.

PART NUMBER	I.D. (IN.)	BRAID	O.D. (IN.)	APPROX. WT. PER 100 FT.	MAX RECOM. WP (PSI)
LPH-1/4INDB	1/4	2	5/8	16	350
LPH-3/8INDB	3/8	2	3/4	22	350
LPH-1/2IN	1/2	2	15/16	31	350
LPH-3/4IN	3/4	2	1 1/4	49	350
LPH-1IN	1	2	1 1/2	61	350
LPH-1-1/4IN	1 1/4	2	1 7/8	100	350
LPH-1-1/2 IN	1 1/2	3	2 5/32	110	350
LPH-2IN	2	3	2 3/4	157	350

## L.P. Gas Hose with Crimped Hose Couplings



1/2" TO 2" MPT

These hoses have hydraulically pressed-on ends, and the entire assembly is tested to meet current DOT standards with certificate.

**Crimped and Tested**

PART NUMBER	HOSE SIZE	LENGTH
LPH-3/4X100P	3/4"	100 FT
LPH-3/4X150P-T	3/4"	150 FT
LPH-1INX125P-T	1"	125 FT
LPH-1INX150P-T	1"	150 FT
LPH-1INX175P-T	1"	175 FT
I16C1500MP16M16	1"	125 FT
I16C1800MP16M16	1"	150 FT

## L.P. Gas Hose Stainless Steel Braid

Stainless steel wire braid reinforced hose with neoprene cover provides extra protection and hose life. For plant, transport, bobtail, flexible connectors.



PART NUMBER	I.D. (IN.)	BRAID	O.D. (IN.)	APPROX. WT. PER 100 FT.	MAX RECOM. WP (PSI)
LPH-1INLT	1	1	1 1/2	75	350
LPH-1-1/4INSS	1 1/4	1	1 3/4	92	350
LPH-1-1/2IN	1 1/2	1	2	113	350
LPH-2INSS	2	2	2 43/64	187	350

ANY LENGTH AVAILABLE WITH CRIMPED COUPLING EXCEPT 2". MINIMUM 12".

## Stainless Steel Braid Hose with Cloth Cover for Motor Fuel



PART NUMBER	I.D. (IN.)	BRAID	O.D. (IN.)	APPROX. WT. PER 100 FT.	MIN. BEND RADIUS (IN.)	MAX RECOM. WP (PSI)
LPH-5/16SS	5/16	1	43/64	20	2	350

## Clamp Hose Couplings



M3162  
Standard  
Outlet



M3162  
Swivel Nut Outlet

Two-bolt couplings with either standard outlet (M.NPT) or swivel nut outlet on the larger sizes that saves weight and space on large hoses. Suitable for NH3 or LP-Gas service.

COUPLING STYLE	SIZE	HOSE I.D.	APPROX. HOSE O.D.	TYPE NUMBER
Clamp Type, Standard Outlet	1/2" M.NPT	1/2"	15/16"	M3162-08
Clamp Type, Standard Outlet	3/4" M.NPT	3/4"	1 1/4"	M3162-12
Clamp Type, Standard Outlet	1" M.NPT	1"	1 1/2"	M3162-16
Clamp Type, Standard Outlet	1 1/4" M.NPT	1 1/4"	2"	M3162-20
Clamp Type, Standard Outlet	1 1/2" M.NPT	1 1/2"	2 1/4"	M3162-24
Clamp Type, Standard Outlet	2" M.NPT	2"	2 3/4"	M3162-32
Clamp Type, Standard Outlet	3" M.NPT	3"	3 3/4"	M3162-48
Clamp Type, Swivel Nut Outlet	3 1/4" F. ACME	2"	2 3/4"	M3162-32S
Clamp Type, Swivel Nut Outlet	3 1/4" F. ACME	2"	2 3/4"	M3162-32B*
Clamp Type, Swivel Nut Outlet	4 1/4" F. ACME	3"	3 3/4"	M3162-48S

\* Brass nut, steel nipple. All other steel.

## Swivel Hose Adapter Unions

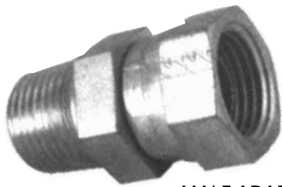

MALE ADAPTER



FEMALE ADAPTER

MALE ADAPTER	FEMALE ADAPTER	SIZE
8/8/45	0207-8-8	1/2"
12/12/45	0207-12-12	3/4"
2045-16-16	0207-16-16	1"
2045-20-20	0207-20-20	1 1/4"
2045-24-24	0207-24-24	1 1/2"
2045-32-32	0207-32-32	2"

## Coupling for Stainless Braid Motor Fuel Hose



SS-FFL



SS-MPT



SSAFL-45



SSAFL-90

PART NUMBER	HOSE ID	THREAD SIZE
SS-MPT	5/16"	1/4" MPT
SS-FFL	5/16"	3/8" F. FLARE
SS-MFL	5/16"	3/8" M. FLARE
SSAFL-45	5/16"	3/8" F. FLARE 45°
SSAFL-90	5/16"	3/8" F. FLARE 90°

## Stainless Steel Gas Appliance Connectors

Dormont residential connectors are durable, flexible, and easy to install...even in tight places. Designed with built-in safety features, Super-Safe connectors help prevent dangerous gas leaks and provide for a long and trouble-free service life. CSA design certified.



**5/8" O.D. (1/2" I.D.)  
Range Connectors  
1/2" FPT x 1/2" MPT**

PART NUMBER	LENGTH
1650NX12	12"
1650NX18	18"
1650NX24*	24"
1650NX30	30"
1650NX36*	36"
1650NX48	48"
1650NX60	60"

\* For 3/4" ends add - 3/4

**1/2" O.D. (3/8" I.D.)  
Dryer Connectors  
1/2" FPT x 1/2" MPT**

PART NUMBER	LENGTH
1637NX12	12"
1637NX18	18"
1637NX24	24"
1637NX30	30"
1637NX36	36"
1637NX48	48"
1637NX60	60"
1637NX72	72"

**3/8" O.D. (1/4" I.D.)  
Heater Connectors  
3/8" FPT x 3/8" MPT**

PART NUMBER	LENGTH
1625NX12	12"
1625NX18	18"
1625NX24	24"
1625NX30	30"
1625NX36	36"
1625NX48	48"



1650NX12



1637NX12



1625NX12

## Black Epoxy Coated Stainless Steel Gas Connectors

**3/8" MIP x 1/2" FIP**

PART NUMBER	LENGTH
20A-2132-18**	18"
20A-2135-12*	12"
20A-2135-18*	18"
20A-2135-24*	24"
* With ball valve	-

\*\* Not shown ball valve not included

These Dormont connectors are specifically designed for high temperature applications such as gas logs, fireplace inserts and free standing fireplaces.



## Gas Connectors for Commercial Equipment

Dormont exclusive design is comprised of a corrugated stainless steel hose encased in a stainless steel braid and covered in a thick PVC coating. For moveable applications, a quick disconnect coupling is attached enabling commercial cooking equipment to be easily and safely disconnected for cleaning and service. A restraining device is required for moveable applications.

### Dormont Gas Connector with Quick Disconnect Coupling



#### Restraining Device and Hardware



PART NUMBER	SIZE
RDC-24	For 24" Connector
RDC-36	For 36" Connector
RDC-48	For 48" Connector
RDC-60	For 60" & 72" Connector

#### Quick Disconnect Coupling



PART NUMBER	SIZE
B-37	3/8" FPT
A-50	1/2" FPT
A-75	3/4" FPT
A-100	1" FPT
A-125	1-1/4" FPT

PART NUMBER	SIZE	LENGTH
1650BPQX24	1/2"	24"
1650BPQX36	1/2"	36"
1650BPQX48	1/2"	48"
1650BPQX60	1/2"	60"
1650BPQX72	1/2"	72"
1675BPQX24	3/4"	24"
1675BPQX36	3/4"	36"
1675BPQX48	3/4"	48"
1675BPQX60	3/4"	60"
1675BPQX72	3/4"	72"
16100BPQX36	1"	36"
16100BPQX48	1"	48"
16100BPQX60	1"	60"
16100BPQX72	1"	72"

## Gas Outlet Box



Part Number: NG-OUTLET-1

PART NUMBER	DESCRIPTION
556#1793	3/8" x 12' with Quick Connect
556#1791	1/2" x 12' with Quick Connect



Part Number: NG-OUTLET-2

## Outlet Box



Universal 1 5/16" M. Acme/F. POL Outlet Connection  
 Universal 1/2" FNPT Inlet Connection  
 Universal Mounting Hinge  
 For use with 0-250 PSI Inlet Pressure  
 Weather resistant high density polyethylene case

SINGLE PART NUMBER	PART NUMBER	COLOR
ME951IVY	ME952IVY	Ivory
ME951BLK	ME952BLK	Black
ME951GRY	ME952GRY	Gray



**Twin Stage Regulator**



The first stage features a lever arm design that improves both the efficiency and regulation. Combined with the second stage regulator, the overall performance assures even smoother and more continuous flow of gas to all appliances.

**SPECIFICATIONS:**

- Inlet: 1/4" FPT
- Outlet: 3/8" FPT
- 160,000 BTU Capacity

PART NUMBER	DESCRIPTION
290-GR550	Vent Over Outlet
299-GR9959	9 O'clock Vent

**Automatic Changeover Regulators**



Combination automatic changeover two-stage regulator. Suitable for home and mobile homes. Empty containers may be replaced without interruption of gas service.

**SPECIFICATIONS:**

- 130,000 BTU Capacity - Reserve Cylinder
- Inlet: 1/4" Female Inverted Flare
- Outlet: 3/8" FPT

PART NUMBER	DESCRIPTION
254-GR9984	Regulator

**Single Stage Regulators**

**Single-Stage Regulators**

230-00 low pressure, ideal for grills, small stoves and camping appliances when installed in compliance with N.F.P.A. Standards.

**SPECIFICATIONS:**

- 140,000 BTU Capacity
- Inlet: 1/4" FPT
- Outlet: 3/8" FPT



230-GR800 Drip Lip Vent  
230-GR856 with POL installed



230-#1326  
230-GR866  
G-1851-A03 Handwheel



**Need a regulator with larger capacity? RegO regulators fit the bill.**

## High Pressure LP Gas Regulators

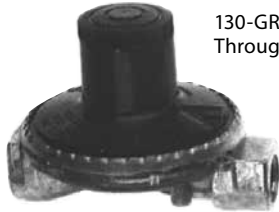

130-GR610B Straight Through 10 PSI

### SPECIFICATIONS:

- Inlet: 1/4" FPT
- Outlet : 1/4" FPT
- Dimensions: 2 1/2"H, 2 5/8"W, 3 1/8L, Wt. 8 OZ
- Non Relieving
- Underwriters Laboratories Listed



350-00 0-30PSI ADJ

## Rubber Pigtails



360° of confidence

The flexible thermoplastic hose material used on pigtails and high pressure hoses is rated at 350 lbs working pressure and has a burst rating of 1750 PSI. End fittings are secured in place with proven, four jaw crimped, copper rings. Together they offer an assembly that meets all applicable UL and C.S.A. tests and requirements. All assemblies up to 60 inches in length are dual (UL and CSA Listed).

### 1/4" I.D. Thermoplastic Pigtail POL x 1/4" Inverted Flare

PART NUMBER	LENGTH	PART NUMBER	LENGTH
40403-15	15"	40403-36	36"
40403-20	20"	40403-48	48"
40403-24	24"	40403-60	60"
40403-30	30"		



40403-15-9 Fullflow POL X 1/4" Inverted Flare



S42CC Hose End Conversion Fitting 1/4" Female Inverted Flare X 1/4" MPT

### Flexible Pigtail

Type 1 ACME x 1/4" inverted flare  
Part Number: 40408-15



### Flexible Pigtail

Type 1 ACME x 1/4" MPT  
Part Number: 40409-15



## Regulator Covers

### H-200P 2nd Stage Regulator Cover



## Brackets



PART NUMBER	DESCRIPTION
240-9900	Z-Mounting Bracket Pre-drilled to attach to all Marshall Brass Regulators horizontally or vertically. Allows the regulator to be mounted from the front to any surface.

Don't forget to check out our *Patio and Outdoor Products* catalog for a great selection of gas grills.

### UL and C.S.A. Listed Hose Assemblies



Thermoplastic hose assemblies are available in 1/4" and 3/8" I.D. sizes only. The hose has a working pressure of 350 PSI with a 1750 PSI burst rating. All assemblies up to 60 inches in length are dual (UL and C.S.A.) listed.

360° OF CONFIDENCE

#### 3/8" I.D. Assemblies 3/8" M.P.T. x 3/8" Female Flare

PART NUMBER	LENGTH	PART NUMBER	LENGTH
42610-24	24"	42610-40	40"
42610-30	30"	42610-48	48"
42610-36	36"		

#### 3/8" I.D. Assemblies 3/8" M.P.T. x 1/2" Female Flare

PART NUMBER	LENGTH	PART NUMBER	LENGTH
42611-24	24"	42611-40	40"
42611-30	30"	42611-48	48"
42611-36	36"		

#### 1/4" I.D. Assemblies 3/8" M.P.T. x 3/8" Female Flare

PART NUMBER	LENGTH	PART NUMBER	LENGTH
42410-24	24"	42410-48	48"
42410-36	36"		

#### 1/4" I.D. Assemblies 3/8" Female Flare x Both Ends

PART NUMBER	LENGTH	PART NUMBER	LENGTH
42413-20	20"	42413-48	48"
42413-24	24"	42413-60	60"
42413-36	36"		

#### 3/8" I.D. Assemblies 3/8" Female Flare x Both Ends

PART NUMBER	LENGTH	PART NUMBER	LENGTH
42613-12	12"	42613-48	48"
42613-24	24"	42613-60	60"
42613-36	36"	42613-144	144"

### Adapter Hoses

The 40407 adapter hose has a safe, convenient, "user friendly" design that makes it ideal for hooking up portable, high pressure propane appliances such as camp stoves, lanterns, and table top grills to large cylinders.



40407-60  
40407-144  
Appliance Adapter Hose  
For Carded Add-9



42421-60  
42421-144  
Extend-A-Flow Hose  
For Carded Add-9



538-00  
Extend-A-Flow Plus with  
QCC Type 1 Connection



535-00  
Extend-A-Flow Kit  
with POL Connection

The 42421 Extend-A-Flow adapter hose is also designed to thread directly into the opening on the high pressure appliance. However, its other end is engineered to go into one of four adapter tee fittings. One end is 1" 20, male swivel for the appliance and the other is 1" 20, female swivel for the tee fitting connection.

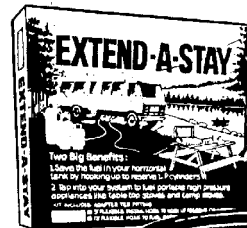

#### Extend-A-Stay

536-00 Standard Kit with 5 ft. hose and tee fitting

537-00 Deluxe Kit with tee fitting, 12 ft. hose and 5 ft. hose

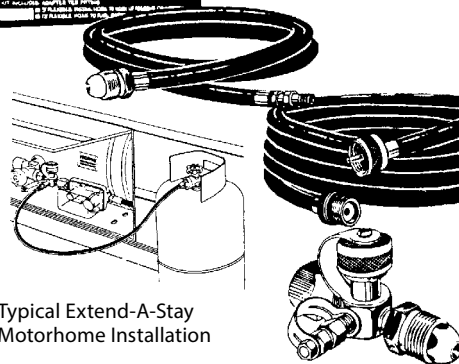

Typical Extend-A-Stay  
Motorhome Installation



We have more POL fittings on page 14 in Regulators and 209 in Outdoor Products.

## Fittings

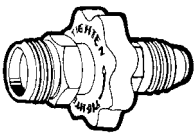

**Soft Nose Handwheel POL x 1" 20 Male Adapter**

**G-475** 1" 20 male x 60 orifice soft nose handwheel POL



**G-487** Reserve Cylinder Adapter  
1" 20 female x female POL

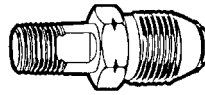

**Soft Nose POL Assembly**

**G-1638** 1/4" MPT x 60 orifice soft nose POL

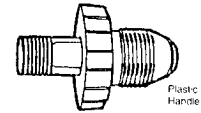

**Soft Nose Handwheel POL**

**G-1654** 1/4" MPT x soft nose full flow POL with handwheel



**G-1700** 1/4" female inverted flare x 1/4" female inverted flare x 1/4" MPT

**G-1701** W/O check



**G-413** TEE-FOR-TWO

**G-1641** 1/4" MPT x excess flow soft nose POL

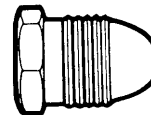

**Brass POL Plug**  
**G-1691**

**G-1653** 1/4" MPT x excess flow soft nose POL with handwheel

**G-1653A** Same as G-1653 but with brass handwheel

**G-1645** 9/16" 18 LH x excess flow soft nose POL with handwheel



**G-203** Hose coupling 9/16" 18 LH both ends



**G-415** EXTEND-A-FLOW TEE

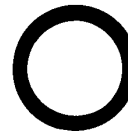

**POL O-Ring**  
**G-1653-3** Replaces O-ring for soft nose POL

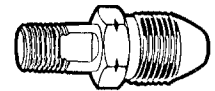

**POL Assembly**

**G-1675** 1/4" MPT x full flow POL 7/8" hex nut

**G-1685** 1/4" MPT x full flow POL 1 1/8" hex nut

**G-1690** 1/4" MPT x excess flow POL 7/8" hex nut

**G-1692** 1/4" MPT x excess flow POL 1 1/8" hex nut

**G-1689** 9/16" 18 LH x excess flow POL 7/8" hex nut

**G-1687** 9/16" 18 LH x excess flow POL 1 1/8" hex nut

**G-1650** 9/16" 18 LH x full flow POL 7/8" hex nut

**G-1651** 9/16" 18 LH x full flow POL 1 1/8" hex nut



**G-491** 3/8" male flare x 1" 20 male



**G-492** 1/4" female pipe thread x male 1" 20 thread with O-ring

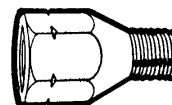

**Female POL**  
**G-415-2** Female POL x 1/4" MPT



**G-488** 1/4" MPT x female 1" 20



**G-414** ADD-A-TEE

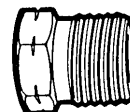

**POL Nut**

**G-1643** Standard 7/8" hex nut

**G-443-1** Heavy duty 1 1/8" hex nut



**G-493** 9/16" 18 LH X 1" 20 male thread with check valve and O-ring

**G-494** Same as above less check valve

**G-417** 1/4" MPT x 1" 20 male thread with check valve and O-ring



**G-212** 9/16" 18 LH X 1/4" MPT



**G-420** EXTEND-A-STAY TEE

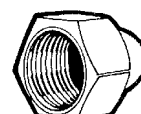

**Brass POL Cap**  
**G-1699**

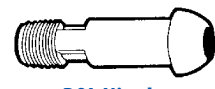

**POL Nipple**

**G-1675-1** Standard POL Nipple with wrench flats 1/4" MPT x full flow

**G-1648-1** Short POL nipple with hex flats on nose 1/4" MPT x full flow

## Gauges



MSCP-SG2.5-5



MSCP-SGC2-15



MSCP-SGL2.5-30

### STEEL CASE

PART NUMBER	RANGE	INLET	SIZE	CASE
MSCP-SG2.5-5	0-5#	1/4 Bottom	2 1/2"	STEEL
MSCP-SG2-15	0-15#	1/4 Bottom	2"	STEEL
MSCP-SG2-15-1/8	0-15#	1/4 Bottom	2"	STEEL
MSCP-SG2-30	0-30#	1/4 Bottom	2"	STEEL
MSCP-SG2-60	0-60#	1/4 Bottom	2"	STEEL
MSCP-SG2-100	0-100#	1/4 Bottom	2"	STEEL
MSCP-SG2-160	0-160#	1/4 Bottom	2"	STEEL
MSCP-SG2-200	0-200#	1/4 Bottom	2"	STEEL
MSCP-SG2.5-200	0-200#	1/4 Bottom	2"	STEEL
MSCP-SG2-300	0-300#	1/4 Bottom	2"	STEEL
MSCP-SG2-300-1/8	0-300#	1/4 Bottom	2"	STEEL
MSCP-SG2-400	0-400#	1/4 Bottom	2"	STEEL
MSCP-SGC2-15	0-15#	1/4 Back	2"	STEEL
MSCP-SGC2-30	0-30#	1/4 Back	2"	STEEL
MSCP-SGC2-60	0-60#	1/4 Back	2"	STEEL
MSCP-SGC2-100	0-100#	1/4 Back	2"	STEEL
MSCP-SGC2-160	0-160#	1/4 Bottom	2"	STEEL
MSCP-SGC2-200	0-200#	1/4 Back	2"	STEEL
MSCP-SGC2-300	0-300#	1/4 Back	2"	STEEL
MSCP-SGC1.5-300-1/8	0-300#	1/8 Back	2"	STEEL
MSCP-SGC2-400	0-400#	1/4 Back	2"	STEEL
MSCP-SGC2.5-400	0-400#	1/4 Back	2"	STEEL
MSCP-SG4.5-300	0-300#	1/4 Bottom	4 1/2"	STEEL
MSCP-SG4.5-400	0-400#	1/4 Bottom	4 1/2"	STEEL
MSCP-SG-2.5-35INWC	0-35WC	1/4 Bottom	2 1/2"	STEEL

### STEEL CASE - LIQUID

PART NUMBER	RANGE	INLET	SIZE	CASE
MSCP-SGL2.5-15	0-15#	1/4 Bottom	2 1/2"	STEEL
MSCP-SGL2.5-30	0-30#	1/4 Bottom	2 1/2"	STEEL
MSCP-SGL2.5-60	0-60#	1/4 Bottom	2 1/2"	STEEL
MSCP-SGL2.5-300	0-300#	1/4 Bottom	2 1/2"	STEEL
MSCP-SGL2.5-400	0-400#	1/4 Bottom	2 1/2"	STEEL



MSCP-BGC2-15

### BRASS CASE

PART NUMBER	RANGE	INLET	SIZE	CASE
MSCP-BG2-15	0-15#	1/4 Bottom	2"	BRASS
MSCP-BG2-30	0-30#	1/4 Bottom	2"	BRASS
MSCP-BG2-60	0-60#	1/4 Bottom	2"	BRASS
MSCP-BG2-100	0-100#	1/4 Bottom	2"	BRASS
MSCP-BG2-300	0-300#	1/4 Bottom	2"	BRASS
MSCP-BG2-300-1/8	0-300#	1/8 Bottom	2"	BRASS
MSCP-BG2-400	0-400#	1/4 Bottom	2"	BRASS
MSCP-BGC2-15	0-15#	1/4 Bottom	2"	BRASS
MSCP-BGC2-30	0-30#	1/4 Bottom	2"	BRASS
MSCP-BGC2-60	0-60#	1/4 Bottom	2"	BRASS
MSCP-BGC2-100	0-100#	1/4 Bottom	2"	BRASS
MSCP-BGC2-300	0-300#	1/4 Bottom	2"	BRASS
MSCP-BGC2-400	0-400#	1/4 Bottom	2"	BRASS

## Pressure Gauge Snubber

Pressure snubber protects gauge from damaging surges and moderates pulsating at the gauge.

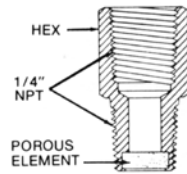

PART NUMBER	DESCRIPTION
B25-G	1/4" X 1/4" Pressure Snubber, Filter
1449	1/4" X 1/4" Pressure Snubber, 54# Drill

## Pressure Gauge Adapter

1/2" MNPT x 1/2" FNPT adapter with 1/4" gauge opening for indicating outlet pressure of a first stage regulator.

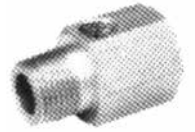

PART NUMBER	DESCRIPTION
J595	1/2" Gauge Adapter
1494-1	1/2" Gauge Adapter

## Presto-Tap Universal Tech Kit



Universal Service-Tech-Kit

## Pressure Tap Adapter



MSCP-TRV

## Replacement Dials



5-01813



2701AGTM



5-1951



5-01852



2733U-CV



3181-01749

PART NUMBER	TANK	REMOTE READY	SETTING	TYPE	GUIDE HOLE	READS
5-01813	Underground Horizontal	Yes	2 Screw	JR	N/A	5%-95%
2700CV	Underground Horizontal	No	Drop In	JR	94%	5%-94%
130024	Underground Horizontal	Yes	Drop In	JR	10%	5%-94%
2701AGTM	Aboveground Horizontal	Yes	Drop In	JR	5%	5%-94%
2701CV	Aboveground Horizontal	No	Drop In	JR	5%	5%-94%
5-01749	Aboveground Horizontal	Yes	2 Screw	JR	N/A	5%-95%
5-00001	Aboveground Horizontal	No	2 Screw	SR	N/A	5%-95%
5-01835	420# Vertical	Yes	2 Screw	JR	N/A	10%-80%
5-1951	420# Vertical	Yes	Snap	JR	N/A	10%-80%
2765CVLP	420# Vertical	No	Drop In	JR	80%	10%-80%
5-00435	420# Vertical	Yes	2 Screw	SR	N/A	10%-80%
130039	200# Vertical	Yes	Drop In	JR	5%	5%-85%
5-01852	200# Vertical	No	2 Screw	JR	N/A	5%-85%
2722CU	200# Vertical	No	Drop In	JR	85%	5%-85%
G13088	100# Vertical	No	Snap On	JR	N/A	10%-80%
5714SO2591	Forklift Cylinders	No	Snap On	JR	N/A	E-1/4-1/2-F
2733U-CV	Forklift Cylinders	No	Drop In	JR	7%	H=13%-40% V=7%-20%
5-01789	Forklift Cylinders	No	2 Screw	JR	N/A	E-1/4-1/2-3/4-F
5343SO1992	Forklift Cylinders	No	2 Screw	JR	N/A	H=1/8-1/4-3/8 V=1/8-1/4-3/8
3181-01749	Universal Dials	No	Drop In	JR	N/A	5%-95%
3180-17001	Universal Dials	No	2 Screw	SR	N/A	5%-95%

## Universal Dial Kit

For obsolete junior or senior gauges. Complete instructions included with each kit. Fits any LPG float gauge.



PART NUMBER	DESCRIPTION
3181-01749	Junior Universal Dial Kit
3180-17001	Senior Universal Dial Kit

## Screws and Gaskets



PART NUMBER	DESCRIPTION
MSCP-M40-414S	Junior Head Bolt
40-415S	Senior Head Bolt
40-416	Dial Screw
MSCP-15-007	Junior Gauge Gasket
MSCP-15-004	Senior Gauge Gasket

## Replacement Float Gauges for ASME Tanks

### Trinity Underground Tanks

TANK SIZE	SQUIBB TAYLOR JR 4 BOLT		REPLACEMENT DIAL
	14" RISER	28" RISER	
120 WG	JB213B	JB340A	5-01813
250 WG	JB251A	JB376A	5-01813
320 WG	JB251A	JB376A	5-01813
500 WG	JB277A	JB404D	5-01813
1000 WG	JB297A	JB424C	5-01813
2000 WG	-	JB450D	5-01813

### Trinity Aboveground Aboveground/Underground Tanks

TANK SIZE	SQUIBB TAYLOR GAUGES	REPLACEMENT DIAL
	1" MNPT	
120 WG	HA130A	5-01813
250 WG	HA162A	5-01813
320 WG	HA162A	5-01813
500 WG	HA194A	5-01813
1000 WG	HA210A	5-01813
2000 WG	-	5-01813

### American Welding Aboveground and Aboveground/Underground Tanks

TANK SIZE	SQUIBB JR SCREW		REPLACEMENT DIAL
	1 1/4" MNPT	1" MNPT	
120 GAL	TA130A	HA130A	5-01749
150 GAL	TA130A	HA130A	5-01749
250 GAL	TA160A	HA160A	5-01749
325 GAL	TA160A	HA160A	5-01749
500 GAL	TA194A	HA194A	5-01749
1000 GAL	TA210A	HA210A	5-01749
1450 GAL	TA240A	HA240A	5-01749
1990 GAL	TA240A	HA240A	5-01749

### American Welding Underground Tanks

TANK SIZE	SQUIBB JR 4 BOLT		REPLACEMENT DIAL
	11 1/4" RISER	18 1/4" RISER	
120 GAL	JB232A	JB302A	5-01813
150 GAL	JB232A	JB302A	5-01813
250 GAL	JB262A	JB332A	5-01813
325 GAL	JB262A	JB332A	5-01813
500 GAL	JB296A	JB370F	5-01813
1000 GAL	JB316C	JB386D	5-01813
1450 GAL	-	JB400H	5-01813
1990 GAL	-	JB400H	5-01813



**Bulk Storage Gauges**

**Rochester Magnetel**

The 6340 series Magnetel Liquid Level Gauges are designed to accurately determine the percentage of tank volume in stationary storage applications. Gauges are U.L. listed for LP Gas and NH3 service. These models incorporate a zinc-plated steel counterbalance and a Alinco magnet with head and all other wetted parts made from 300 stainless steel. Gauges include gasket and set of 8 mounting studs and nuts.

PART NUMBER	DESCRIPTION
R6342-11-108	8" Dial, End Mount 108" Tank
6342-11-130	8" Dial, End Mount 130" Tank
6342-11-84	8" Dial, End Mount 84" Tank
22-29	2 1/2" M.NPT. Adapter*
5305	2" M.NPT Adapter
R0044-0403	Nut for Magnetel Bolt
R0056-00404	1/2" Magnetel Mounting Bolt
R0003-00005	8" Replacement Dial Glass
R0015-00010	Gasket, 8" Glass (2 required)
R0093-00403	8" Dial Chamber Mounting Bracket
R0015-00019	Spiral Wound Gasket

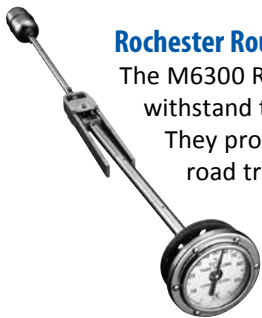

**Rochester Rough Rider**

The M6300 Rough Rider series gauges are designed to withstand the vibration and shock of mobile service. They provide unsurpassed service life in over-the-road transport of LP Gas and NH3 liquids. The M6300 provides continuous reading of tank contents in percentage of tank capacity. They include a zinc-plated steel counterbalance and an Alinco magnet with all other wetted parts made of 300 stainless steel.

PART NUMBER	DESCRIPTION
M6339-11-72	4" Dial, 72" Truck Tank
M6339-11-79	4" Dial, 79" Truck Tank
5-1262	Replacement 4" Dial Chamber
22-29	2 1/2" M.NPT. Adapter
5305	2" M.NPT Adapter*
R009300001	4" Dial Chamber Mounting Bracket
R0015-00451	Gasket, 4" Glass
R0015-00019	Spiral Wound Gasket
R0040-00413	4" Dial Screw

**Squibb Master Visible**

These float gauges feature a large 10" hermetically sealed dial face with a chrome retainer. Extremely heavy duty construction for storage tanks. Other sizes available. Gauges include spirotalllic gasket and 8 mounting bolts.

PART NUMBER	DESCRIPTION
MD360C	10" Dial End Mount 108" Tank
MD430B	10" Dial End Mount 130" Tank
130219	Mounting Bolts
5305	2" M.NPT Adapter*
130035	Replacement 10" Dial
130040	Spirotalllic Gasket
130201	10" Replacement Glass

\* Requires specially ordered gauge with 2" dial float bulb.

**The Roadmaster from Squibb Visible**

Uniquely designed to withstand the tough shock and vibration associated with mobile service. Incorporates a special spring designed to substantially reduce stress on conventional float type gauges on mobile applications. 4" easy viewing dial. Ideal for new or replacement installations.

TANK DIAMETER	PART NUMBER	DESCRIPTION
72" Diameter Mobile Tank	RM1833	72" Diameter Mobile Tank
84" Diameter Mobile Tank	RM2438	84" Diameter Mobile Tank

*Underground Storage Tank Gauges Available*

## RegO Rotogages

*These Components Must Be Ordered Separately*

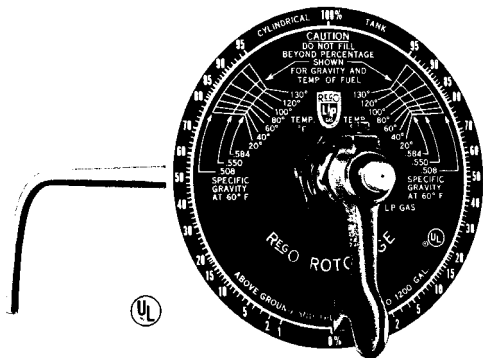

MODEL NUMBER	FOR TANKS	GAUGE	TUBE	DIAL
9091RM24	30-45"	A9091R	A9091-M24.0	A9091-18LX
9092RM36	46-61"	A9092R	A9091-M36.0	A9091-18LX
90903TSM48*	62-79"	A9093TS	A9091M48.0	A9091-18LX
9093RSM48**	62-79"	A9093RS	A9091M48.0	A9091-18LX
9094TSM60*	80-99"	A9094TS	A9091-M60.0	A9091-18LX
9094RSM60**	80-99"	A9094RS	A9091-M60.0	A9091-18LX
9095TSM72*	100-147"	A9095TS	A9091-M72.0	A9091-18LX
9095RSM72**	100-147"	A9095RS	A9091-M72.0	A9091-18LX

\*\*TSM – supported design, mobile or stationary

\*\*RSM – stationary design only"

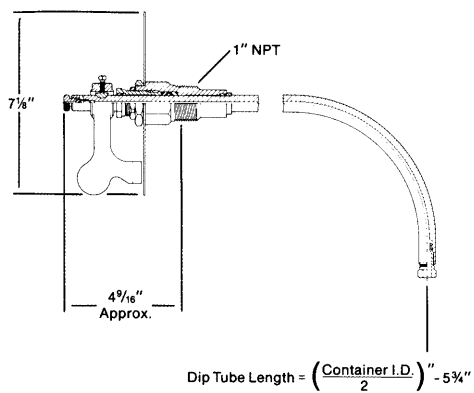

### RegO Rotogage Replacement Parts

PART NUMBER	DESCRIPTION
A 3163-6	Stem Assembly
2092-13	Packing (2-Required)
8092-15	Packing Gland Nut
A9091-61T	Body Bushing (2 Required)
A9091-18LX	Dial (LP Only)

These parts are usable in all gauges except those beginning with a part number of TA.

## Container Thermometers



The 2-inch diameter dial is calibrated - 40° to 120° F. and - 40° to 50°C. The thermometers are dust-proof and moisture-proof.

TYPE NUMBER	CONTAINER CONNECTION	STEM LENGTH
MSCP-SSBT-3-4	1/2" MNPT	4"
MSCP-SSBT-3-6	1/2" MNPT	6"

Thermowell for MSCP-SSBT-3-6



Part Number: 75THR2R045CC

## Tank Car Thermometer



-30° to +120° Range, 12" Long

-30°F + 120°F Range

Thermometer Only – Part Number: MSCP-A12

Thermometer & Armor – Part Number: MSCP-A12-A

## Red Dragon Torches

Kit contains torch, hose, POL fitting, needle valve and spark lighter. Roofing and hand torch kits also contain regulator and gauge.



KIT NUMBER	TORCH ONLY	BTU/HR	OVERALL LENGTH	TYPE
VT2-23C	-	100,000	27 1/2"	Vapor
RT1-1/2-10C	RT1-1/2-10	50,000	15"	Roofing
VT1-1/2-12C	VT1-1/2-12	50,000	15"	Vapor
RT2-1/2-20C	RT2-1/2-20	200,000	29"	Roofing
VT2-1/2-30C	VT2-1/2-30	200,000	33"	Vapor
VT3-30C	VT3-30	500,000	33 1/2"	Vapor
VT3-60C	VT3-60	500,000	65"	Vapor
RT-COMBO	Kit RT1-1/2-10, RT2-1/2-20, quick connect, regulator, hose, POL, spark ignitor			
V-880P	Squeeze valve with adjustable pilot			

## Nu-Way Torches

### Cast Iron Head, Pipe Handle Adjusting Valve



PART NUMBER	BTU/HR	LENGTH
5-V	500,000	24"

*Whatever the job is we've got the torch to handle it.  
From 26,000 BTUs to a whopping 500,000 BTUs.*

## Manchester Propane Handburners



PART NUMBER	DESCRIPTION
8012	8 ft weed burning torch (similar design to 8061)
8061*	3 ft torch, hose, POL power jet 750,000 BTU
8062*	2 ft torch, hose, POL handboy 500,000 BTU
8069	Replacement handle

\* Bubble pack kit

## Gas Match Lighters



### GM-3X

15" flexible nozzle bends into any shape, never blows out.  
Part Number: GM-3X



### GM-3

Long continuous spark, battery operated. Refillable.  
Part Number: GM-3



### GM-12X

Multi-sparker continuous ignition piezo electric gas ignitor. 20" flexible ignition pipe. Uses no butane.  
Part Number: GM-12X



### GM-4

Medium refillable, white.  
Part Number: GM-4

### Multi-Fill Butane

Part Number: REFILL  
2.75 oz.



Same as above with 25" flexible ignition pipe.  
Part Number: GM-12XE



*Everybody needs a Buddy. The Mr. Buddy heater uses revolutionary new heating technology. Check it out!*



## Mr. Heater / Propane Camping Accessories



Instant Heat. Anytime! Anywhere!

- Safe for indoor and outdoor use
- 4,000 and 9,000 BTUs
- Heats up to 250 square feet
- ODS system
- Uses 1lb. disposable cylinder (not included) 3 to 6 hours
- AGA approved
- Optional hose with connector for use on 20lb. cylinder

Part Number: MH9B

Part Number: MH18B 18,000 BTU



## Mr. Heater / Propane Camping Accessories

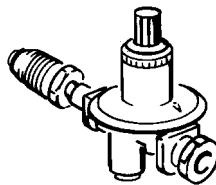

### High Pressure Regulator with POL

Most commonly used on torches, fish cookers, smokers or other high pressure appliances.

Part Number: F273719

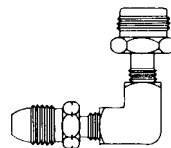

### 90 Degree Elbow (POL x 1"-20 Throwaway Cylinder Male)

Allows appliances designed for use on throwaway cylinder.

Part Number: F273760

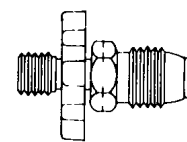

### LP Gas Cylinder Adapter with Handwheel

Part Number: F273758

Allows appliances designed for use on throwaway cylinders, and with a hose/regulator assembly.

LP Gas Cylinder Adapter without Handwheel

Part Number: F276132

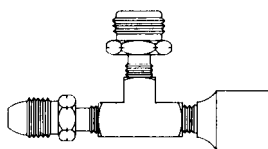

### LP Gas Adapter Tee

Conveniently use your camper/trailer propane supply for lanterns, or tabletop barbecue at parks, campsites, rest stops, etc.

Part Number: F273751



### Propane Cylinder "Y" with Handwheel (2 1" - 20 Outlets)

Allows two appliances to be hooked up to a 20lb cylinder.

Part Number: F271715

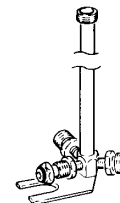

### 30" Distribution/Lantern Post (3 1" - 20 Outlets)

Use with F273710 - 11 hose assembly. Hook up 3 appliances to a single refillable 20lb propane cylinder.

Part Number: FL271731

## Mr. Heater / Propane Camping Accessories

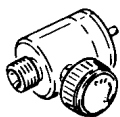

### Post Adapter Valve

Allows use of 9/16" left hand hose assembly.

**Part Number: F271725**



### Brass Cap

Fits all distribution posts, adapter tees, etc.; keeps dust and dirt from inside fittings.

**Part Number: F276400**

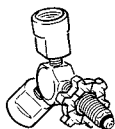

### Propane "Y" Female Adapter with Handwheel (2-Female POLs x POL)

Allows two appliances to be hooked up to a bulk cylinder. (Use with F273701-02.)

**Part Number: F271735**

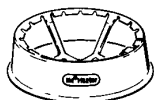

### TankFoot Tank Stabilizer

Fits 20lb, 30lb, and 40lb tanks; reduces risk of tipping cylinder while transporting in your RV, pick-up, car etc.

**Part Number: TF-01**

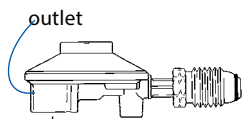

### Low Pressure Regulator with POL (straight) (POL Inlet x 3/8" FP Outlet)

11" WC low pressure regulator will operate barbecue grills and low pressure appliances.

**Part Number: F276136**

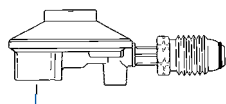

### Low Pressure Regulator with POL (90 degrees)

11" WC low pressure regulator designed with 90 degree angle; will operate all standard barbecue grills and appliances.

**Part Number: F273759**

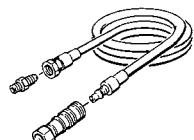

### 12' Natural Gas Patio Hose Assembly (3/8" Female Pipe Thread x 3/8" Male Flare Quick Connect/ Disconnect with Dust Plug and Cap)

Most commonly used on connecting natural gas barbecue grills attached to decks or patios to the supply from a house.

**Part Number: F273720**

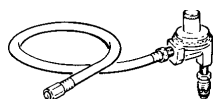

### 22" Universal Replacement Barbecue Hose and Regulator Assembly (POL x 3/8" Female Flare)

Fits most propane gas grills.

**Part Number: F271160**

As above with Type 1 QCC connection instead of POL

**Part Number: F271161**

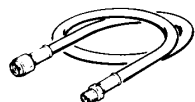

### 5' Hose Assembly (3/8" Female Pipe x 3/8" Male Pipe Thread)

Common assembly hose for hooking up low pressure appliances.

**Part Number: F276124**

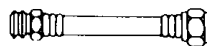

### 24" Universal Barbecue Hose Assembly (3/8" Male Pipe and 3/8" Female Flare)

Fits most standard barbecue gas grills.

**Part Number: F273716**

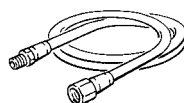

### 5' Hose Assembly (1/4" Male Pipe Thread x 1/4" Female Pipe Thread)

Most commonly used on weed burner, torch, fish cooker assembly.

**Part Number: F273717**

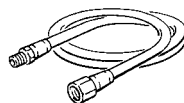

### 5' Propane Hose Assembly (1/4" Male Pipe Thread x 3/8" Female Flare)

Replaces most hose assemblies between regulator and fish cooker/smoker, torches, or other appliances.

**Part Number: F273707**

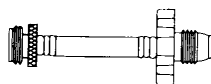

### Hose Assembly (Soft Nose Excess Flow POL with Handwheel x Swivel 1"-20 Male Throwaway Cylinder Adapter)

Mr. Heater's most popular hose; permits the use of larger propane cylinders on appliances designed for use with small disposable cylinders; convenient hand tightened swivel both ends.

**5' Hose Assembly Part Number: F273701**

**12' Hose Assembly Part Number: F273702**

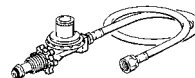

### Propane Hose/Regulator Assembly (Regulator with POL and Handwheel x 3/8" Female Flair)

Connects low pressure portable propane appliances to a 20 lb. cylinder.

**5' - Part Number: F273071**

**12' - Part Number: F273072**



### Hose Assembly (Swivel 1" - 20 Male Throwaway Cylinder Thread x Swivel 1" - 20 Female Throwaway Cylinder Thread)

Use with most distribution posts or "T" or "Y" connectors as well as 1 lb disposable cylinders.

**5' - Part Number: F273710**

**12' - Part Number: F273711**

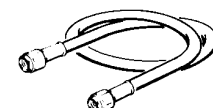

### 5' Appliance Extension Hose (9/16" - 18LH Thread, Female Fittings both ends)

Combine with Mr. Heater (F276154) nipple to make longer lengths;

use with F276129, F276130 to assemble F276122-23.

**Part Number: F276148**

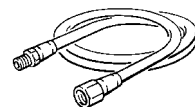

### 15' Propane Appliance Extension Hose Assembly (3/8" Male Pipe Thread x 3/8" Female Pipe Thread) (3/8" ID High Pressure Hose)

Use as an extension hose for portable propane appliances.

**Part Number: F271470**

As above with 1/4" Male Pipe Thread x 1/4" Female Pipe Thread (1/4" ID High Pressure Hose) - **Part Number: F271474**



Don't forget to check our **Patio and Outdoor Products** catalog for more items to enhance your summer.

## Mr. Heater Brass Fittings and Accessories

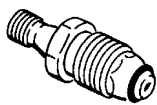

### POL with "O" Ring Seal without Handwheel (Brass POL Nut x 1/4" Male Pipe)

Fits all refillable propane cylinders and appliances with 1/4" female pipe inlet.

**Part Number: F276139**

As above with handwheel –

**Part Number: F273756**

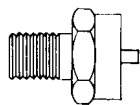

### 1" - 20 Female Throwaway Cylinder Adapter x 1/4" Male Pipe Thread

**Part Number: F273754**

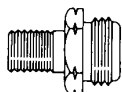

### 1" - 20 Male Throwaway Cylinder Adapter x 1/4" Male Pipe Thread

**Part Number: F273755**

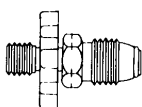

### 9/16" - 18 Left Hand POL With Restricted Flow with Handwheel

**Part Number: F273757**

As above without handwheel (wrench tighten)

**Part Number: F276129**



### 1" - 20 Male Throwaway Cylinder Adapter x 1/4" Female Pipe Thread

**Part Number: F276140**

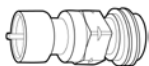

### Propane "Steak Saver" Adapter (Female Throwaway Cylinder Thread x Female P.O.L. and QCC-1)

Most commonly used with 1 lb. bottles to grills or distribution posts to grills.

**Part Number: F276171**



### 9/16" - 18 Left Hand Male Fittings

1/4" Male Pipe x 9/16" - 18 Left Hand Male

**Part Number: F276152**

3/8" Male Pipe x 9/16" - 18 Left Hand Male

**Part Number: F276153**

9/16" - 18 Left Hand Male Both Ends Male x 9/16"

**Part Number: F276154**

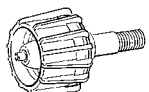

### Appliance End Fitting (Coupling Nut x 1/4" Male Pipe Thread)

For type 1 (QCC-1) gas grill systems. For appliances with 80,000 BTUs or less.

**Part Number: F276495**

## Quick Connectors



### Quick Connector (1/4" Female Pipe x 1/4" Excess Flow Male Pipe)

Use with F276134, F276139, and F276140. CSA certified; UL listed.

**Part Number: F276186**

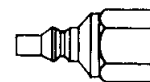

### Cylinder Fill Plug – Gas Mate II

Allows filling of cylinder with quick connect (Gas Mate II F276330) kit in use.

Please note: most LP filling stations have this plug.

**Part Number: F276329**

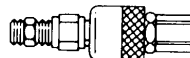

### Quick Connector (3/8" Female Pipe x 3/8" Male Pipe)

CSA certified; UL listed.

**Part Number: F276187**

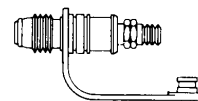

### Gas Mate II "Quick Connect" Kit (POL x Connection) (1/4" x plug)

Eliminates wrenches; fits on all refillable propane cylinders; provides plug in/plug out use of appliances such as torches, heaters, cookers, etc.

**Part Number: F276330**



### Propane or Natural Gas 1/4" Quick Connector with Shutoff Valve and Excess Flow Plug

(1/4" Male Pipe Thread x 1/4" Female Pipe Thread)

CSA certified; UL Approved.

**Part Number: F276181**

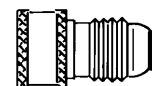

### Gas Mate II "Quick Connect" Socket (only) (POL x Quick Connect)

Quick connect for those spare refillable cylinders. See F276330 description above.

**Part Number: F276334**



### Propane or Natural Gas Connector (1/4" Male Pipe Thread x 1/4" Female Pipe Thread)

**Part Number: F276190**



### Propane or Natural Gas Matell Male Full Flow Plug (1/4" Male Pipe Thread x Male Plug)

For all appliances and all BTUs or high pressure appliances. Can be used with F276334

or can replace excess flow plug in F276186 and F276330 kits.

**Part Number: F276281**



### Propane or Natural Gas Male Excess Flow Plug

(1/4" Male Pipe Thread x Male Plug Quick Connect Fitting) for appliances 80,000 BTUs or less.

For use with F276334.

CSA certified; UL Approved

**Part Number: F276328**

## Mr. Heater Standard Replacement Parts

**Replacement Safety Shutoff** With orifice for all Mr. Heaters. **Part Number: F273116**

**Replacement 12.5" Thermocouple Lead** Fits most Mr. Heater models. **Part Number: F273117**

**Replacement Grid Screen Kit** For most Mr. Heaters. **Part Number: F273164**

**Hi-Med-Lo Regulator and Soft Nose Tank Union Assembly** For MH12T, MH24T, and MH42T. **Part Number: F273606**

**Hi-Med-Lo Regulator** For MH12, MH12C. **Part Number: F273607**

**Plastic Stand** For 16.4 oz. and 14.3 oz. disposable cylinders. **Part Number: F275217**

## Anhydrous Ammonia

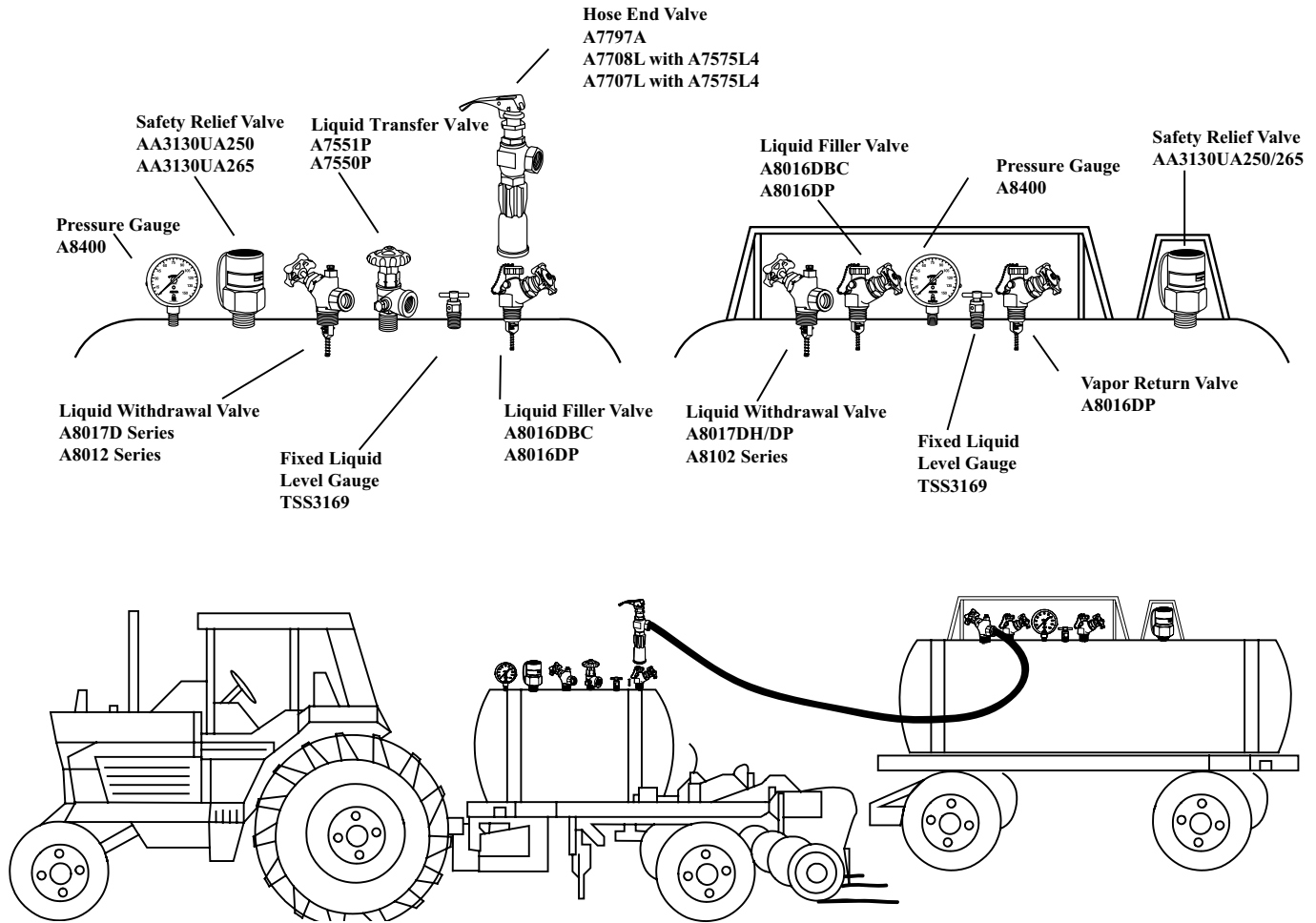

**Disclaimer:** The illustrations in this application guide are intended to inform a professional installer/system designer where our valves are generally installed on certain containers or applications. These illustrations are not intended for and must not be used for system design.

## Bobtail Delivery Trucks

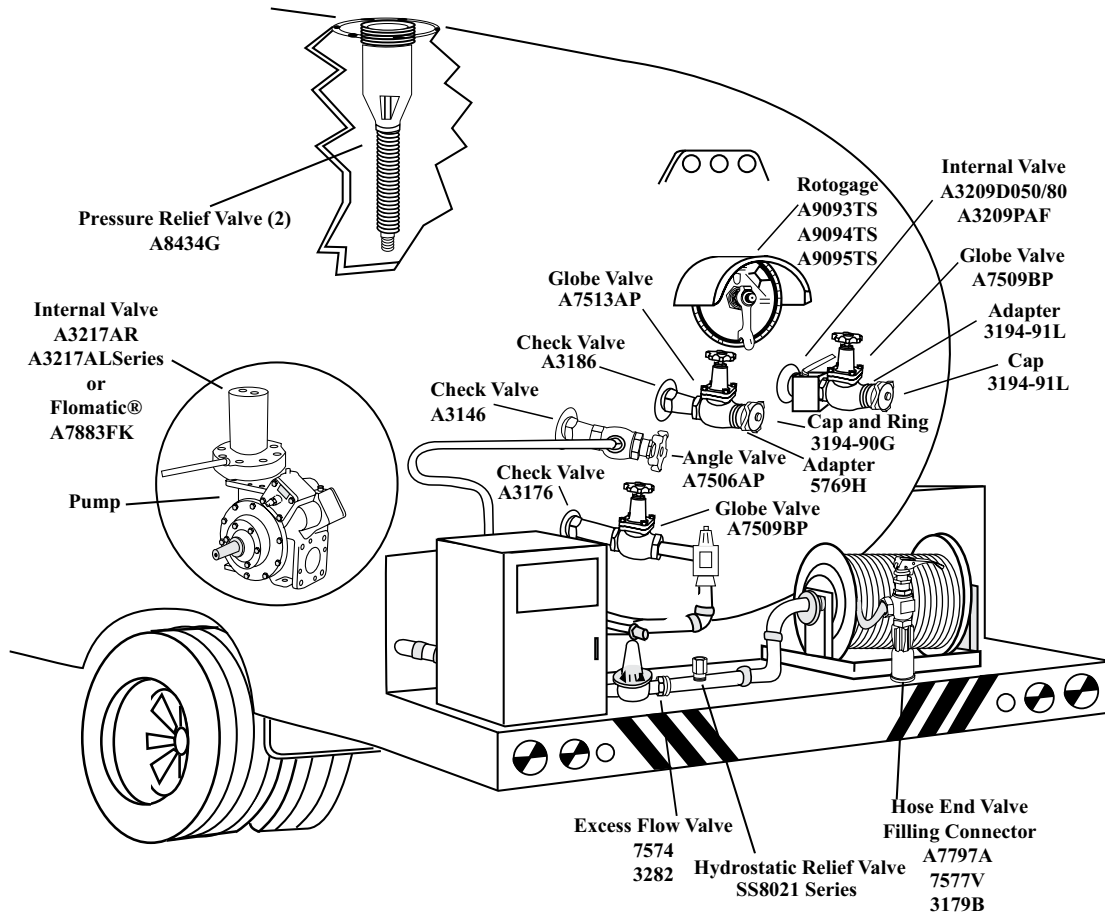

**Disclaimer:** The illustrations in this application guide are intended to inform a professional installer/system designer where our valves are generally installed on certain containers or applications. These illustrations are not intended for and must not be used for system design.



## Bulk Storage Plants

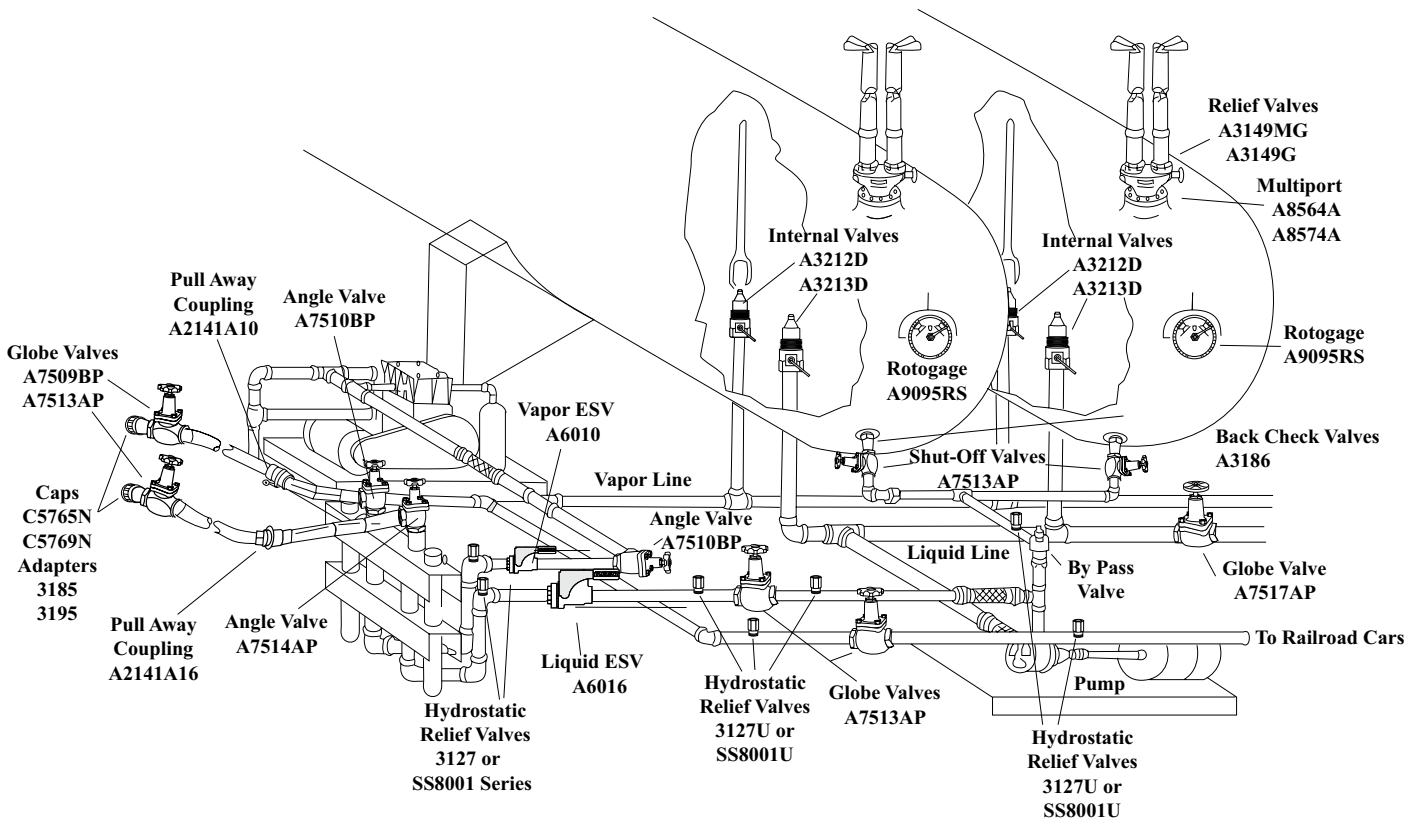

**Disclaimer:** The illustrations in this application guide are intended to inform a professional installer/system designer where our valves are generally installed on certain containers or applications. These illustrations are not intended for and must not be used for system design.

## Bulk Transport Trucks

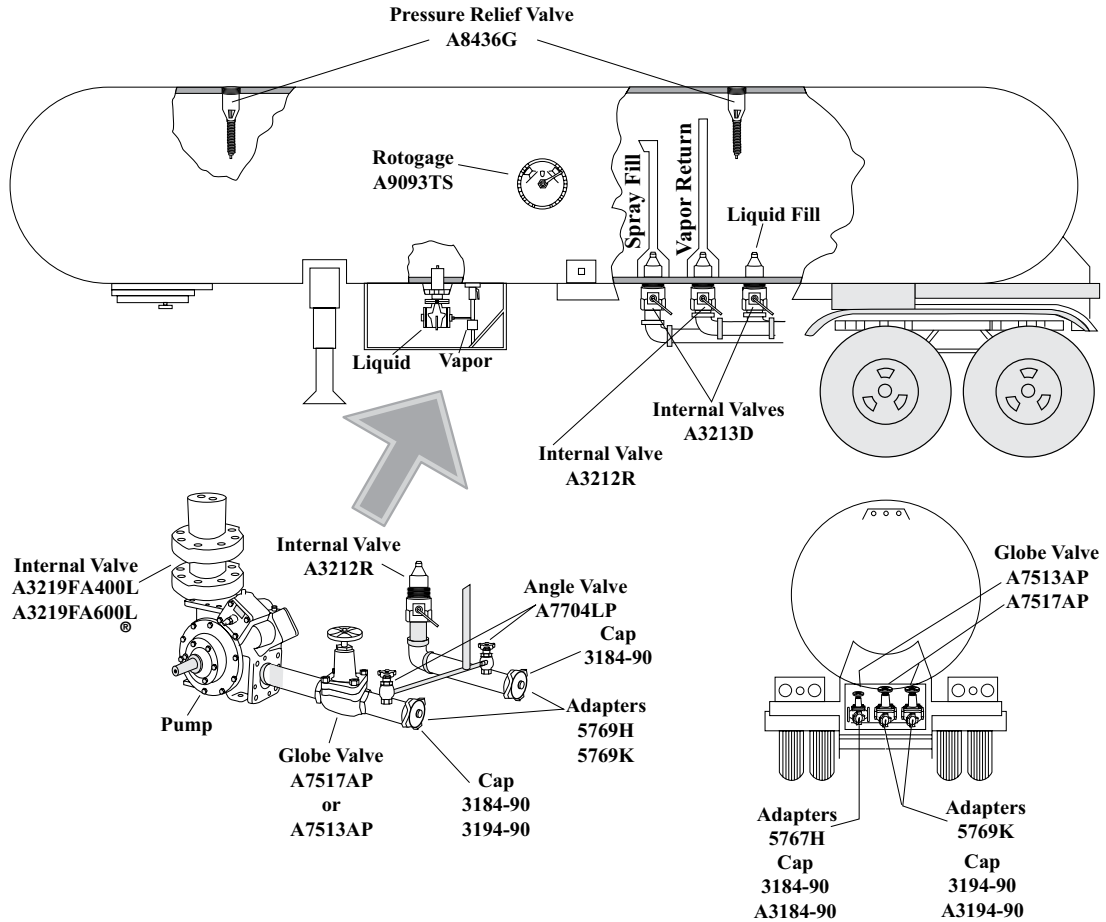

**Disclaimer:** The illustrations in this application guide are intended to inform a professional installer/system designer where our valves are generally installed on certain containers or applications. These illustrations are not intended for and must not be used for system design.

## Cylinder Valve Applications

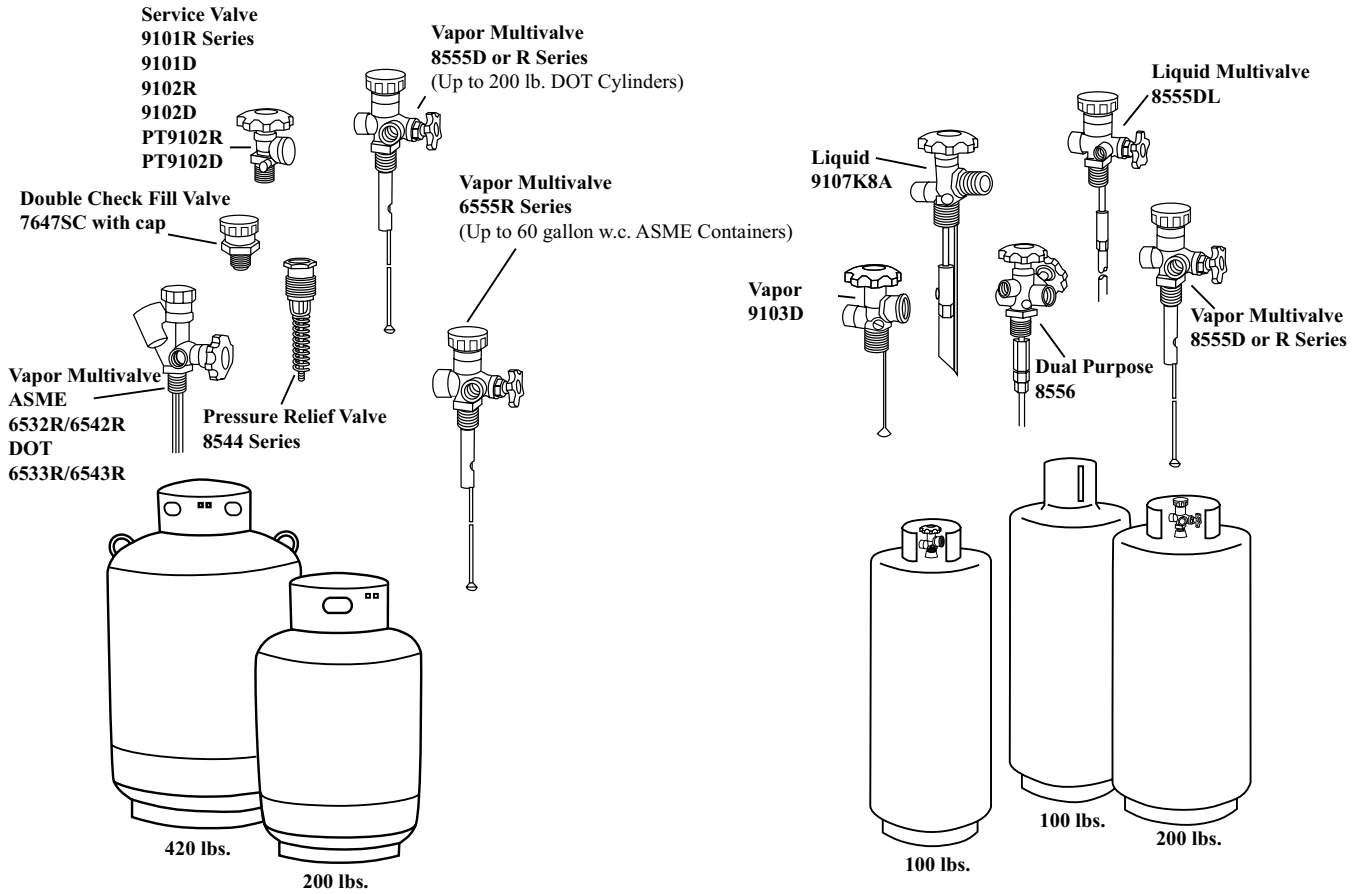

**Disclaimer:** The illustrations in this application guide are intended to inform a professional installer/system designer where our valves are generally installed on certain containers or applications. These illustrations are not intended for and must not be used for system design.

## Domestic Installations

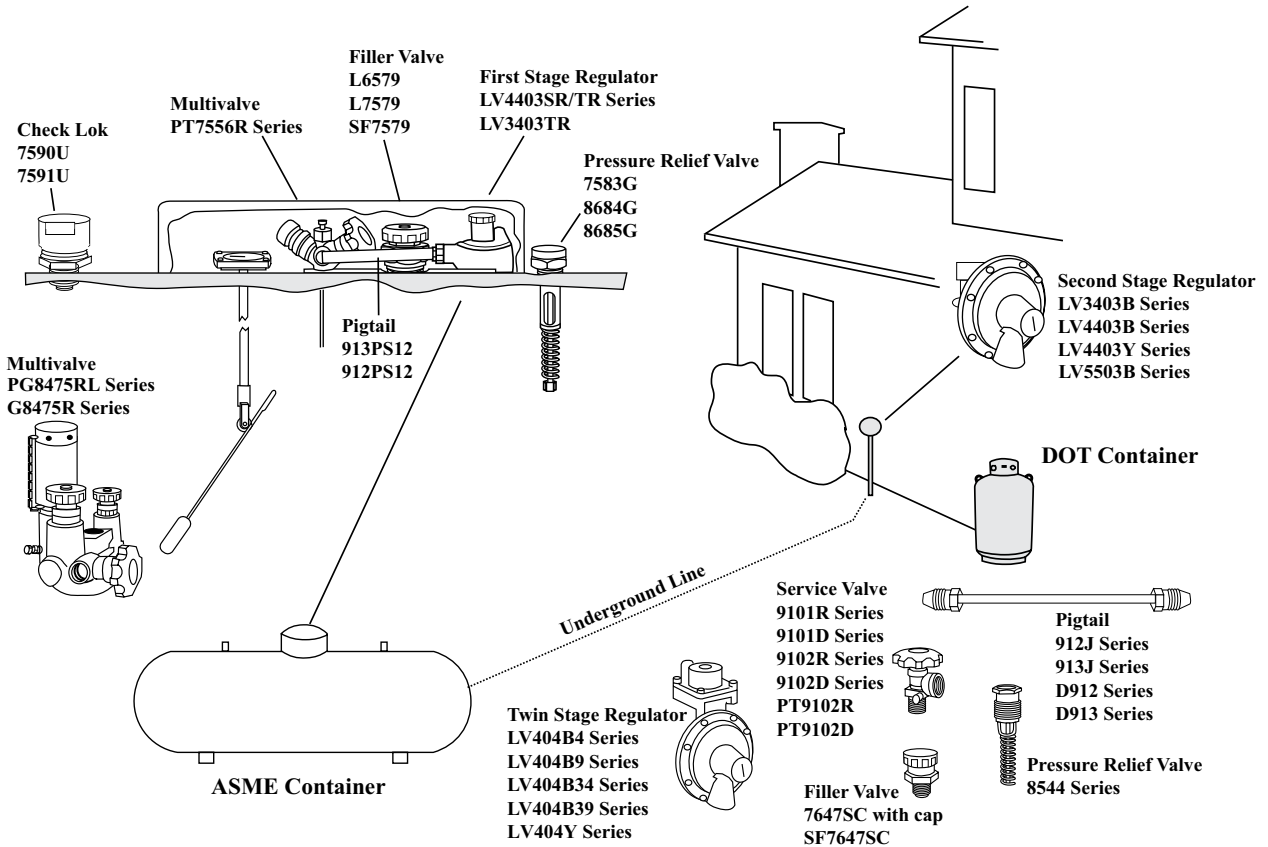

**Disclaimer:** The illustrations in this application guide are intended to inform a professional installer/system designer where our valves are generally installed on certain containers or applications. These illustrations are not intended for and must not be used for system design.

## Emergency Shut Off Valves

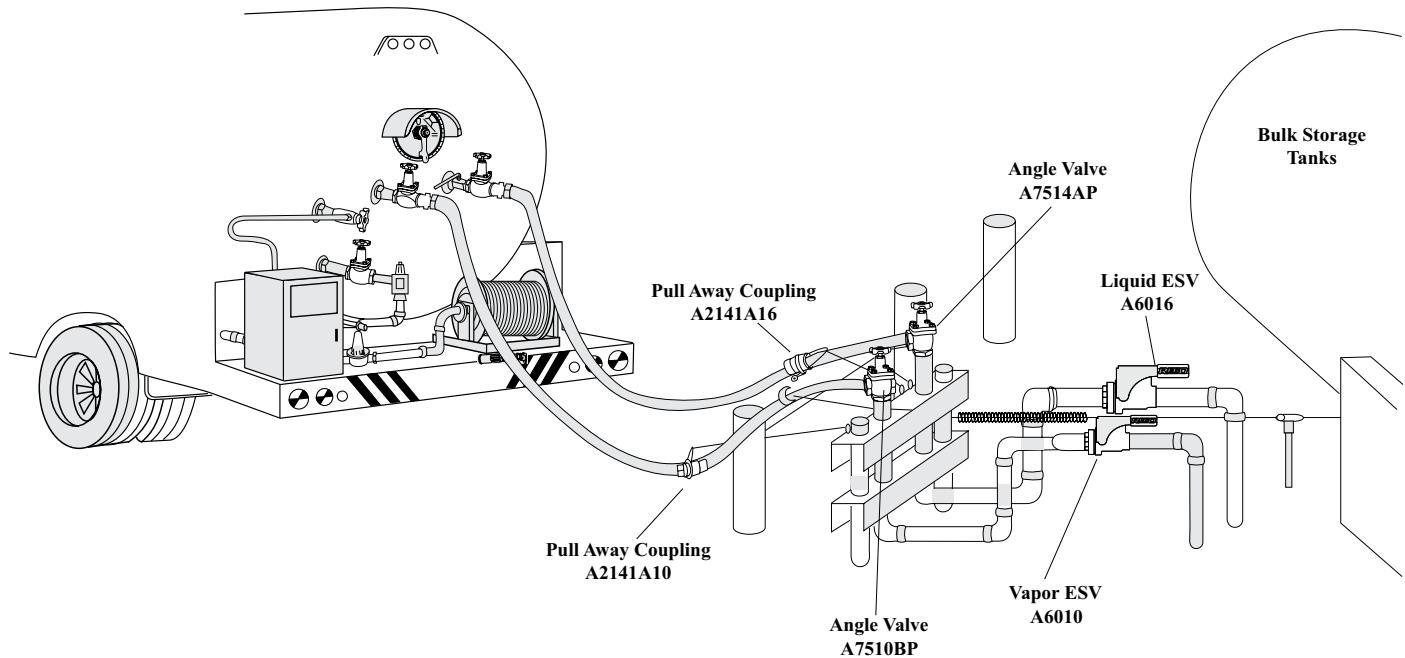

**Disclaimer:** The illustrations in this application guide are intended to inform a professional installer/system designer where our valves are generally installed on certain containers or applications. These illustrations are not intended for and must not be used for system design.

## Motor Fuel Applications

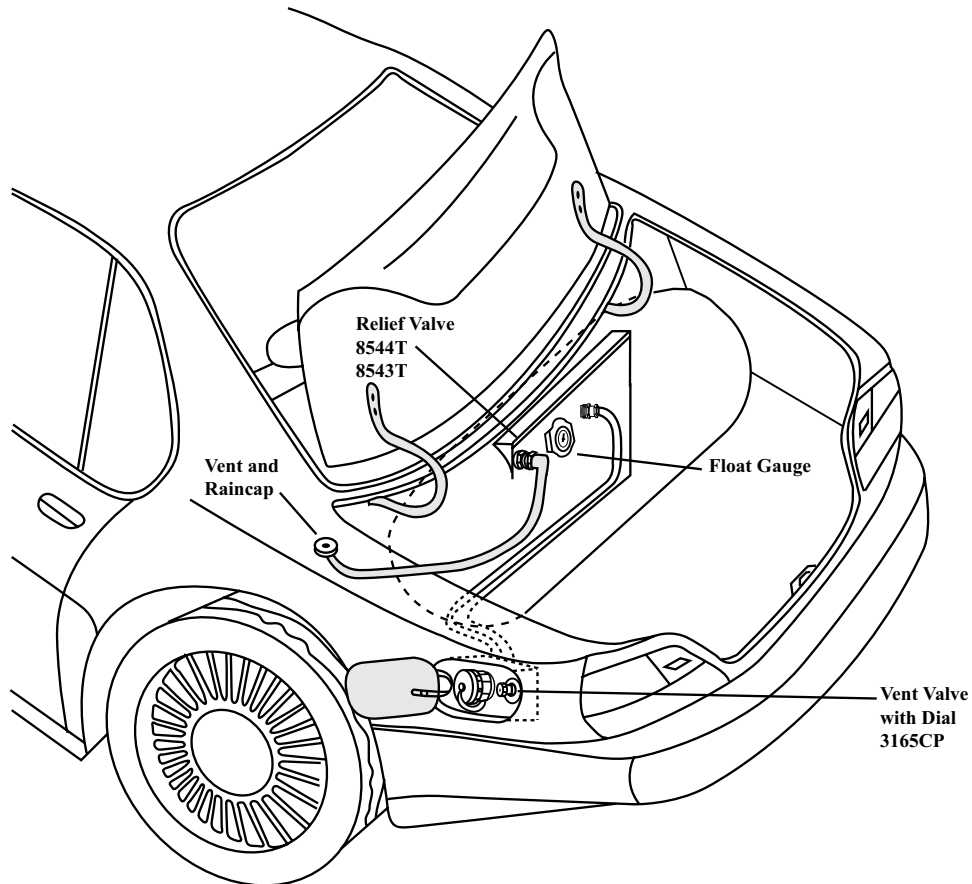

*Disclaimer: The illustrations in this application guide are intended to inform a professional installer/system designer where our valves are generally installed on certain containers or applications. These illustrations are not intended for and must not be used for system design.*

## More Motor Fuel Applications

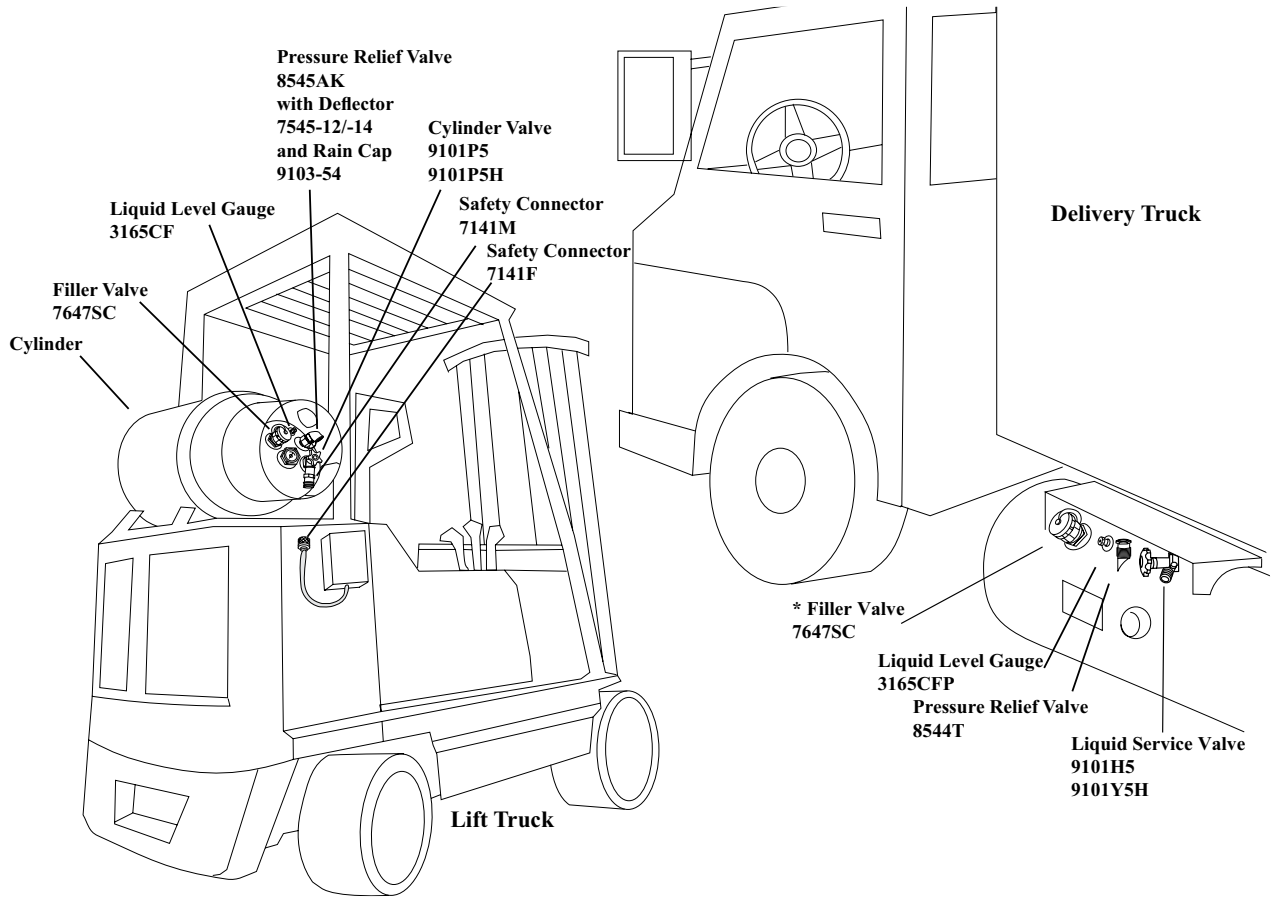

**Disclaimer:** The illustrations in this application guide are intended to inform a professional installer/system designer where our valves are generally installed on certain containers or applications. These illustrations are not intended for and must not be used for system design.

## Recreational Applications

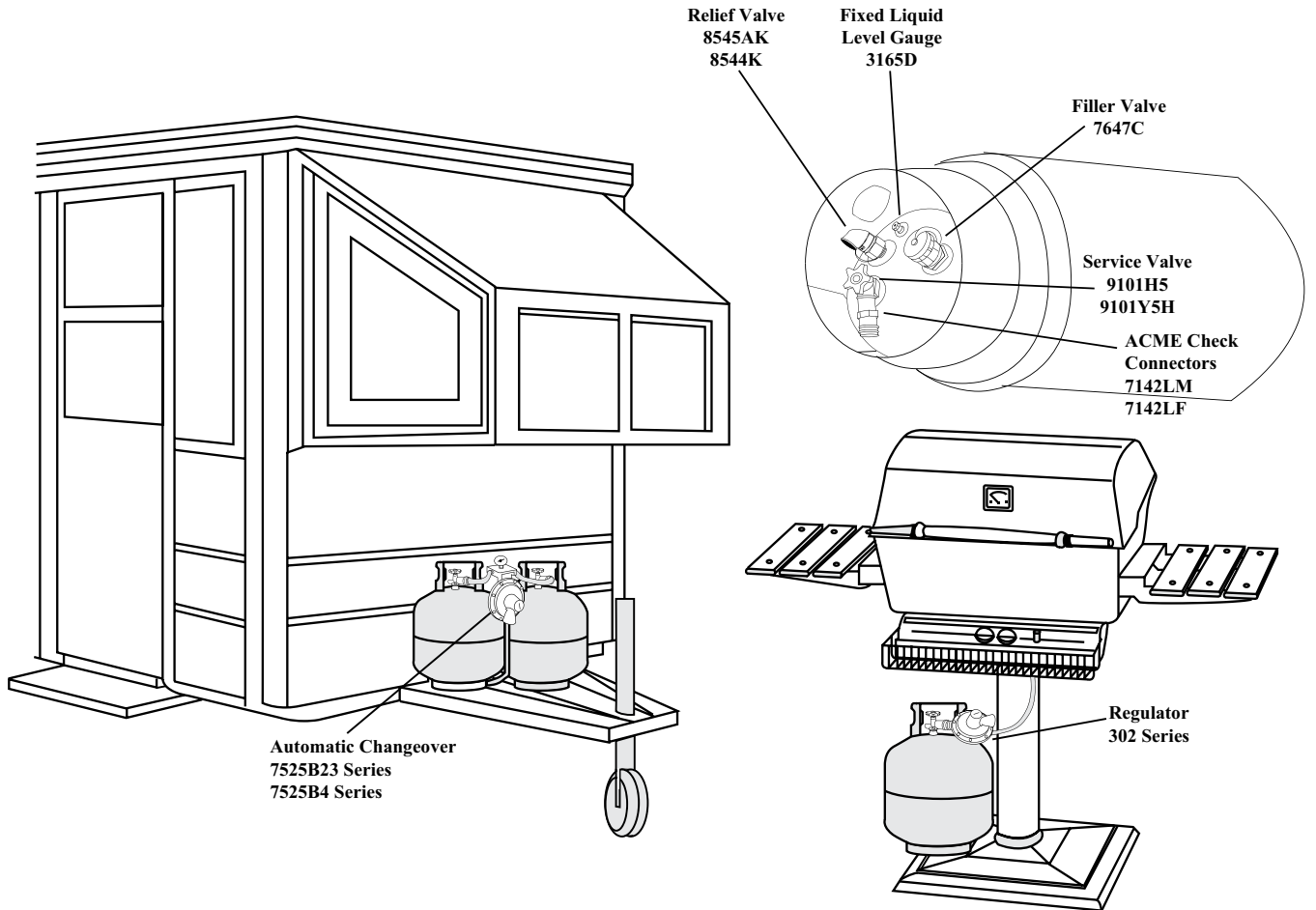

*Disclaimer: The illustrations in this application guide are intended to inform a professional installer/system designer where our valves are generally installed on certain containers or applications. These illustrations are not intended for and must not be used for system design.*





## TWO STAGE REGULATOR

### Quick Reference Guide For **REGO** Regulators

Make sure you are thoroughly trained before you attempt any regulator installation or maintenance. Improper conditions or procedures can cause accidents resulting in property damage and personal injury.

Then Choose Your Pigtails, Nuts, Fittings & Risers

#### BTU Load

#### 400,000 btu/hr.

**DISTANCE:** 80 feet  
**PIPE SIZE:** 1/2" CTS Poly pipe or copper tubing @ 10 psi

If copper piping is chosen see "Copper Piping" for size & part number

#### REGULATORS:

**LV3403TR**  
1/4" X 1/2"  
1ST STAGE



**LV4403B4**  
1/2" X 1/2"  
2ND STAGE  
straight outlet



#### PIGTAILS:



TYPE	SIZE	PART #
1/4" x POL	3/8" tube x 12"	913JS12
1/4" x POL	1/4" tube x 12"	912JS12
POL x POL	3/8" tube x 12"	913PS12
POL x POL	1/4" tube x 12"	912PS12

#### 600,000 btu/hr.

**DISTANCE:** 40 feet  
**PIPE SIZE:** 1/2" CTS Poly pipe or copper tubing @ 10 psi

**DISTANCE:** 100 feet  
**PIPE SIZE:** 3/4" IPS Poly pipe @ 10 psi

If copper piping is chosen see "Copper Piping" for size & part number

#### REGULATORS:

**LV3403TR**  
1/4" X 1/2"  
1ST STAGE



**LV4403B46R**  
1/2" X 3/4"  
2ND STAGE  
back mounting



#### NUTS:



SIZE	PART #
1/2" nut	NS4F
5/8" nut	NS4I

#### 800,000 btu/hr.

**DISTANCE:** 20 feet  
**PIPE SIZE:** 1/2" CTS Poly pipe or copper tubing @ 10 psi

**DISTANCE:** 70 feet  
**PIPE SIZE:** 3/4" IPS Poly pipe @ 10 psi

If copper piping is chosen see "Copper Piping" for size & part number

#### REGULATORS:

**LV3403TR**  
1/4" X 1/2"  
1ST STAGE



**LV4403B66**  
3/4" X 3/4"  
2ND STAGE



#### FITTINGS:



SIZE		PART #
MFL	MPT	
1/2"	1/2"	48FF
5/8"	1/2"	48IF
1/2"	3/4"	48FK
5/8"	3/4"	48IK

#### 1,000,000 btu/hr.

**DISTANCE:** 15 feet  
**PIPE SIZE:** 1/2" CTS Poly pipe or copper tubing @ 10 psi

**DISTANCE:** 40 feet  
**PIPE SIZE:** 5/8" Copper Tubing @ 10 psi

**DISTANCE:** 400 feet  
**PIPE SIZE:** 3/4" IPS Poly pipe @ 10 psi

If copper piping is chosen see "Copper Piping" for size & part number

#### REGULATORS:

**LV3403TR**  
1/4" X 1/2"  
1ST STAGE



**LV5503B6**  
3/4" X 3/4"  
2ND STAGE  
straight outlet



#### RISERS:

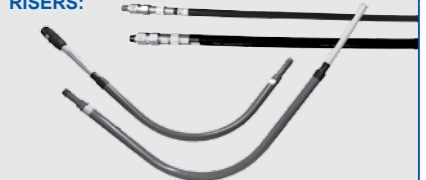

TYPE	SIZE	PART #
Flex	1/2" CTS x 1/2" MPT x 36"	71354
Flex	1/2" CTS x 1/2" MPT x 84"	71353
Flex	3/4" IPS x 3/4" MPT x 36"	71410
Flex	3/4" IPS x 3/4" IPS x 84"	71412
Hard	1/2" CTS x 1/2" MPT	77253
Hard	3/4" IPS x 3/4" MPT	79209
Hard	1" IPS x 1" MPT	78442

#### 2,000,000 btu/hr.

**DISTANCE:** 10 feet  
**PIPE SIZE:** 5/8" Copper Tubing @ 10 psi

**DISTANCE:** 100 feet  
**PIPE SIZE:** 3/4" IPS Poly pipe @ 10 psi

If copper piping is chosen see "Copper Piping" for size & part number

#### REGULATORS:

**LV4403TR9**  
FPOL X 1/2"  
1ST STAGE



**LV5503B8**  
3/4" X 1"  
2ND STAGE  
straight outlet



#### COPPER TUBING:



SIZE	PART #
1/2" OD x 50'	CCR-1/2X50
1/2" OD x 100'	CCR-1/2X100
5/8" OD x 50'	CCR-5/8X50
5/8" OD x 100'	CCR-5/8X100

#### Presto-Tap Universal Service Tech Kit

##### USES:

- Leak testing at tank pressure with Presto Tap pigtails.
- Determining 1st or 2nd stage regulator lock up
- Determining lock up and flow on Two Pound systems
- Low pressure leak testing
- Plug removal in regulators

##### PARTS INCLUDED:

- 6800-KG
- PT-30KG
- PT-5KG
- PT-OZ
- MHA-STRAIGHT
- 316 ALLEN KEY
- UNIVERSAL FLEX HOSE
- RV
- KIT BAG

#### UNIVERSAL-SERVICE-TECH-KIT

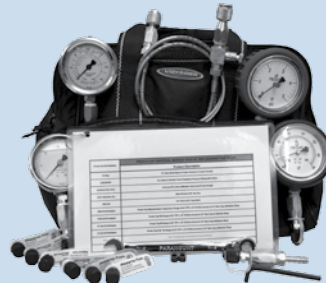

See RegO's LP-GAS Serviceman's Manual L-545 for Examples & Reference Tables



## TWIN STAGE REGULATOR

### Quick Reference Guide For **REGO** Regulators

Make sure you are thoroughly trained before you attempt any regulator installation or maintenance. Improper conditions or procedures can cause accidents resulting in property damage and personal injury.

#### BTU Load

#### 100,000 btu/hr.

**DISTANCE: 10 feet**  
**PIPE SIZE: 1/2" CTS**

Poly pipe or copper tubing @ 11" water column regulator set pressure

**DISTANCE: 35 feet**  
**PIPE SIZE: 5/8"**

copper tubing @ 11" water column regulator set pressure

**DISTANCE: 100 feet**  
**PIPE SIZE: 3/4" IPS**

Poly pipe @ 11" water column regulator set pressure

#### REGULATOR:

LV404B34  
1/4" X 1/2"



If copper piping is chosen see "Copper Piping" for size & part number

#### 200,000 btu/hr.

**DISTANCE: 10 feet**  
**PIPE SIZE: 5/8" copper tubing**  
@ 11" water column regulator set pressure

**DISTANCE: 50 feet**  
**PIPE SIZE: 3/4" IPS Poly pipe**  
@ 11" water column regulator set pressure

#### REGULATOR:

LV404B34  
1/4" X 1/2"



If copper piping is chosen see "Copper Piping" for size & part number

#### 300,000 btu/hr.

**DISTANCE: 30 feet**  
**PIPE SIZE: 3/4" IPS Poly pipe**  
@ 11" water column regulator set pressure

**DISTANCE: 70 feet**  
**PIPE SIZE: 1" IPS Poly pipe**  
@ 11" water column regulator set pressure

#### REGULATORS:

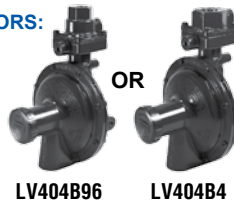

LV404B96

LV404B4

If copper piping is chosen see "Copper Piping" for size & part number

#### 400,000 btu/hr.

**DISTANCE: 20 feet**  
**PIPE SIZE: 3/4" IPS Poly pipe**  
@ 11" water column regulator set pressure

**DISTANCE: 20 feet**  
**PIPE SIZE: 1" IPS Poly pipe**  
@ 11" water column regulator set pressure

#### REGULATORS:

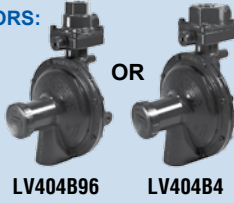

LV404B96

LV404B4

If copper piping is chosen see "Copper Piping" for size & part number

#### Piping & Tubing Sizing Instructions

This method will assure the selection of the correct sizes of piping and tubing for LP Gas vapor systems. Piping between first and second stage regulators is considered, as well as low pressure (inches water column) piping between second stage, single stage, or integral twin stage regulators and appliances.

#### INSTRUCTIONS:

- Determine the total gas demand for the system by adding up the BTU/hr input from the appliance nameplates and adding demand as appropriate for future appliances.
- Second stage or integral twin stage piping:
  - Measure length of piping required from outlet of regulator to the appliance furthest away. No other length is necessary to do the sizing.
  - Make a simple sketch of the piping, as shown.
  - Determine the capacity to be handled by each section of piping. For example, the capacity of the line between A & B must handle the total demand of appliances A, B, & C; the capacity of the line from c to d must handle only appliance B, etc.

D. Select proper size of tubing or pipe for each section of piping, using values in BTU/hr for the length determined from step #2-A. If exact length is not on chart, use next longer length. Do not use any other length for this purpose! Simply select the size that shows at least as much capacity as needed for each piping section.

#### 3. For piping between first and second stage regulators

- For a system with only one second stage regulator, measure length of piping required between outlet of first stage and inlet of second stage regulators. Select piping or tubing required.
- For systems with multiple second stage regulators, measure length of piping required to reach the second stage regulator that is furthest away. Make a simple sketch, and size each leg of piping using the table using values shown in column corresponding to the length as measured above, same as when handling second stage piping.

See Piping & Tubing Selection Guide Poster For Examples and Reference Tables or Rego's LP-GAS Serviceman's Manual L-545

#### Then Choose Your Pigtails, Nuts, Fittings & Risers

#### PIGTAILS:

TYPE	SIZE	PART #
1/4" x POL	3/8" tube x 12"	913JS12
1/4" x POL	1/4" tube x 12"	912JS12
1/4" x POL	3/8" tube x 5"	913JS05
1/4" x POL	1/4" tube x 5"	912JS05
POL x POL	3/8" tube x 12"	913PS12
POL x POL	1/4" tube x 12"	912PS12



#### NUTS:



SIZE	PART #
1/2" nut	NS4F
5/8" nut	NS4I

#### FITTINGS:



	SIZE		PART #
	MFL	MPT	
1/2"	1/2"	48FF	
5/8"	1/2"	48IF	

#### RISERS:

TYPE	SIZE	PART #
Flex	1/2" CTS x 1/2" CTS x 36"	71354
Flex	1/2" CTS x 1/2" CTS x 84"	71353
Flex	3/4" IPS x 3/4" IPS x 36"	71410
Flex	3/4" IPS x 3/4" IPS x 84"	71412
Hard	1" IPS x 1" MPT	78442

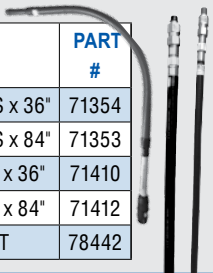

#### COPPER TUBING:



SIZE	PART #
1/2" OD x 50'	CCR-1/2 X 50
1/2" OD x 100'	CCR-1/2 X 100
5/8" OD x 50'	CCR-5/8 X 50
5/8" OD x 100'	CCR-5/8 X 100

TABLE 3

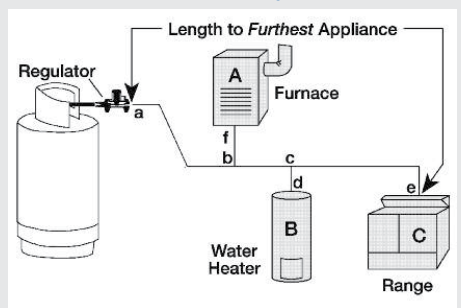

See Rego's LP-GAS Serviceman's Manual L-545 for Examples & Reference Tables





## RESIDENTIAL/COMMERCIAL Quick Reference Guide For Perfection

### Permasert® Polyethylene Mechanical Fittings and Risers

Make sure you are thoroughly trained before you attempt any regulator installations. Improper conditions or procedures can cause accidents resulting in property damage and personal injury.

Polyethylene piping systems shall be limited to: 1) Vapor service not exceeding 30 psig 2) Installation outdoors and underground with a minimum of 18" of cover, except the cover may be reduced to 12", if external damage to the pipe is not likely to result. Check your local codes.

#### Mechanical Couplings

PART #	SIZE	SDR/ WALL
50100	1/2" CTS	.090
50030	3/4" IPS	SDR 11
50601	1" IPS	
50035010	1-1/4" IPS	SDR 10
50314	2" IPS	SDR 11



#### Coppersert™ Copper to PE Fittings

SIZE	PART #
1/2" CTS x 3/8" Flare	41007
1/2" CTS x 1/2" Flare	41013
1/2" CTS x 5/8" Flare	41002
3/4" IPS x 5/8" Flare	41130
1" CTS x 5/8" Flare	41150



#### Permasert Three-Way Tees

PART #	SIZE	SDR/ WALL
50199	1/2" CTS	.090
50929	3/4" IPS	SDR 11
50634	1" IPS	
50327010	1-1/4" IPS	SDR 10
50316	2" IPS	SDR 11



#### Anodeless Service Line Risers

##### Permasert Mechanical Ends

PART #	OUTLET	INLET	SDR/ WALL	VERTI- CAL	HORIZON- TAL
77253	1/2" MPT	1/2" CTS	.090	30"	24"
75192	3/4" MPT	1/2" CTS	.090	30"	24"
77201	3/4" MPT	1/2" CTS	.090	22"	18"
79209	3/4" MPT	3/4" IPS	SDR 11	30"	24"
78442	1" MPT	1" IPS	—	30"	24"
75901	1-1/4" MPT	1-1/4" IPS	—	30"	24"
75906	2" IPS	2" IPS	SDR 11	30"	15"

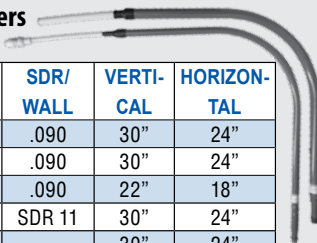

#### Polyethylene Piping

PART #	SIZE	COIL LENGTH	I.D.	NOM- INAL O.D.	SDR	MINIMUM WALL THICK- NESS
PP-1/2CTS	Medium density polyethylene piping	500 ft.	1/2"	0.625"	7	.090"
PP-3/4IPS			3/4"	1.050"	11	.095"
PP-1IPS			1"	1.315"		.120"
PP-1 1/4IPS			1-1/4"	1.660"		10
PP-2IPS			2"	250 ft.	2"	2.375"



#### Anodeless Servi-Sert® Field- Assembled All-flex Risers\* (with Swivel Connector/Union)

PART #	OUTLET	INLET	OVERALL LENGTH
71353	1/2" MNPT	1/2 CTS Poly Pipe	84"
71354			36"
71355			84"
71356			36"
71412	3/4" MNPT	3/4" IPS	84"
71410			36"
71411			60"



#### Permasert Blind End Caps

Caps: stop & go –  
both ends functional

PART #	SIZE	SDR/ WALL
50016	1/2" CTS	.090
50026	3/4" IPS	SDR 11
50033	1-1/4" IPS	SDR 10
50317	2" IPS	SDR 11

#### Permasert Three-Way Reducing Tees

PART #	SIZE	SDR/ WALL	SIZE	SDR/ WALL	SIZE	SDR/ WALL
50461	3/4" IPS	SDR 11	3/4" IPS	SDR 11	1/2" CTS	.090"
50635	1" IPS		1" IPS		3/4" IPS	
50328100	1-1/4" IPS	SDR 10	1-1/4" IPS	SDR 10	1" CTS	SDR 11
51283	2" IPS	SDR 11	2" IPS	SDR 11	1" IPS	SDR 11
51323100			2" IPS		1-1/4" IPS	



#### Servi-Sert® Replacement Service Head Adaptors

PART #	OUTLET	INLET	Service head adaptors ONLY
71110	1/2" MNPT	1/2" CTS	Service head adaptors ONLY
71100	3/4" MNPT	1-1/4 IPS	
71161		3/4" IPS	

Approved by NFPA-58, 1998 Edition (Check  
Local Jurisdictions.)

#### Tools and Accessories

PART #	DESCRIP- TION	SIZE
51016	Chamfering tool	1/2" CTS x 3/4" IPS
51008		3/4" IPS x 1" IPS
51028		1-1/4 IPS
51040		2" IPS
55290	Plastic cutter	Snips 1/8"–1 1/2" OD
55291		Snips 1/8"–2 3/8" OD



NOTE: The above part numbers represent our most  
popular components. For other sizes or custom config-  
urations, please inquire.

#### Repair Couplings

PART #	SIZE	SDR/ WALL	LENGTH
50056	1/2" CTS	.090	12"
50175	3/4" IPS	SDR 11	
50640	1" IPS	SDR 11	
50320100	1-1/4" IPS	SDR 10	
50341	2" IPS	SDR 11	15"

NOTE: Polyethylene pipe/tubing shall be limited to va-  
por service, not exceeding 30 psig, and must be installed  
outdoors and underground.

#### Transition Fittings

PART #	DESCRIP- TION	SIZE	APPROXIMATE DIMEN- SION
700004	Transition, threaded	1/2" MNPT x 1/2" CTS	16-1/2"
700205		3/4" MNPT x 1/2" CTS	16"
700802		3/4" MNPT x 3/4" IPS	17"
707202		1" MNPT x 1" IPS	17"
702205		1-1/4" MNPT x 1-1/4" IPS	16-1/2"
702602		2" MNPT x 2" IPS	18-1/2"



#### Locator Tape and Wire

Tracer Tape should be placed in trench a  
minimum of 6" above polyethylene pipe.  
The metallic tape allows for easy loca-  
tion of plastic pipe with metal detector.

PART #	DESCRIPTION	COIL LENGTH
715-NCGT21	Metallic locator tape	2" x 1,000 ft. roll
NO.12	PE coated copper #12"	500 ft. roll



#### Permasert Elbows

PART #	SIZE	SDR/ WALL
50294	1/2" CTS	.090
51620	3/4" IPS	SDR 11
50636	1" IPS	
50325010	1-1/4" IPS	SDR 10
50315	2" IPS	SDR 11





## 2PSIG REGULATORS

### Quick Reference Guide For 2 Stage or 3 Stage Systems

See Twin Regulators for Low Pressure Systems

2 Stage 10 PSIG System		3 Stage 2 PSIG System	
<b>1st Stage</b> <b>LV3403TR</b> 1,500,000 btu/hr. 1/4" F.NPT X 1/2" F.NPT		<b>1st Stage</b> <b>LV3403TR</b> 1,500,000 btu/hr. 1/4" F.NPT X 1/2" F.NPT	<b>1st Stage</b> <b>LV4403TR9</b> 2,500,000 btu/hr. F.POL X 1/2" F.NPT
<b>1st Stage</b> <b>LV4403TR9</b> 2,500,000 btu/hr. F.POL X 1/2" F.NPT		<b>2nd Stage</b> <b>LV4403Y46R</b> 1,000,000 btu/hr. 1/2" F.NPT X 3/4" F.NPT	<b>2nd Stage</b> <b>LV5503Y6</b> 2,200,000 btu/hr. 3/4" F.NPT X 3/4" F.NPT
<b>2nd Stage</b> <b>LV3403B46R</b> 450,000 btu/hr. 1/2" F.NPT X 3/4" F.NPT		<b>3rd Stage</b> <b>325-3L</b> 250,000 btu/hr. 1/2" F.NPT X 1/2" F.NPT	
<b>2nd Stage</b> <b>LV4403B66</b> 950,000 btu/hr. 3/4" F.NPT X 3/4" F.NPT		<b>325-5L</b> 600,000 btu/hr. 1/2" F.NPT X 1/2" F.NPT	<b>325-7AL</b> 1,250,000 btu/hr. 1-1/4" F.NPT X 1-1/4" F.NPT

See the Twin Regulator for Low Pressure Systems

#### 2 PSIG Line Sizing Chart – Pipe & Copper

2 PSIG inlet with a .2 PSIG Pressure Drop

Maximum capacity of pipe or tubing in 1000's of BTU/hr of LP-Gas

SIZE OF PIPE OR COPPER TUBING, INCHES	LENGTH OF PIPE OR TUBING, FEET																				
	10	20	30	40	50	60	70	80	90	100	125	150	175	200	225	250	275	300	350	400	
COPPER TUBING (O.D.)	3/8"	176	121	97	83	74	67	61	57	54	51	45	41	37	35	33	31	29	28	26	24
	1/2"	363	249	200	171	152	138	127	118	111	104	93	84	77	72	67	64	60	58	53	49
	5/8"	738	507	407	349	309	280	258	240	225	212	188	171	157	146	137	129	123	117	108	100
PIPE SIZE	3/4"	1290	887	712	609	540	489	450	419	393	271	329	298	274	255	239	226	215	205	188	175
	1/2"	1140	784	629	539	477	432	398	370	347	328	291	263	242	225	212	200	190	181	167	155
	3/4"	2384	1638	1316	1126	998	904	832	774	726	686	608	551	507	471	442	418	397	379	348	324
	1"	4491	3086	2479	2120	1880	1703	1567	1458	1368	1292	1145	1038	955	888	833	787	748	713	656	610
	1-1/4"	9215	6333	5087	4352	3858	3495	3215	2991	2806	2652	2350	2129	1963	1824	1710	1616	1539	1464	1345	1252
	1-1/2"	13809	9491	7623	6521	5781	5235	4816	4480	4203	3973	3523	3191	2939	2731	2560	2420	2306	2194	2017	1878
	2"	26597	18280	14683	12560	11135	10084	9277	8630	8096	7652	6848	6252	5659	5259	4931	4661	4438	4223	3883	3615
	2-1/2"	42391	29135	23402	20019	17747	16075	14788	13756	12904	12197	10814	9795	9021	8384	7860	7429	7074	6731	6187	5761
	3"	74938	51504	41369	35389	31373	29784	27400	25488	23872	22563	19177	17316	15946	14820	13897	13135	12508	11901	10940	10186

Data Calculated per NFPA #54 & 58



## TWIN STAGE REGULATOR

### Quick Reference Guide For **REGO** Regulators

Make sure you are thoroughly trained before you attempt any regulator installation or maintenance. Improper conditions or procedures can cause accidents resulting in property damage and personal injury.

#### BTU Load

#### 100,000 btu/hr.

**DISTANCE: 10 feet**  
**PIPE SIZE: 1/2" CTS**  
Poly pipe or copper tubing @ 11" water column regulator set pressure

**DISTANCE: 35 feet**  
**PIPE SIZE: 5/8"**  
copper tubing @ 11" water column regulator set pressure

**DISTANCE: 100 feet**  
**PIPE SIZE: 3/4" IPS**  
Poly pipe @ 11" water column regulator set pressure

#### REGULATOR:

**LV404B39**  
FPOL x 1/2 MPT



If copper piping is chosen see "Copper Piping" for size & part number

#### 200,000 btu/hr.

**DISTANCE: 10 feet**  
**PIPE SIZE: 5/8" copper tubing**  
@ 11" water column regulator set pressure

**DISTANCE: 50 feet**  
**PIPE SIZE: 3/4" IPS Poly pipe**  
@ 11" water column regulator set pressure

#### REGULATOR:

**LV404B39**  
FPOL x 1/2 MPT



If copper piping is chosen see "Copper Piping" for size & part number

#### 300,000 btu/hr.

**DISTANCE: 30 feet**  
**PIPE SIZE: 3/4" IPS Poly pipe**  
@ 11" water column regulator set pressure

**DISTANCE: 70 feet**  
**PIPE SIZE: 1" IPS Poly pipe**  
@ 11" water column regulator set pressure

#### REGULATOR:

**LV404B96**  
FPOL x 3/4 MPT



If copper piping is chosen see "Copper Piping" for size & part number

#### 400,000 btu/hr.

**DISTANCE: 20 feet**  
**PIPE SIZE: 3/4" IPS Poly pipe**  
@ 11" water column regulator set pressure

**DISTANCE: 20 feet**  
**PIPE SIZE: 1" IPS Poly pipe**  
@ 11" water column regulator set pressure

#### REGULATOR:

**LV404B96**  
FPOL x 3/4 MPT



If copper piping is chosen see "Copper Piping" for size & part number

#### Piping & Tubing Sizing Instructions

This method will assure the selection of the correct sizes of piping and tubing for LP Gas vapor systems. Piping between first and second stage regulators is considered, as well as low pressure (inches water column) piping between second stage, single stage, or integral twin stage regulators and appliances.

#### INSTRUCTIONS:

- Determine the total gas demand for the system by adding up the BTU/hr input from the appliance nameplates and adding demand as appropriate for future appliances.
- Second stage or integral twin stage piping:
  - Measure length of piping required from outlet of regulator to the appliance furthest away. No other length is necessary to do the sizing.
  - Make a simple sketch of the piping, as shown.
  - Determine the capacity to be handled by each section of piping. For example, the capacity of the line between A & B must handle the total demand of appliances A, B, & C; the capacity of the line from c to d must handle only appliance B, etc.
  - Select proper size of tubing or pipe for each

section of piping, using values in BTU/hr for the length determined from step #2-A. If exact length is not on chart, use next longer length. Do not use any other length for this purpose! Simply select the size that shows at least as much capacity as needed for each piping section.

3. For piping between first and second stage regulators

A. For a system with only one second stage regulator, measure length of piping required between outlet of first stage and inlet of second stage regulators. Select piping or tubing required.

B. For systems with multiple second stage regulators, measure length of piping required to reach the second stage regulator that is furthest away. Make a simple sketch, and size each leg of piping using the table using values shown in column corresponding to the length as measured above, same as when handling second stage piping.

See Piping & Tubing Selection Guide Poster For Examples and Reference Tables or Rego's LP-GAS Serviceman's Manual L-545

#### Then Choose Your Pigtails, Nuts, Fittings & Risers

#### PIGTAILS:

TYPE	SIZE	PART #
M.POL x M.POL	1/4" tube x 12"	912PS12
M.POL x M.POL	3/8" tube x 12"	913PS12
M.POL x M.POL	1/4" tube x 20"	912PS20
M.POL x M.POL	3/8" tube x 20"	913PS20
M.POL x M.POL	1/4" tube x 30"	912PS30
M.POL x M.POL	3/8" tube x 30"	913PS30

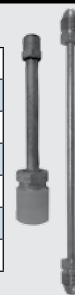

#### NUTS:



SIZE	PART #
1/2" nut	NS4F
5/8" nut	NS4I

#### FITTINGS:



SIZE	PART #	
		MFL
1/2"	1/2"	48FF
5/8"	1/2"	48IF

#### RISERS:

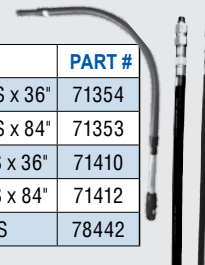

TYPE	SIZE	PART #
Flex	1/2" MPT x 1/2" CTS x 36"	71354
Flex	1/2" MPT x 1/2" CTS x 84"	71353
Flex	3/4" MPT x 3/4" IPS x 36"	71410
Flex	3/4" MPT x 3/4" IPS x 84"	71412
Hard	1" MPT x 1" IPS	78442

#### COPPER TUBING:



SIZE	PART #
1/2" OD x 50'	CCR-1/2 X 50
1/2" OD x 100'	CCR-1/2 X 100
5/8" OD x 50'	CCR-5/8 X 50
5/8" OD x 100'	CCR-5/8 X 100

TABLE 3

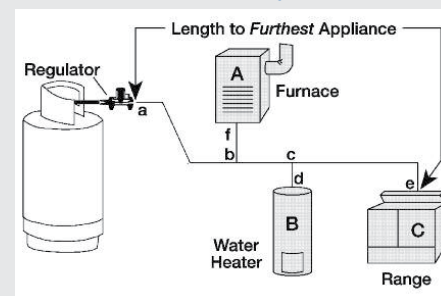

See Rego's LP-GAS Serviceman's Manual L-545 for Examples & Reference Tables



## ASME TANK REFURBISH

### Quick Reference Guide For **REGO** Valves

Make sure you are thoroughly trained before you attempt any ASME tank maintenance. Improper conditions or procedures can cause accidents resulting in property damage and personal injury.

Tank configuration shown is appropriate for tanks built since the mid-1970's. If yours does not match, please call the Tarantin Industries location nearest you and we will be glad to help.

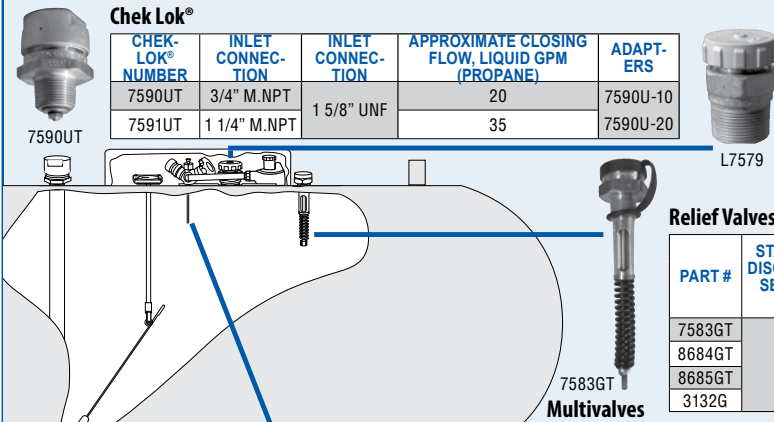

#### Chek Lok®

CHEK-LOK® NUMBER	INLET CONNECTION	INLET CONNECTION	APPROXIMATE CLOSING FLOW, LIQUID GPM (PROPANE)	ADAPT-ERS
7590UT	3/4" M.NPT	1 5/8" UNF	20	7590U-10
7591UT	1 1/4" M.NPT		35	7590U-20

#### Filler Valve

PART #	ACME HOSE CONNECTION	TANK CONNECTION M.NPT
7647SCT	1 3/4"	3/4"
L7579	1 3/4"	1 1/4"
3174-9P	Cap	
3174-93L	Cap w/Lanyard	

#### Filler Valve Repair Kits:

For L7579: L7579-80 Contains: Gaskets, seat disc and retainer assembly & spring. For L7647: L7647-80 Filler Valve Washers Pkg. of 25 A2697-20R

#### Relief Valves

PART #	START TO DISCHARGE SETTING PSIG	CONTAINER CONNECTION M.NPT	FLOW CAPACITY SCFM/AIR		SUITABLE FOR TANKS W/SURFACE AREA UP TO:	RAIN CAPS
			UL (AT 120% OF SET PRES-SURE)	ASME (AT 120% OF SET PRES-SURE)		
7583GT	250	3/4"	1980	1806	80 Sq. Ft.	7583-40X
8684GT			2620	2565	113 Sq. Ft.	8684-40
8685GT			4385	4035	212 Sq. Ft.	7583-40X
3132G		1 1/4"	4130		200 Sq. Ft.	3132-54

#### Multivalves

PART #	CONTAINER CONNECTION	SERVICE CONNECTION	FILLING CONNECTION	VAPOR EQUALIZING CONNECTION	FLOAT GAUGE FLANGE OPENING	FIXED LIQUID LEVEL VENT VALVE STYLE	PRESSURE RELIEF VALVE SETTING	FOR USE IN CONTAINERS W/SURFACE AREA UP TO:
G8475RL	2 1/2" F.NPT	F. POL (CGA 510)	1 3/4" M. ACME	1 1/4" M. ACME	Fits "JUNIOR" Size	Knurled	250 PSIG	83 sq. Ft. Above Ground
G8475RLW								276 sq. Ft. Underground
PG8475RL								192 sq. Ft. Above Ground
7556R12.0	3/4" M.NPT		N/A		N/A		N/A	N/A
8593AL16.0	1 1/2" M.NPT		1 3/4" M. ACME		N/A		N/A	N/A

#### Service Valve Repair Kits:

For G8475RL: 19104-50 Contains: MultiBonnet assembly, handwheel, nameplate, and self-tapping screw.

Prior to 1962: 8100-50 Contains: Bonnet assembly.

For 1370, 1480 Series, 2593/K, 2594/K Series: 3100-81K Contains: Bonnet and stem assembly

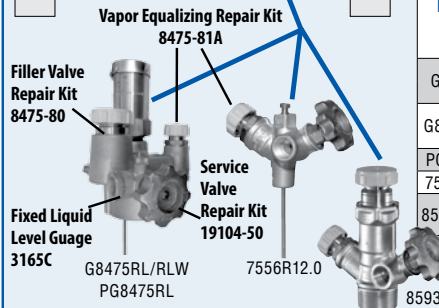

## Domestic Tank Gauges

#### HOW TO ORDER A GAUGE:

1. Determine Tank Type:  Above Ground  Under Ground

2. Determine Gauge Head Type:

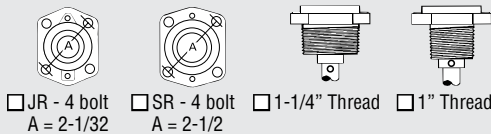

JR - 4 bolt A = 2-1/32  SR - 4 bolt A = 2-1/2

3. Determine Tank Diameter: D = \_\_\_\_\_"

From Tank Data Plate or Measure Circumference (in inches) and divide by 3.14

4. Determine Riser Height: H = \_\_\_\_\_"

Note: Riser height is the distance, in inches, from tank surface to top of mounting flange or coupling for gauge.

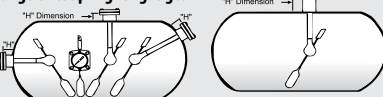

5. Determine Mounting Position:

Top Mount  Angle Mount  Side Mount  End Mount

Note: Pivot point of float must be at center line of tank.

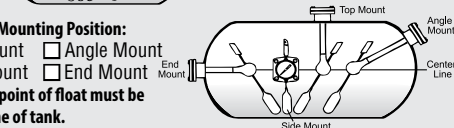

#### OR BUILD YOUR OWN WITH THE NEW R3G ADJUSTABLE LIQUID LEVEL GAUGE

in Junior & Senior Sizes:

1. Select the Gauge Support Assembly

2. Select a Float:

Common Junior & Senior Float Assemblies - Top Mount

STEP 1: \*\* NOTE: These assembly instructions are good for Model #'s 6285-, 6287-, 7287-, & 8987-

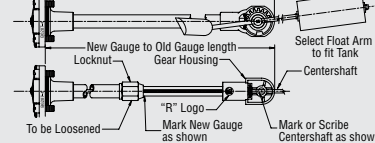

STEP 2: Temporarily adjust Support shorter than the Mark on Centershaft

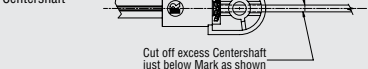

STEP 3:

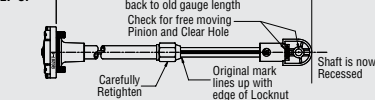

3. Assembly Instructions: Located to the right of the gauge

#### OR the KIT Option:

Part #6287-00001K

Includes: 1 Support Assembly (Jr. 4-Bolt) and 4 Float Assemblies to fit one 24", 30" 32", or 37.5" above ground tank.

STEP 4: Before attaching Float Assembly turn Support Assembly Logo side down. Insert Brass Bearing, 0109-00495, into Gear Housing Turn Support Assembly Logo side up again.

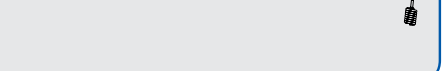
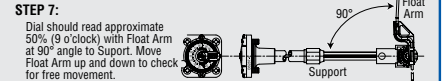
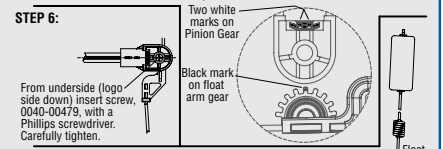
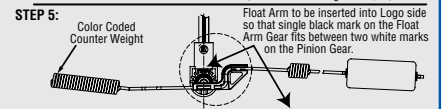

## Tarantin FORKLIFT CYLINDER MAINTENANCE

INDUSTRIES, INC.

### Quick Reference Guide For **REGO** Valves

Make sure you are thoroughly trained before you attempt any cylinder maintenance. Improper conditions or procedures can cause accidents resulting in property damage and personal injury.

#### Filler Valve

PART #	HOSE CONNECTION	TANK CONNECTION M.NPT
7647SCT	1 3/4" ACME	3/4"
3174-9P	Cap Only	
3174-93L	Cap w/Lanyard	

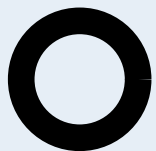

A2697-20R Gasket (25)

#### Filler Valve Repair Kits:

Part #7647B-80A Contains: Seat disc and retainer assembly, spring, gaskets, loctite cement.



7647SCT

#### Vent Valve

PART #	HOSE CONNECTION	TANK CONNECTION M.NPT
3165C	LP-Gas Only	1/4" M. NPT.
3165CP	w/ Warning Plate	1/4" M. NPT



3165CP

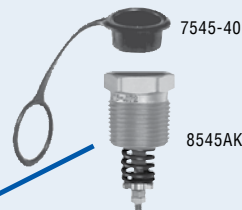

7545-40

8545AKT

#### Pressure Relief Valve

PART #	START TO DIS-CHARGE SETTING PSIG	CONTAINER CONNECTION M.NPT
8545AKT	375	3/4"
7545-40	Rain Cap	
7545-12	90° Elbow Adaptor	
7545-14	45° Elbow Adaptor	



9101P5HT

#### Cylinder Valve

**IMPROVED DESIGN** Reduces handwheel damage due to stacking cylinders.  
 • Lower valve height.  
 • Smaller diameter handwheel.

PART #	CONTAINER CONNECTION	SERVICE CONNECTION	CLOSING FLOW (LP-GAS LIQUID (GPM))
9101P5HT	3/4" M. NGT	3/8" M. NPT	2.6
9101P5	3/4" M. NGT	3/8" M. NPT	1.5

#### Cylinder Valve Repair Kit:

Part #19101-50 Contains: Bonnet, stem and O-ring assembly, handwheel (Part #9101-31), self-tapping screw

#### Safety Connector

PART #	APPLICATION	INLET	OUTLET
7141M	Service Valve	3/8" F. NPT	1 1/4" M. ACME
7141F	Fuel Line	1 1/4" F. ACME	1/4" F. NPT

#### Safety Connector Repair Kit:

Part #7141M-50 Contains: Check assembly, gasket, O-ring, retaining ring.



7141M



7141M-3R Gasket (25)



7513-25 O-ring



7141F



3125L

#### External Hydrostatic Relief Valve

PART #	START TO DIS-CHARGE SETTING PSIG	VALVE BODY MATERIAL	CONTAINER CONNECTION M.NPT	HEIGHT (APPROX.)	WRENCH HEX SECTION
3125L	400	Brass	1/4"	1 9/16"	5/8"
3125-40P	Protective Cap				

## Forklift Cylinder Gauges



5-01791

#### Replacement Dials for Rochester Float Gauges

PART #	DIAL SIZE	TYPE OF TANK
5-01791	Junior	33LB Universal



2733U-CV



2743U-CV

#### Taylor Visible Replacement Dials

PART #	DESCRIPTION
2733U-CV	JR Universal 33LB Motor Fuel
2743U-CV	JR Universal 43LB Motor Fuel

#### Float Gauges for Forklift Cylinders

CYLINDER SIZE	PART NUMBER	
	JR. GAUGE	1 1/4" MPT
33 1/2 LB	JU160B	TU160B
43 1/2 LB	JU212A	TU212A

JU160B

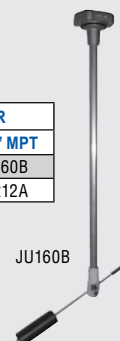







## VAPORIZER INSTALLATION (front side)

### Quick Reference Guide For Vaporizers

Make sure you are thoroughly trained before you attempt any vaporizer installations. Improper conditions or procedures can cause accidents resulting in property damage and personal injury.

**ALWAYS FOLLOW ORIGINAL EQUIPMENT MANUFACTURER'S GUIDELINES.**

Typical Installation - Principal Features and Operating Characteristics

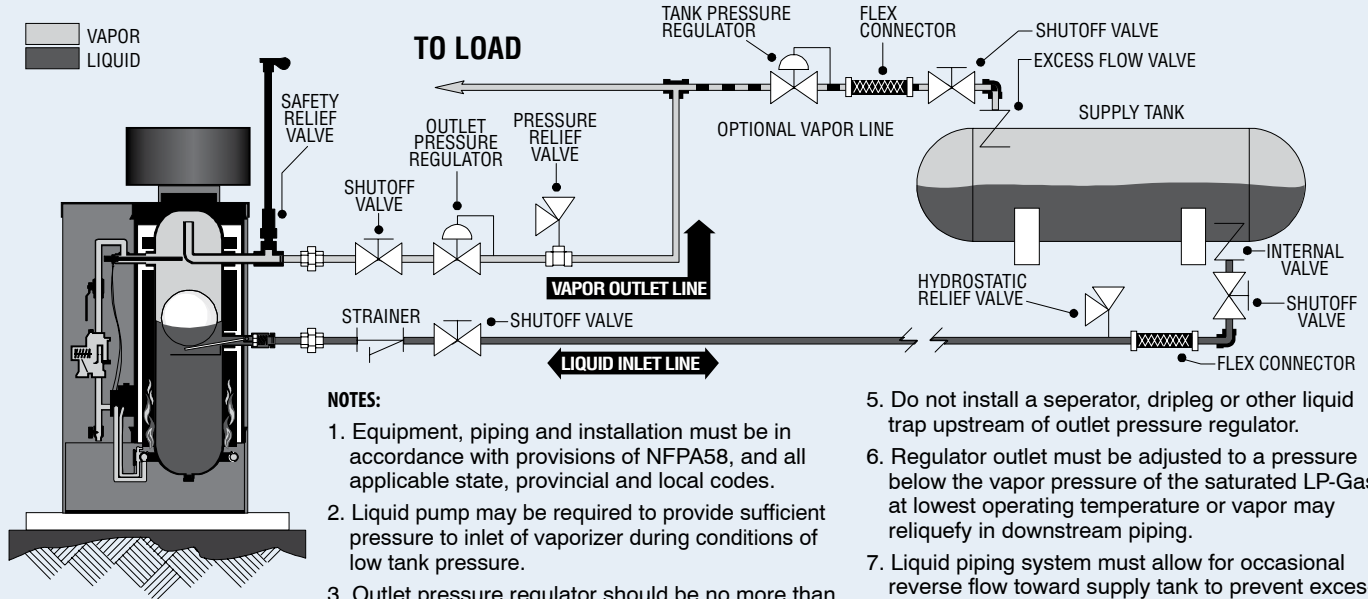

**NOTES:**

1. Equipment, piping and installation must be in accordance with provisions of NFPA58, and all applicable state, provincial and local codes.
2. Liquid pump may be required to provide sufficient pressure to inlet of vaporizer during conditions of low tank pressure.
3. Outlet pressure regulator should be no more than 24 inches from vaporizer outlet and located at or above centerline of vaporizer outlet.
4. Set tank pressure regulator 2 PSI lower than outlet pressure regulator.
5. Do not install a separator, dripleg or other liquid trap upstream of outlet pressure regulator.
6. Regulator outlet must be adjusted to a pressure below the vapor pressure of the saturated LP-Gas at lowest operating temperature or vapor may reliquefy in downstream piping.
7. Liquid piping system must allow for occasional reverse flow toward supply tank to prevent excessive pressures during operation.
8. Use proper excess flow for piping size transitions.

**Why Use a Vaporizer?**

- Pressure in the tank drops too low during cold weather.
- Storage is not big enough to supply the load under all conditions.
- Space restrictions do not allow for installations of additional tanks.
- Regulations will not allow a big enough tank or enough storage to handle the load with natural vaporization.
- Having a vaporizer eliminates recondensation of vapor to liquid in the supply lines.
- The storage tanks do not need to be kept 60-75% full during cold weather.

**Vaporizer Liquid Line Sizing**

GPH	DISTANCE - FROM STORAGE TO VAPORIZER, IN FEET					
	25'	50'	75'	100'	150'	200'
50	3/4"	3/4"	3/4"	3/4"	3/4"	3/4"
80	3/4"	3/4"	3/4"	3/4"	3/4"	3/4"
120	3/4"	3/4"	3/4"	3/4"	3/4"	3/4"
200	1"	1"	1"	1"	1"	1"
400	1"	1"	1"	1 1/4"	1 1/4"	1 1/4"
600	1"	1 1/4"	1 1/4"	1 1/4"	1 1/4"	1 1/2"
800	1 1/4"	1 1/4"	1 1/4"	1 1/4"	1 1/2"	1 1/2"
1000	1 1/4"	1 1/4"	1 1/2"	1 1/2"	1 1/2"	1 1/2"

1. Equivalent pipe lengths must be added for restrictions such as pipe fittings and valves, then added to total feet of pipe
2. Chart is based on a pressure drop of 1 PSI
3. Consult engineering for larger vaporizers or longer pipe runs

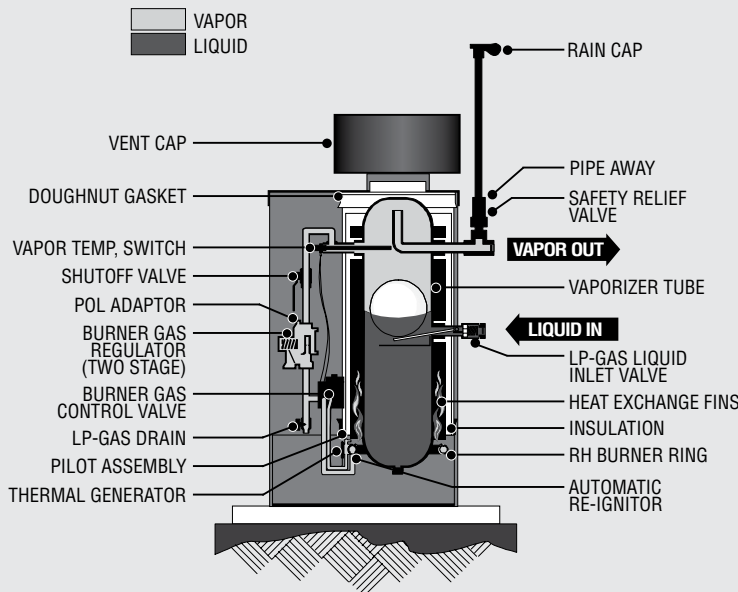



## VAPORIZER INSTALLATION

(back side)

### Quick Reference Guide For Vaporizers

Make sure you are thoroughly trained before you attempt any vaporizer installations. Improper conditions or procedures can cause accidents resulting in property damage and personal injury.

#### REGULATOR INSTALLATION GUIDELINES

##### RECOMMENDED INSTALLATION

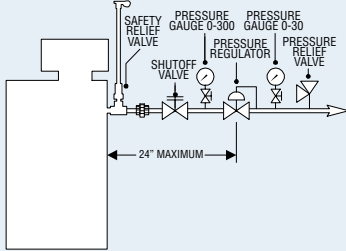

##### NOT RECOMMENDED

No isolation valve or pressure gauges.

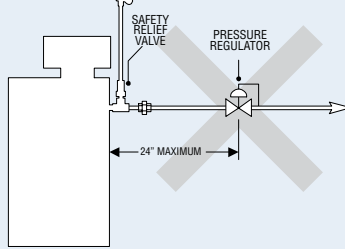

##### NOT RECOMMENDED

Regulator lower than vaporizer outlet.

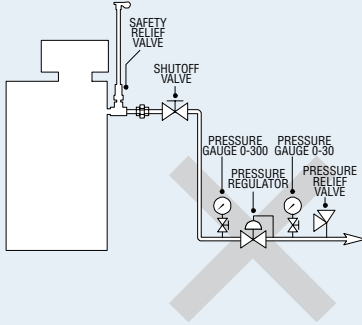

##### NOT RECOMMENDED

Regulator too far from vaporizer

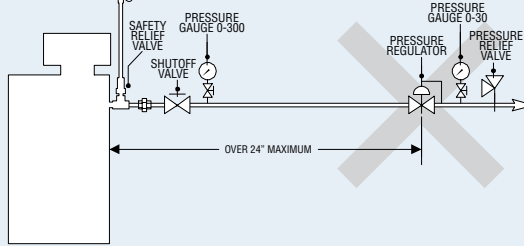

#### DRIP LEG INSTALLATION GUIDELINES

##### RECOMMENDED CONFIGURATION

Drip leg installed on low pressure side.

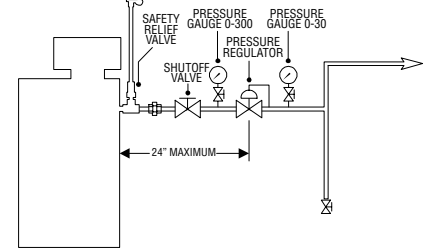

##### NOT RECOMMENDED

Not ideal configuration of drip leg.

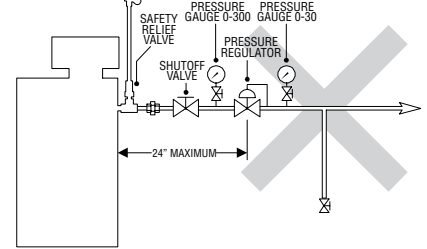

##### NOT RECOMMENDED

Vapor will recondense at no flow condition

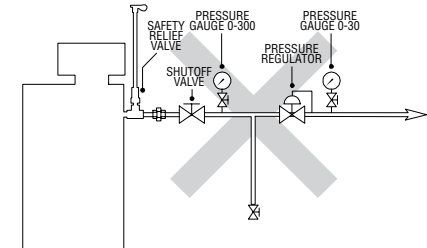

#### ONE 40/40H VAPORIZER IS EQUAL TO ...



FULL TANKS



TANKS 10% FULL

AT 40° F

FULL TANKS



TANKS 10% FULL

AT 20° F

FULL TANKS



TANKS 10% FULL

AT 0° F

FULL TANKS



TANKS 10% FULL

AT -10° F

FULL TANKS



TANKS 10% FULL

AT -20° F

**CORPORATE HEADQUARTERS**

**Tarantin Industries**  
86 Vanderveer Road  
Freehold, NJ 07728  
Toll Free: 800 922 0724  
Fx: 732 780 5173

**BRANCH LOCATIONS**

**Tarantin Industries**  
20 Commercial Drive  
Brentwood, NH 03833  
Toll Free: 800 922 0724  
Fx: 603 679 4605

**Tarantin Industries**  
30 Industrial Road  
Elizabethtown, PA 17022  
Toll Free: 800 922 0724  
Fx: 717 361 0370

**Tarantin Industries**  
9733 Coach Road  
Richmond, VA 23237  
Toll Free: 800 922 0724  
Fx: 804 279 0206

**Tarantin Industries**  
240 Oxmoor Court, Suite 268  
Birmingham, AL 35209  
Toll Free: 800 922 0724  
Fx: 877 769 1222

**Tarantin Industries**  
5050 State Road 206 West  
Elkton, FL 32033  
Toll Free: 800 922 0724  
Fx: 904 692 1068

*Servicing the East Coast  
with One Day Delivery*

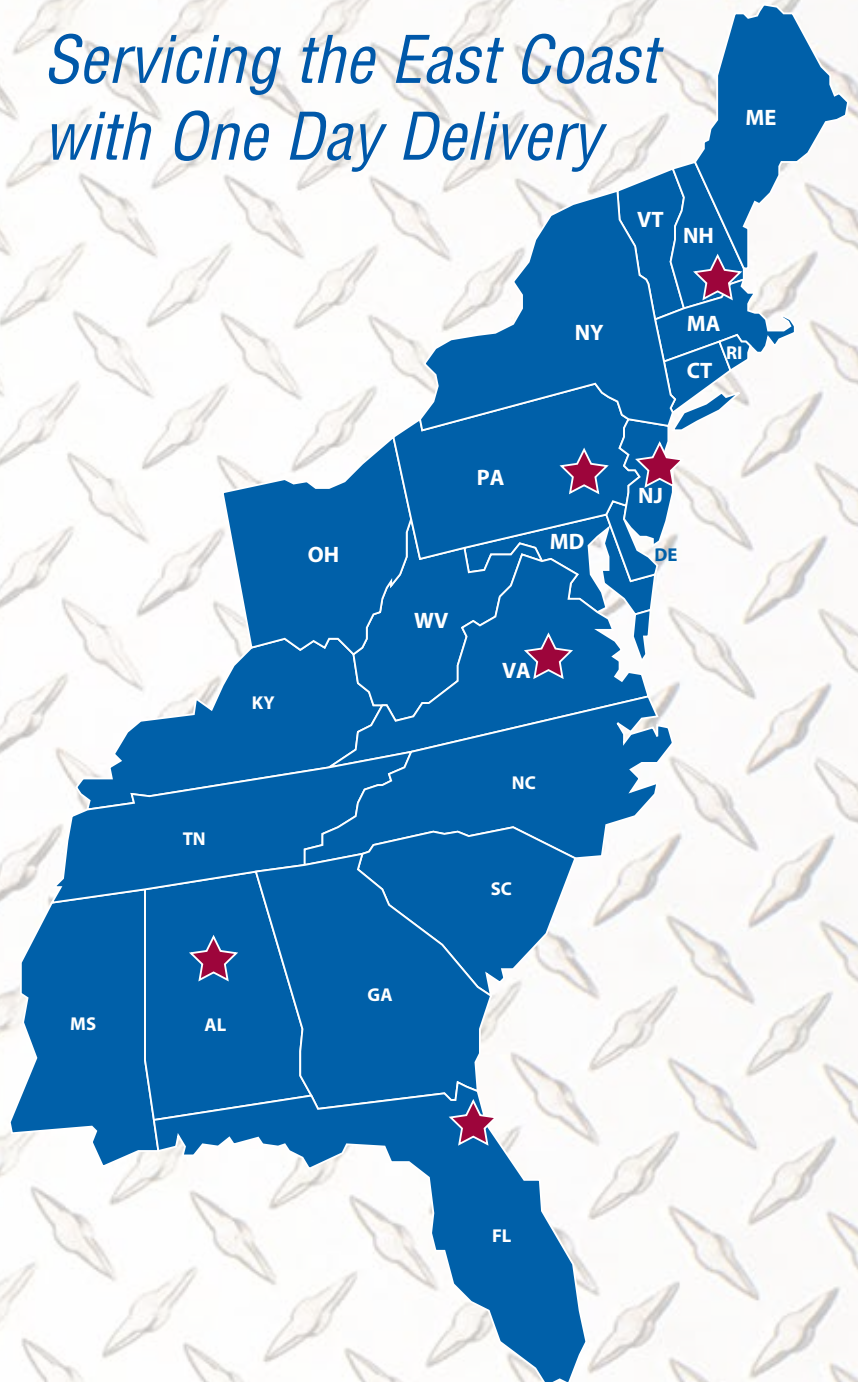

**Other Literature:**

